



SD-96 CURVED GLASS DELI CASE

UNITS MANUFACTURED PRIOR 10-1-18
 INCLUDE 1 YEAR PARTS + LABOR / 5 YEAR COMPRESSOR WARRANTY

UNITS MANUFACTURED AFTER 10-1-18
 INCLUDE 2 YEAR PARTS + LABOR / 5 YEAR COMPRESSOR WARRANTY

Dimensions

Exterior Dimensions (WxDxH)	93" x 33.5" x 47.25"
Interior Dimensions (WxDxH)	89.25"x 27" x 22"
Cubic Feet	27.6 cu.ft.
Shelf Depths:	Shelf 1: 12"
	Shelf 2: 16"
	Shelf 3: 21"
Gross Weight	888 lbs
Packaging Dimensions (WxDxH)	96.75" x 36.25" x 51"

Cooling

Temperature Range	33° - 40° F
Refrigerant	R290
Maximum Ambient Temperature Rating	90° F
Defrosting	Automatic
Temperature Display	Yes
Temperature Controller	Mechanical
H/P	3/4

Construction

Exterior Material	201 series stainless steel
Interior Material	Glass
Insulation Material	Foamed in place polyurethane
Shelf Load Capacity	44 lbs

Electrical

Voltage	110
Amps	16.5
Hz	60
Phase	1

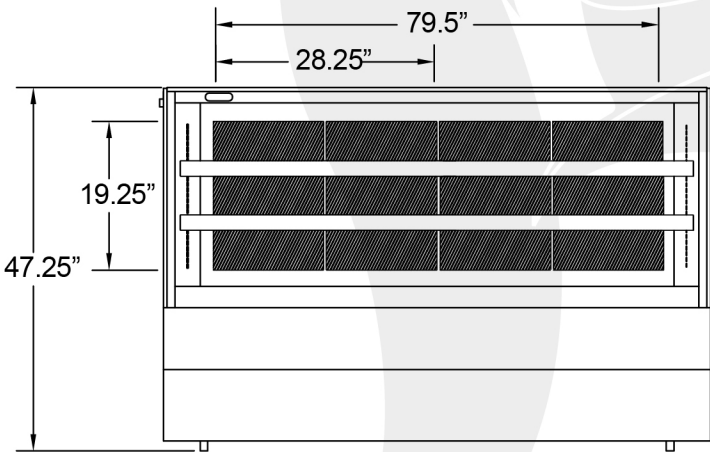

Front View

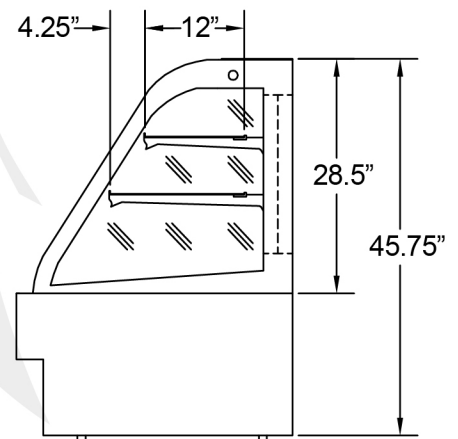

Side View

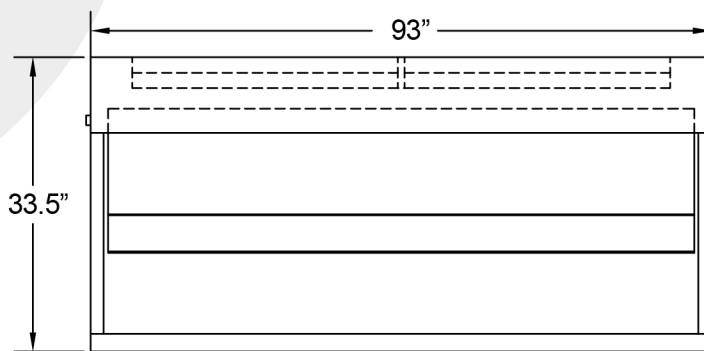

Top View

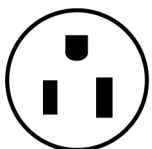

NEMA 5-15P



COMPLIES WITH ANSI/NSF 7 FOR FOOD SERVICE