



SCC-48 REFRIGERATED SHOWCASES

INCLUDE 2 YEAR PARTS + LABOR / 5 YEAR COMPRESSOR WARRANTY

Dimensions

Outside Dimensions (HxWxD)	50.5" x 47.95" x 30"
Net Weight	414.5 lbs
Gross Weight	341.7 lbs
Gross Volume (LTR)	370
40' HC Container Load (PCS)	50
Shelf Load Capacity	44 lbs
Small Shelf Dimensions (WxD)	43.39" x 12.24"
Large Shelf Dimensions (WxD)	43.39" x 14.60"

Construction

Number of Shelves	2
Adjustable Shelves	Yes
Shelf Materials	Glass
LED Control Panel	Yes
Length of Cord	70.8"
Insulation Material	C5H140
Internal LED Light	Yes
Eternal Thermometer	Yes
Lock and Key	No
Feet / Adjustable feet	4 casters, 2 w/ brakes

Cooling

Refrigerant (Type/Gram)	R290/130
Cooling Method	Ventilated
Controller	Digital
Climate Class	4
Temperature Display	Yes
Temperature Controller	Digital
Temperature Range	32°F-53.6°F

Electrical

Voltage	110
Hz	60
Watt	380
Running AMPS	4.4



Intertek

COMPLIES WITH ANSI/NSF 7 FOR FOOD SERVICE

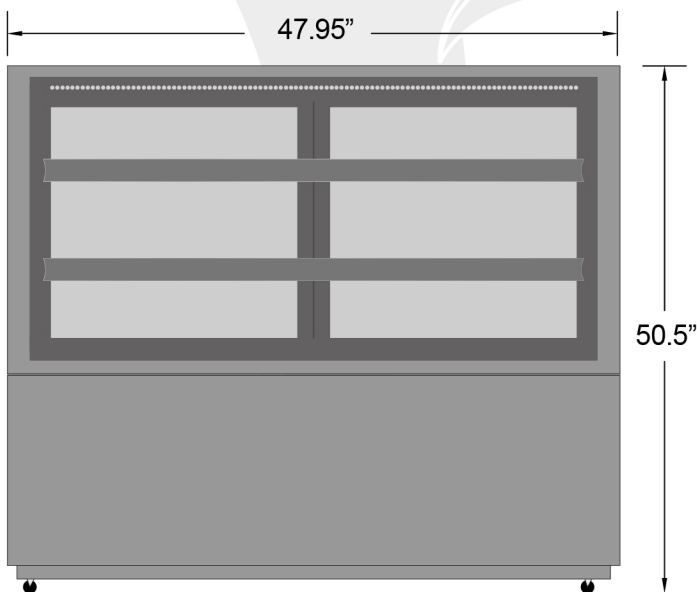

Front View

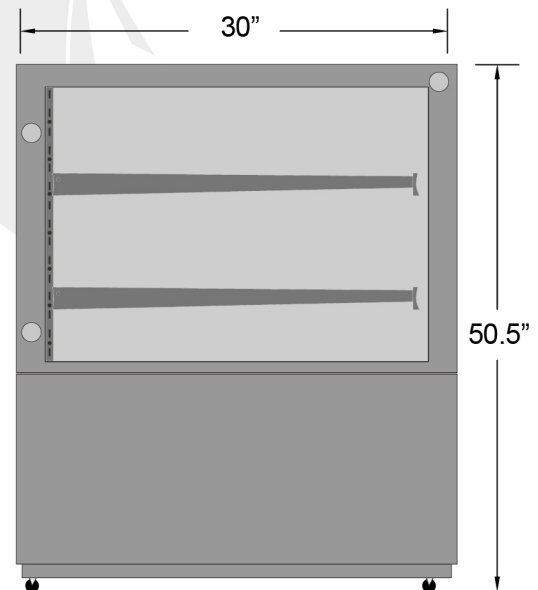

Side View