



SCB-36" CHEF BASE

UNITS MANUFACTURED PRIOR 10-1-18
INCLUDE 1 YEAR PARTS + LABOR / 5 YEAR COMPRESSOR WARRANTY

UNITS MANUFACTURED AFTER 10-1-18
INCLUDE 2 YEAR PARTS + LABOR / 5 YEAR COMPRESSOR WARRANTY

Dimensions

Exterior Dimensions (WxDxH)	36.5" x 32.25" x 25.5"
Interior Dimensions (WxDxH)	25" x 28" x 17"
Net Volume (cu. ft.)	
Gross Weight	225lbs
Packaging Dimensions (WxDxH)	40" x 35" x 29"
Electrical Cord Length	
Capacity	5.9 cu. ft.
Pans	2 - 1/1 6 - 1/6

Construction

Exterior Material	Stainless Steel
Interior Material	Stainless Steel
Insulation Material	
Shelf Material	
Shelf Load Capacity	

Cooling

Temperature Range	33° - 40° F
Refrigerant	R290
Maximum Ambient Temp	90° F
Maximum Humidity	65%
Defrosting	Automatic
Cooling System	
Temperature Display	Digital
Temperature Controller	
H/P	1/6

Electrical

Voltage	115/60/1
Amps	3.5

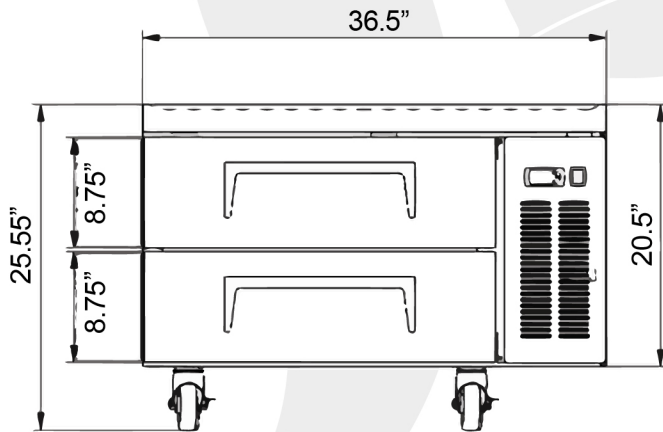

Front View

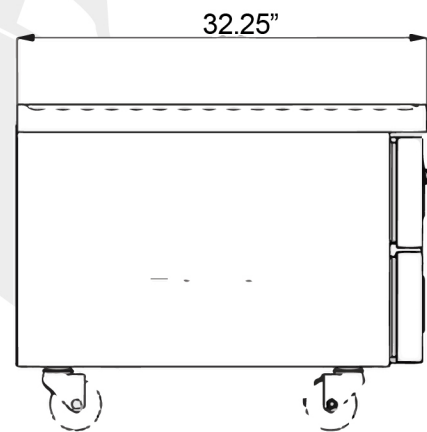

Side View

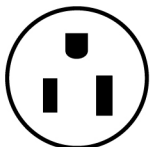

NEMA 5-15P



Intertek

COMPLIES WITH ANSI/NSF 7
FOR FOOD SERVICE