



Double Door Series Refrigerator & Freezer Bottom Mount Compressor

KBSR-3 | KBSF-3

Durable Design

- Stainless steel interior & exterior
- Coated evaporator coil
- 3 height adjustable, heavy duty, PE coated wire shelves
- LED interior lighting
- Digital temperature display
- Door lock with keys
- Simple plug-in installation
- Oversized bottom mount compressor section

Energy Efficient

- Self-closing door with stay open feature
- Seals tight with magnetic vinyl gasket
- Open door alert beeps when door has been open for 3 minutes
- Foamed-in place high-density polyurethane insulated body, CFC-free
- Large evaporator & condenser for quick cooling and greater efficiency
- Bottom mount compressor provides energy savings and ease of service

Superior Quality

- Designed for mobility, reliability & efficiency in commercial kitchens
- Certified with ETL & Energy Star guaranteeing quality standards and energy efficiency
- 4" swivel castors with 2 front brakes
- Easy grip handle
- Entirely self-contained system
- Automatic defrost system
- Digitally controlled temperature system
- Accommodates full-size bun sheet pans
- Easily adjustable shelf height
- Internal storage capacity is 18.9 cu. ft.
- NEMA 5-15 plug
- R-290 Natural Refrigerant
- Compressor : Refrigerator 1/2 HP / Freezer 1 HP Holding temperature: Refrigerator 33°F to 39°F / Freezer 5°F to -9.4°F

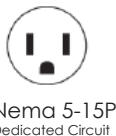

Project Name:	
Location:	
Item:	Qty:
Model:	



5659 Royalmount Ave.
 Montreal, QC, Canada H4P 2P9
 Telephone: 514.737.9701 / Toll Free: 888.275.4538
 Fax: 514.342.3854 / Toll Free: 877.453.8832
 sales@mvpgroupcorp.com / mvpgroupcorp.com

12000 Biscayne Blvd., Suite # 108
 Miami, FL, United States 33181
 Telephone: 786.600.4687 / Toll Free: 844.218.8477
 Fax: 786.661.4100



Double Door Series Refrigerator & Freezer Bottom Mount Compressor

KBSR-3 | KBSF-3

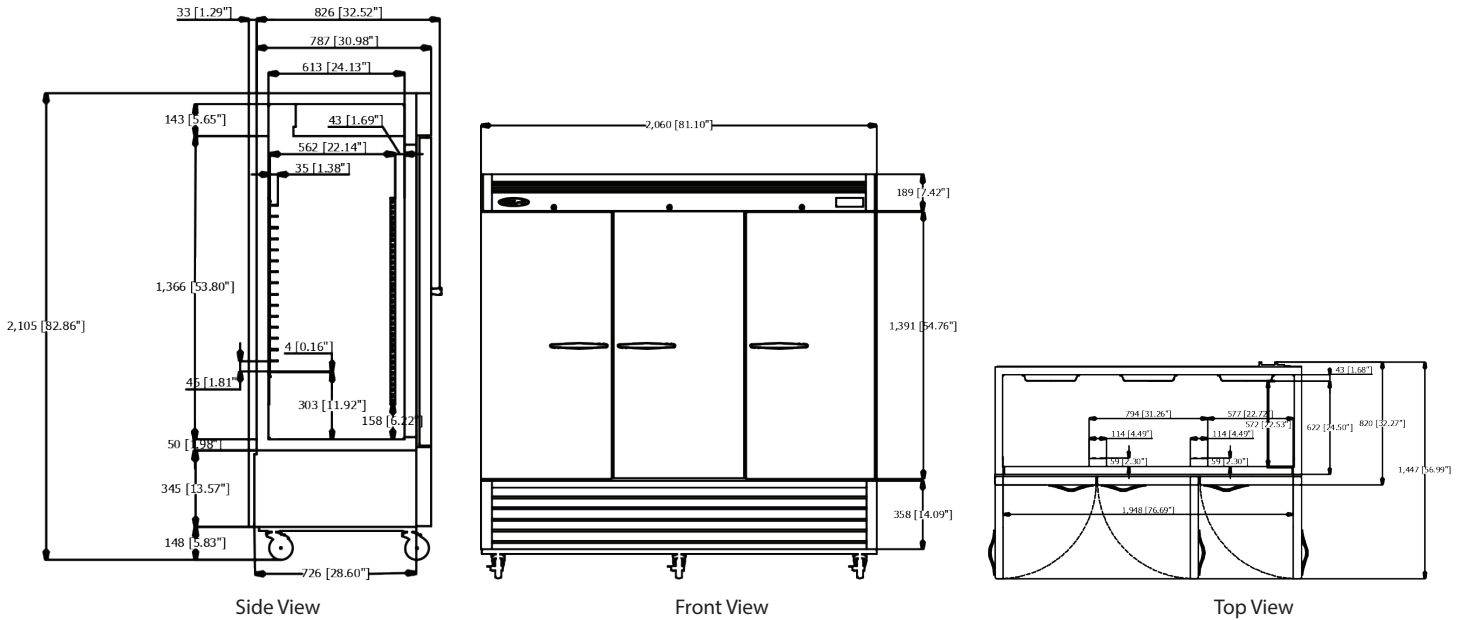

Model Number	Description	# of Shelves	Capacity (cubic ft)	External Dimensions w/handle (W x D x H in)	Internal Dimensions (W x D x H in)	Compressor Size	Voltage / Frequency	Amps	Working Temp	Refrigerant	Ship Weight (lbs)
KBSR-3	Bottom Mount Double Door Refrigerator	9	66.7	81 x 32.75 x 82.7	77.2 x 24.5 x 53.8	1/2	115V 60 HZ	6.3	33°F to 39°F	R-290	640
KBSF-3	Bottom Mount Double Door Freezer	6	66.0	81 x 32.75 x 82.7	77.2 x 24.5 x 53.8	1	115V 60 HZ	9.9	5°F to -9°F	R-290	656



These units are designed for maximum performance in an air-conditioned area of 75°F ambient temperature and 55% relative humidity. There must be adequate ventilation at the top, sides & rear of the unit for proper operation.

Warranty: 36 months parts and labor.
Additional 24 months on compressor (part only)

KOOL-IT is a registered trademark of MVP Group.
Specifications subject to change without notice.



5659 Royalmount Ave.
Montreal, QC, Canada H4P 2P9
Telephone: 514.737.9701 / Toll Free: 888.275.4538
Fax: 514.342.3854 / Toll Free: 877.453.8832
sales@mvpgroupcorp.com / mvpgroupcorp.com

12000 Biscayne Blvd., Suite # 108
Miami, FL, United States 33181
Telephone: 786.600.4687 / Toll Free: 844.218.8477
Fax: 786.661.4100