



Inferno Blaze Premium Liquid Propane 40 lb. Floor Fryer – 90,000 BTU SKU: IBP-GF-40-LP

- ★ **BTU's:** 90,000
- ★ **Burner BTU:** 30,000
- ★ **Number of Burners:** 3
- ★ **Oil Capacity (lbs):** 40
- ★ **Power Type:** Liquid Propane (LPG)
- ★ **Temperature Range:** 200°F to 400°F
- ★ **Exterior material:** Stainless steel



Introducing the Inferno Blaze Premium IBP-GF-40-LG Liquid Propane 40 lb. Floor Fryer – a powerhouse of culinary excellence designed to elevate your cooking game! With an impressive 90,000 BTU, this fryer means business when it comes to delivering the perfect crispy texture to your favorite dishes.

BTU's	90,000
Burner BTU	30,000
Casters Size (Inch)	6
Certifications	ETL Listed, ETL Sanitation
Color	Silver
Cord Length (ft)	9.5
Exterior material	Stainless steel
Gas Inlet Size (inch)	3/4" NPT
Number of Baskets	2
Number of Burners	3
Oil Capacity (lbs)	40
Power Type	LPG
Shipping Weight (lbs)	160
Temperature Range	200°F to 400°F
Weight (lbs)	135

Crafted with a robust stainless steel exterior, this fryer not only looks sleek in its silver finish but also promises durability that can withstand the rigors of a busy kitchen. The 3/4" NPT gas inlet size ensures a steady and efficient gas supply for uninterrupted cooking.

Equipped with three burners, each packing 30,000 BTU, and a spacious 40 lb. oil capacity, you can easily multitask and prepare a variety of delectable treats. The temperature range of 200°F to 400°F gives you precise control over your cooking, ensuring every dish turns out perfectly.

Featuring two baskets, you can fry up a storm and meet the demands of a hungry crowd. The convenient 6-inch casters make it easy to maneuver this fryer around your kitchen space, allowing for flexibility and ease of use.

Safety and quality are paramount, and this fryer comes with ETL Listed and ETL Sanitation certifications, giving you peace of mind in your kitchen. With a shipping weight of 160 lbs and a unit weight of 135 lbs, you can trust in the sturdiness of this appliance.

Item	Item Depth (inch)	Item Height (inch)	Item Width (inch)
Exterior	30.1	37.9	15.6

Certified Quality

ETL-certified, the Inferno Blaze guarantees quality and adheres to rigorous safety standards, offering peace of mind.



Kitchen Pro Restaurant Equipment: info@gokpe.com | www.kitchenproequipment.com | T. 1(800)603-0033

Note: Specifications subject to change without notice.

Not recommended for use in non-commercial or residential settings.

Technical Data:

FRONT VIEW

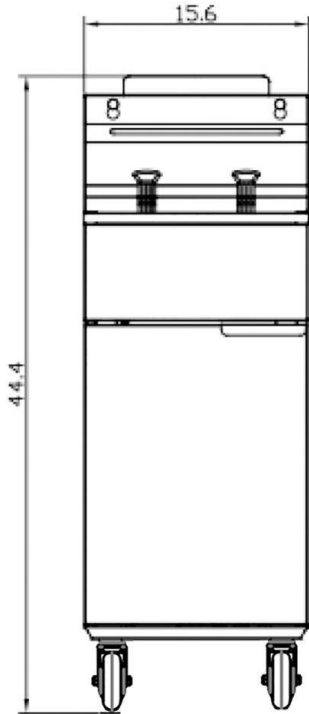

SIDE VIEW

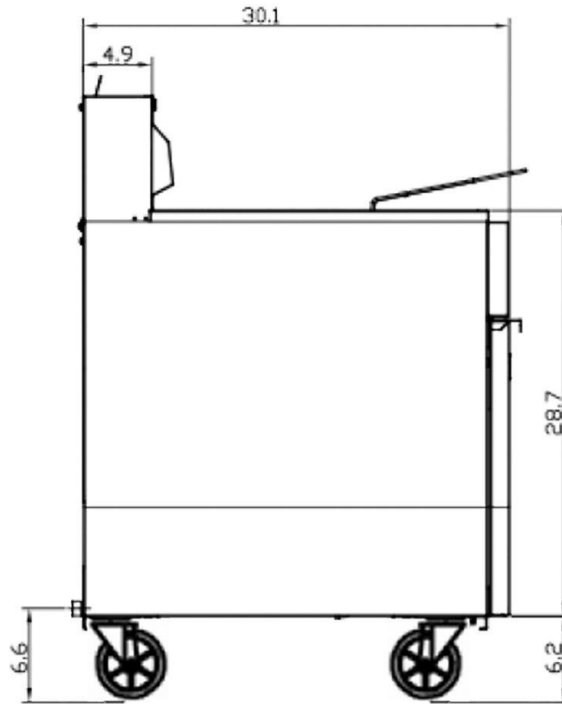

TOP VIEW

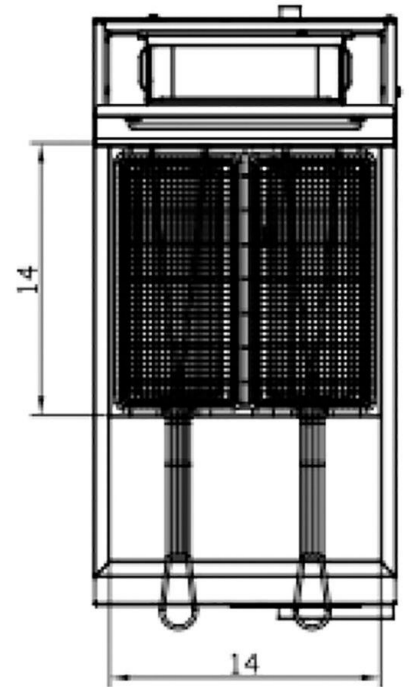

Whether you're running a bustling restaurant or simply love indulging in homemade fried delights, the Inferno Blaze Premium Liquid Propane Floor Fryer is your go-to kitchen companion. Elevate your culinary creations and experience the power of 90,000 BTU at your fingertips. Don't miss out on the opportunity to take your frying skills to the next level with this exceptional appliance.

Warning: This product can expose you to chemicals including lead, which are known to the State of California to cause cancer, birth defects, or other reproductive harm. For more information, go to www.p65warnings.ca.gov.