

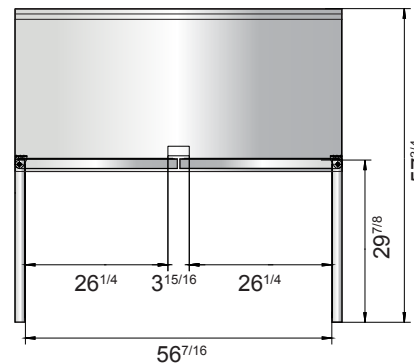

## SPECIFICATIONS

Models	Door	Capacity (Cu.Ft.)	Shelves	Casters (inch)	Amps (A)	Voltage (V/Hz/Ph)	HP	Refrigerant	Exterior Dimensions (inch)	Net Weight (lb)	Gross Weight (lb)
FGA-WTR-1D-28	1	7.2	1	4	2.3	115/60/1	1/7	R290	27 <sup>1/2</sup> ×30×39 <sup>4/5</sup>	137	176
FGA-WTR-2D-48	2	13.4	2	4	2.3	115/60/1	1/7	R290	48 <sup>3/10</sup> ×30×39 <sup>4/5</sup>	192	242
FGA-WTR-2D-60	2	17.2	2	4	2.8	115/60/1	1/5	R290	60 <sup>1/5</sup> ×30×39 <sup>4/5</sup>	218	277

## PLAN VIEW

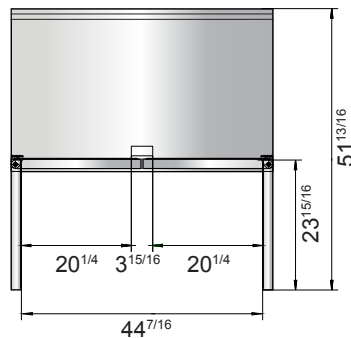
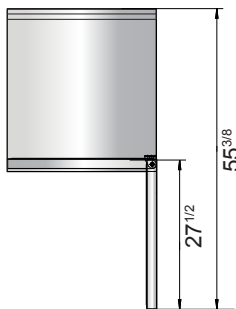
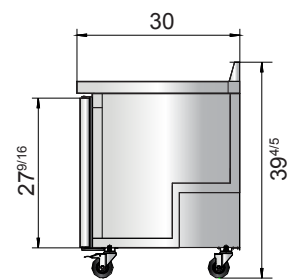
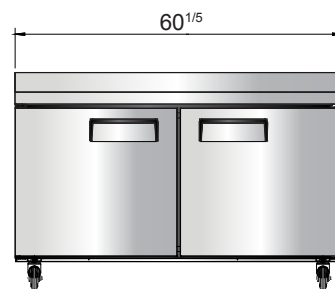
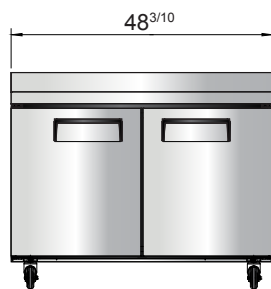
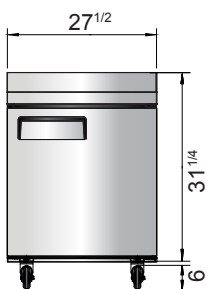

FGA-WTR-1D-28

FGA-WTR-2D-48

FGA-WTR-2D-60

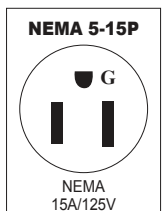

REV. 09/24