



SPECIFICATIONS

| Models | Door | Capacity (Cu.Ft.) | Shelves | Casters (inch) | Rated Current (A) | Voltage (V/Hz/Ph) | HP | Refrigerant | Exterior Dimensions (inch) | Net Weight (lb) | Gross Weight (lb) |
|-----------------|------|-------------------|---------|----------------|-------------------|-------------------|-----|-------------|--|-----------------|-------------------|
| FGA-MGDR-2SD-54 | 2 | 44.9 | 8 | 2 | 4.2 | 115/60/1 | 1/4 | R290 | 54 ^{2/5} ×29 ^{7/10} ×81 ^{1/5} | 456 | 511 |
| FGA-MGDR-3SD-88 | 3 | 64.4 | 12 | 2 | 6.5 | 115/60/1 | 1/2 | R290 | 81 ^{7/8} ×29 ^{3/4} ×81 ^{3/8} | 547 | 705 |

PLAN VIEW

FGA-MGDR-2SD-54

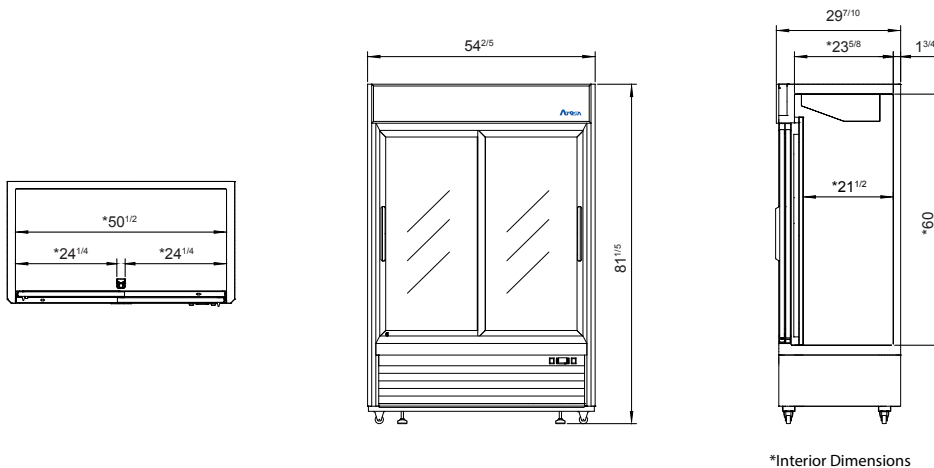

*Interior Dimensions

FGA-MGDR-3SD-88

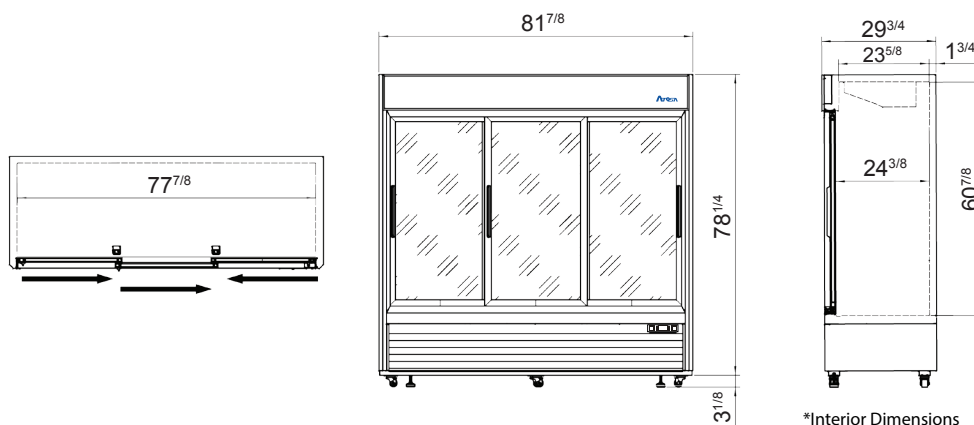

*Interior Dimensions

