

FRIGOS



Frigos Premium 2-Door
Undercounter Freezer
SKU: FGP-UCFZ-48

- ★ 12 cu. ft. interior space
- ★ Equipped with 2 shelf and reliable 1/3 HP compressor
- ★ Stainless steel exterior and interior
- ★ Durable door with rounded corners and recessed handle
- ★ 6" casters for easy mobility
- ★ Digital controller provides temperature readouts
- ★ Temperature holding range: -7°F to 3°F
- ★ Eco-friendly R290 refrigerant, 4.1 KW/24hr consumption



Amps	6.5
Capacity (Cu Ft)	12
Caster Size (Inch)	6
Color	Silver
Compressor Location	Back Mounted
Door Style	Swing
Door Type	Solid
Horsepower (HP)	1/3
KW per 24h	4.1
Number of Doors	2
Number of Shelves	2
Plug Type	Nema 5-15P
Refrigerant	R-290
Shipping Weight (lbs)	242
Temperature Range	-7° F - 3° F
Voltage	115/60/1
Weight (lbs)	233

Introducing the Frigos Premium FGP-UCFZ-48, a robust 2-Door Undercounter Freezer with a 12 cubic feet capacity, tailored to meet the precise needs of your commercial kitchen. This freezer is designed to not only maximize your storage space but also keep your frozen goods in pristine condition.

With a back-mounted compressor, two solid swing doors, and two shelves, the FGP-UCFZ-48 ensures easy access and efficient organization of your frozen items. It boasts an impressive temperature range of -7° F to 3° F, guaranteeing that your products remain consistently frozen. The unit is not only powerful but also energy-efficient, equipped with a 1/3 HP compressor and eco-friendly R290 refrigerant, consuming just 4.1 KW per 24 hours and reducing operational costs.

With its sleek silver exterior, 6-inch caster wheels for easy mobility, and stainless steel interior and exterior, this undercounter freezer combines style and durability. Whether you're operating a bustling restaurant, a catering business, or any other food establishment, the Frigos Premium FGP-UCFZ-48 is your ideal choice for preserving the quality and accessibility of your frozen goods, ensuring that your kitchen functions at its best.

Item	Width (Inch)	Depth (Inch)	Height (Inch)	Material
Exterior	48.2	30	37.25	Stainless steel
Interior	44.7	23.6	26.7	Stainless steel



Kitchen Pro Restaurant Equipment: info@gokpe.com | www.kitchenproequipment.com | T. 1(800)603-0033

Note: Specifications subject to change without notice.

Plan View

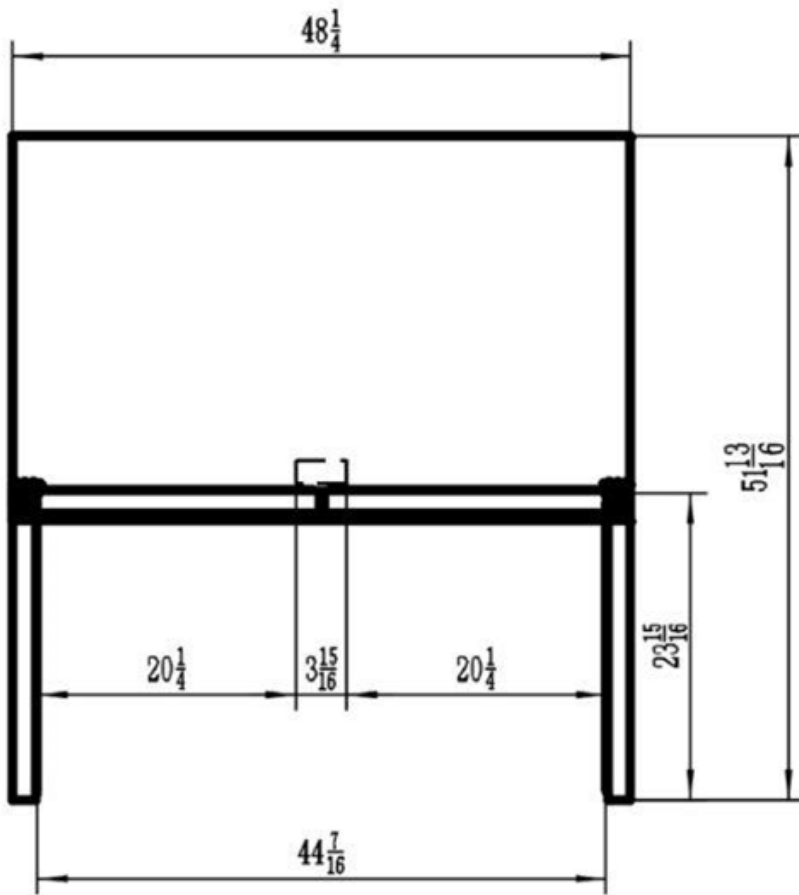
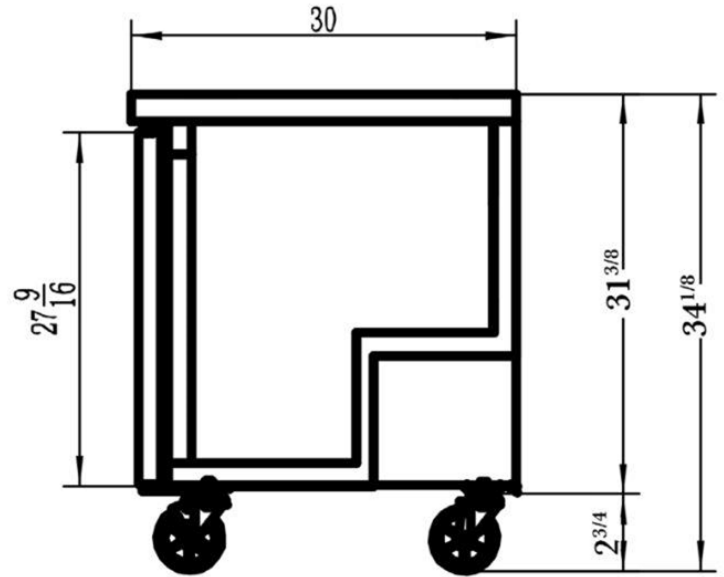
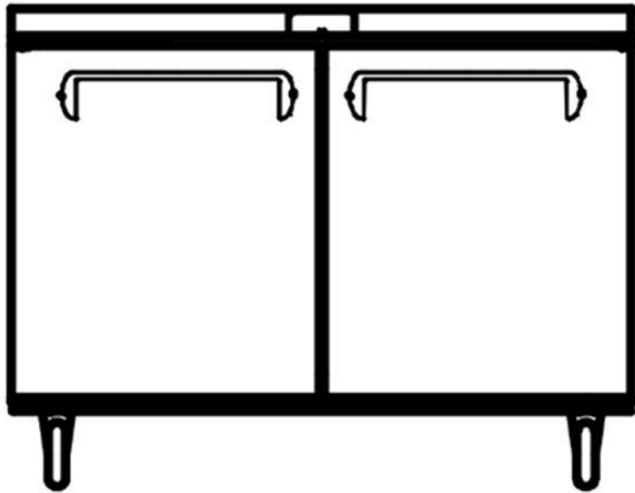

Frigos Premium FGP-UCFZ-48 stands as a testament to innovation and excellence in the realm of commercial kitchen appliances. Its robust design, efficient performance, and thoughtful features make it the perfect companion for any culinary endeavor.

Warning: This product can expose you to chemicals including lead, which are known to the State of California to cause cancer, birth defects, or other reproductive harm. For more information, go to www.p65warnings.ca.gov.