

FRIGOS



Frigos Premium Two Swing Glass Door Merchandiser Refrigerator
SKU: FGP-RFM-49

- ★ 49 cu. ft. interior space
- ★ 8 shelves for organized product display
- ★ LED interior lighting
- ★ Recessed door handles for convenience and safety
- ★ Illuminated panel above the doors
- ★ Temperature holding range: 33°F to 41°F
- ★ Digital temperature controller for precise management
- ★ Uses eco-friendly R290 hydrocarbon refrigerant



Amps	7
Capacity (Cu Ft)	49
Caster Size (Inch)	3
Color	White
Compressor Location	Bottom Mounted
Door Style	Swing
Door Type	Glass
Horsepower (HP)	1/4+
Number of Doors	2
Number of Shelves	8
Plug Type	Nema 5-15P
Refrigerant	R-290
Shipping Weight (lbs)	471
Temperature Range	33°F to 41°F
Voltage	115/60/1
Weight (lbs)	445

Elevate your business with the Frigos Premium FGP-RFM-49 Two Swing Glass Door Merchandiser Refrigerator, a 49 cubic feet capacity refrigerator designed to showcase your products in style. This refrigerator offers exceptional versatility and a temperature range of 33°F to 41°F, ensuring your items remain fresh and enticing to customers.

With two swing glass doors and eight adjustable shelves, this refrigerator provides ample space for your merchandise while allowing for a customizable arrangement. Its 1/4+ HP bottom-mounted compressor efficiently maintains the desired temperature, and it's easy to access for maintenance.

Crafted with a white powder-coated steel exterior and a stainless steel/white powder-coated steel interior, this refrigerator is not only sturdy but also visually appealing. The Nema 5-15P plug type simplifies the setup process, making this Frigos Premium merchandiser refrigerator a valuable addition to supermarkets, convenience stores, and more. Enhance your product display and keep your items at their best with the FGP-RFM-49.

Item	Width (Inch)	Depth (Inch)	Height (Inch)	Material
Exterior	54.4	31.5	81	White powder coated steel
Interior	49.7	25.1	60	White powder coated steel/Stainless steel



Kitchen Pro Restaurant Equipment: info@gokpe.com | www.kitchenproequipment.com | T. 1(800)603-0033

Note: Specifications subject to change without notice.

Plan View

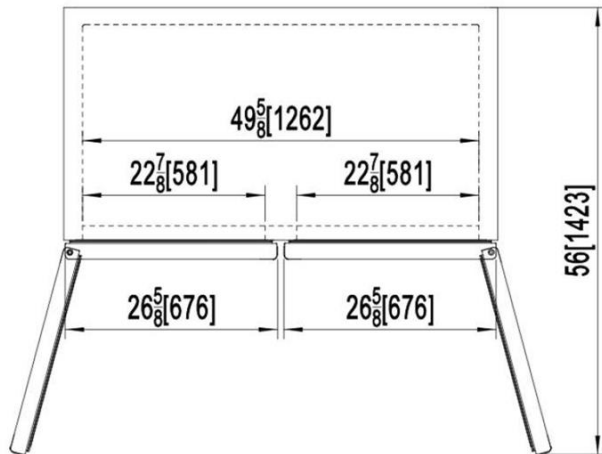
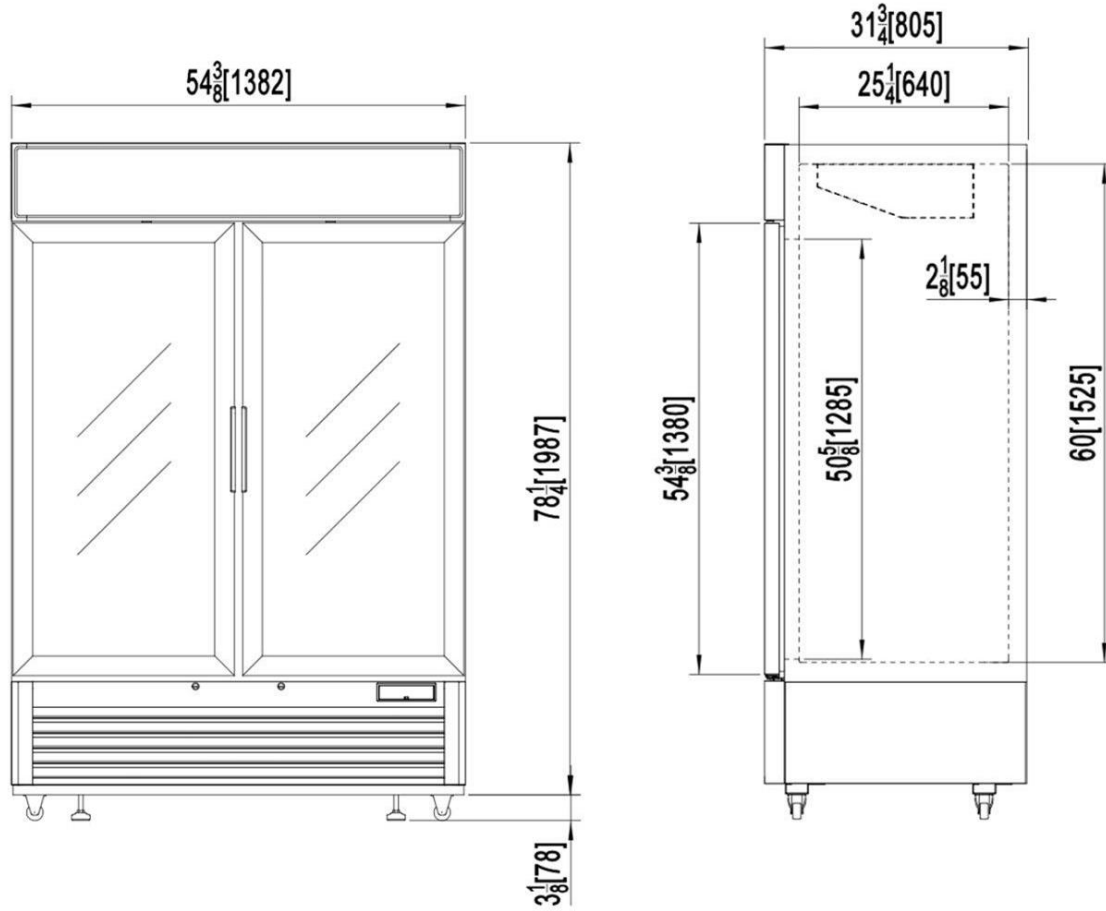

Elevate your business display with the Frigos Premium FGP-RFM-49. Two swing glass doors, eight adjustable shelves, and a 49 cubic feet capacity ensure freshness and style. Simplify setup with the Nema 5-15P plug type, making this refrigerator a valuable addition to supermarkets and convenience stores.

Warning: This product can expose you to chemicals including lead, which are known to the State of California to cause cancer, birth defects, or other reproductive harm. For more information, go to www.p65warnings.ca.gov.