

FRIGOS



Frigos Premium One Solid Door
Reach-In Refrigerator
SKU: FGP-RF-1DLH

- ★ 23 cu. ft. interior space
- ★ Equipped with 3 shelves and 1/7+ HP compressor
- ★ Stainless steel exterior and interior
- ★ Durable door with recessed handle
- ★ 4" casters for easy mobility
- ★ Digital controller provides temperature readouts
- ★ Temperature holding range: 33°F to 41°F
- ★ Eco-friendly R290 refrigerant, 1.56 KW/24hr consumption



Amps	3.5
Capacity (Cu Ft)	23
Caster Size (Inch)	4
Color	Silver
Compressor Location	Top Mounted
Door Style	Swing
Door Type	Solid
Horsepower (HP)	1/7+
KW per 24h	1.56
Number of Doors	1
Number of Shelves	3
Plug Type	Nema 5-15P
Refrigerant	R-290
Shipping Weight (lbs)	284
Temperature Range	33°F to 41°F
Voltage	115/60/1
Weight (lbs)	264

Introducing the Frigos Premium FGP-RF-1DLH, a dependable 28" One Solid Door Reach-In Refrigerator designed for the rigorous demands of commercial kitchens. Boasting a generous 23 cubic feet capacity, this refrigerator is ideal for keeping your ingredients and perishable goods fresh and organized.

The FGP-RF-1DLH features a top-mounted compressor, a solid swing door, and three shelves, ensuring easy access and optimal storage space for your products. It consistently maintains a temperature range of 33°F to 41°F, guaranteeing your items are stored in the best conditions. With a 1/7+ HP compressor and eco-friendly R290 refrigerant, this refrigerator is engineered for energy efficiency, consuming a mere 1.56 KW per 24 hours, which can lead to substantial cost savings for your business.

This refrigerator comes in a sleek silver exterior, equipped with four-inch caster wheels for effortless mobility, and features a robust stainless steel interior and exterior for both style and durability. Whether you're running a bustling restaurant, a bakery, or any food service establishment, the Frigos Premium FGP-RF-1DLH is your reliable choice for efficient refrigeration, ensuring your kitchen operates at peak performance.

Item	Width (Inch)	Depth (Inch)	Height (Inch)	Material
Exterior	28.7	33.2	83.8	Stainless steel
Interior	24	26.5	60.2	Stainless steel



Kitchen Pro Restaurant Equipment: info@gokpe.com | www.kitchenproequipment.com | T. 1(800)603-0033

Note: Specifications subject to change without notice.

Plan View

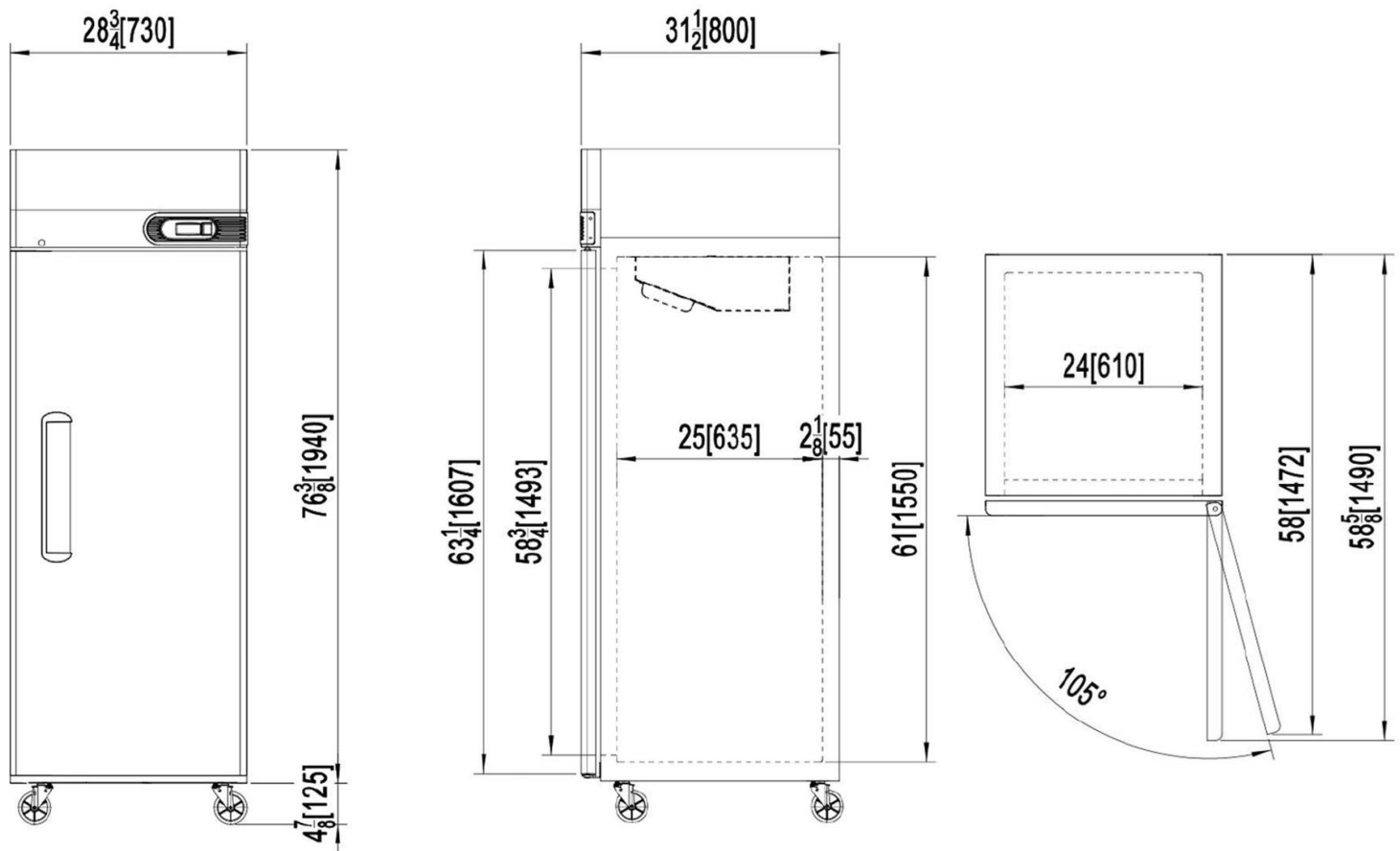

Elevate your commercial kitchen experience with the Frigos Premium FGP-RF-1DLH – where reliability meets efficiency. Invest in the assurance of optimal storage conditions and seamless organization for your perishable goods, backed by the stylish design and durable construction that defines Frigos Premium refrigeration solutions.

Warning: This product can expose you to chemicals including lead, which are known to the State of California to cause cancer, birth defects, or other reproductive harm. For more information, go to www.p65warnings.ca.gov.