



## Frigos Platinum 3 Door 72" Sandwich Prep Table SKU: FG-SWPTS-72

- ★ Spacious: 22.3 cu ft capacity
- ★ Durable: Stainless steel exterior and interior
- ★ Efficient: Low energy usage (6.49 kWh/24h)
- ★ Convenient: Self-closing doors, efficient LED lighting
- ★ Certified: ETL Electrical, ETL Sanitation, DOE
- ★ Mobility: Locking casters
- ★ Powerful: 1/5 HP compressor



<b>Refrigerant</b>	R290
<b>Horsepower (HP)</b>	1/5
<b>Voltage (V)</b>	115V/60hz
<b>KW per 24h</b>	6.49kw.h/24h
<b>Wattage</b>	460
<b>Shipping Weight (lbs)</b>	200
<b>Door Self Closed</b>	Yes
<b>Interior Material</b>	Stainless Steel
<b>Exterior Material</b>	Stainless Steel
<b>Color</b>	Silver
<b>Door Style</b>	Swing
<b>Door Type</b>	Solid
<b>Number of Doors</b>	3
<b>Compressor Location</b>	Rear Mounted
<b>Shelf Capacity (lbs)</b>	85
<b>Plug Type</b>	NEMA 5-15P

Introducing our flagship 72" sandwich prep table, the Frigos Platinum FG-SWPTS-72, meticulously engineered to meet the rigorous demands of your commercial kitchen. With precise dimensions of 72 inches in width, 30 3/8 inches in depth, and 45 3/8 inches in height, this unit offers an expansive workspace for all your food preparation needs.

Crafted with a robust stainless steel exterior and interior, this prep table combines durability with impeccable hygiene standards. Boasting an impressive 22.3 cubic feet of storage capacity, complete with eighteen included pans, it's perfectly suited for sandwich and salad preparation.

Item	Width (Inch)	Depth (Inch)	Height (Inch)
<b>Exterior</b>	72	30 3/8	45 3/8
<b>Interior</b>	67 3/4	25 3/8	28 3/4

Capacity (Cu Ft)	Number of Shelves
22.3	3

- **Crafted:** Sturdy stainless steel exterior, clean stainless steel interior, and a dependable 304 stainless steel floor.
- **Storage:** Ample with epoxy-coated shelf, supports up to 85 pounds.
- **Insulation:** Superior with substantial 2-inch insulation for precise temperature control.
- **Performance:** High-powered by a 1/5 HP compressor, ensuring top-tier reliability and efficiency.



**Kitchen Pro Restaurant Equipment:** [info@gokpe.com](mailto:info@gokpe.com) | [www.kitchenproequipment.com](http://www.kitchenproequipment.com) | T. 1-800-603-0033

Note: Specifications subject to change without notice.

The Frigos Platinum FG-SWPTS-72 is engineered for energy efficiency, featuring a 1/5 HP compressor operating at 115V/60Hz and utilizing environmentally friendly R290 refrigerant. It's designed to minimize energy consumption, with operating costs as low as 6.49 kW.h/24h, ensuring long-term savings for your business.

This unit's three solid doors, all reversible for convenience and energy efficiency, maintain a secure seal to preserve the freshness of your ingredients. Inside, you'll find three robust shelves, each with a remarkable 85-pound capacity. Integrated LED lighting guarantees optimal visibility during food preparation.

Hinge Location	Amps (A)	Hertz (Hz)	Temperature Range
left/right/right	5.2A	60Hz	33°F to 40°F
Phase	Shelves Size	Shelf Capacity (lbs)	Caster Size (inch)
1	20.8 x 19	85	5

Elevate your commercial kitchen with the Frigos Platinum FG -SWPTS-72 sandwich prep table. Whether you're in the foodservice industry or managing a restaurant, this prep table ensures your ingredients remain fresh and at the right temperature, preserving their quality.

### 3 Door 72" Sandwich Prep Table Prep Table | FG-SWPTS-72

Certified by ETL Electrical, ETL Sanitation, and DOE, the FG-SWPT-72 adheres to essential health and safety standards. Its sleek silver finish and swing-style solid doors not only convey a professional appearance but also provide effortless access to your ingredients.



Invest in the future of your business with the Frigos Platinum FG-SWPTS-72. It's a powerful, energy-efficient, and reliable addition to any kitchen, designed to meet your needs for years to come. Explore our range of prep tables and kitchen equipment to optimize your operations. Choose Frigos Platinum for quality and performance.

## Technical Data:

### FRONT VIEW

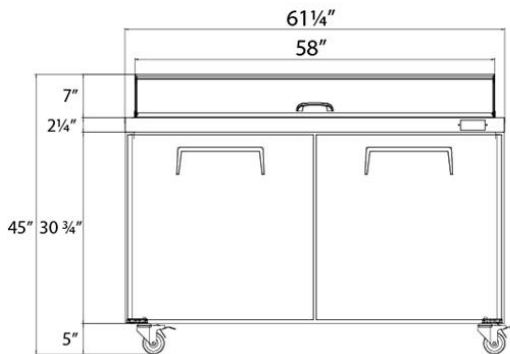

### TOP VIEW

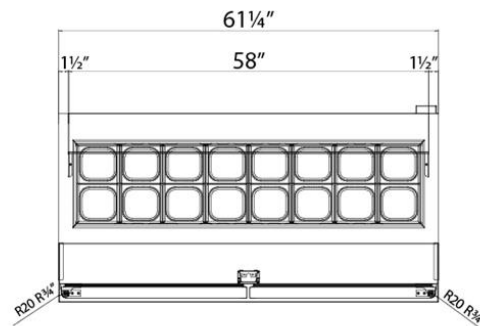

### TOP VIEW

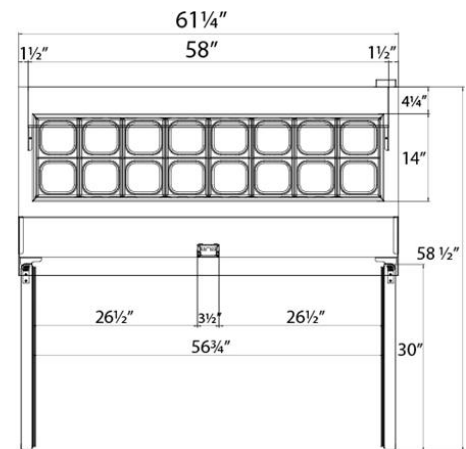

## 2 Door 60" Sandwich Prep Table Table | SKU: **FG-SWPTS-60**

The self-closing door adds convenience and saves energy by ensuring a proper seal at all times. Moving it around is effortless with four 5-inch casters that provide stability and mobility.



**Warning:** This product can expose you to chemicals including lead, which are known to the State of California to cause cancer, birth defects, or other reproductive harm. For more information, go to [www.p65warnings.ca.gov](http://www.p65warnings.ca.gov).