

FRIGOS

PLATINUM REFRIGERATION EQUIPMENT



Frigos Platinum 2 Door 60" Sandwich Prep Table SKU: FG-SWPTS-60

- ★ Spacious: 17.8 cu ft capacity
- ★ Durable: Stainless steel exterior and interior
- ★ Efficient: Low energy usage (4.59 kWh/24h)
- ★ Convenient: Self-closing doors, efficient LED lighting
- ★ Certified: ETL Electrical, ETL Sanitation, DOE
- ★ Mobility: Locking casters
- ★ Powerful: 1/5 HP compressor



Refrigerant	R290
Horsepower (HP)	1/5
Voltage (V)	115V/60hz
KW per 24h	4.59kw.h/24h
Wattage	443
Shipping Weight (lbs)	138
Door Self Closed	Yes
Interior Material	Stainless Steel
Exterior Material	Stainless Steel
Color	Silver
Door Style	Swing
Door Type	Solid
Number of Doors	2
Compressor Location	Rear Mounted
Shelf Capacity (lbs)	85
Plug Type	NEMA 5-15P

Introducing our premium 60" sandwich prep table, the Frigos FG-SWPTS-60, meticulously designed to meet the demands of your commercial kitchen. With precise dimensions of 60 inches in width, 30 3/8 inches in depth, and 45 3/8 inches in height, this unit offers generous space for all your food preparation needs.

Crafted with a robust stainless steel exterior and a clean, easy-to-maintain stainless steel interior, this prep table ensures both durability and hygiene. The impressive 17.8 cubic feet of storage capacity, coupled with sixteen included pans, make it ideal for sandwich and salad preparation.

Item	Width (Inch)	Depth (Inch)	Height (Inch)
Exterior	60	30 3/8	45 3/8
Interior	57	25 3/8	28 3/4

Capacity (Cu Ft)	Number of Shelves
17.8	2

- **Crafted:** Sturdy stainless steel exterior, clean stainless steel interior, and a dependable 304 stainless steel floor.
- **Storage:** Ample with epoxy-coated shelf, supports up to 85 pounds.
- **Insulation:** Superior with substantial 2-inch insulation for precise temperature control.
- **Performance:** High-powered by a 1/5 HP compressor, ensuring top-tier reliability and efficiency.



Kitchen Pro Restaurant Equipment: info@gokpe.com | www.kitchenproequipment.com | T. 1-800-603-0033

Note: Specifications subject to change without notice.

The Frigos FG-SWPTS-60 features energy-efficient components, including a 1/5 HP compressor operating at 115V/60Hz and utilizing eco-friendly R290 refrigerant. It consumes minimal energy, costing only 4.59 kW.h/24h, ensuring cost savings for your business.

This unit's two solid doors are reversible for convenience and energy efficiency, providing an effective seal to keep your ingredients fresh. Inside, you'll find two sturdy shelves, each capable of holding up to 85 pounds. LED lighting is integrated for clear visibility during food preparation.

Hinge Location	Amps (A)	Hertz (Hz)	Temperature Range
left/right	3.5A	60Hz	33°F to 40°F
Phase	Shelves Size	Shelf Capacity (lbs)	Caster Size (inch)
1	27.2 x 19	85	5

Elevate your commercial kitchen with the Frigos Platinum FG -SWPTS-60 sandwich prep table. Whether you're in the foodservice industry or managing a restaurant, this prep table ensures your ingredients remain fresh and at the right temperature, preserving their quality.

2 Door 60" Sandwich Prep Table Prep Table | FG-SWPTS-60

Certified by ETL Electrical, ETL Sanitation, and DOE, the FG-SWPT-60 adheres to essential health and safety standards. Its stylish silver finish and swing-style solid doors not only convey a professional appearance but also offer easy access to your ingredients.



Invest in the future of your business with the Frigos Platinum FG-SWPTS-60. It's a powerful, energy-efficient, and reliable addition to any kitchen, designed to meet your needs for years to come. Explore our range of prep tables and kitchen equipment to optimize your operations. Choose Frigos Platinum for quality and performance.

Technical Data:

FRONT VIEW

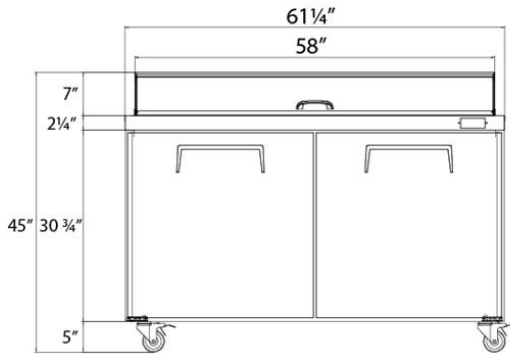

TOP VIEW

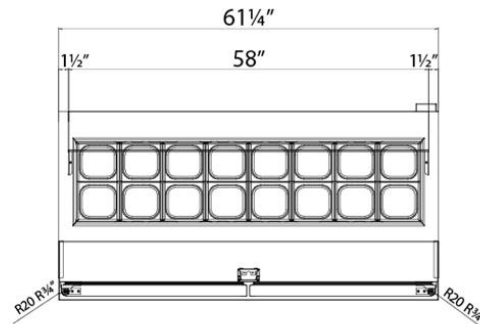

TOP VIEW

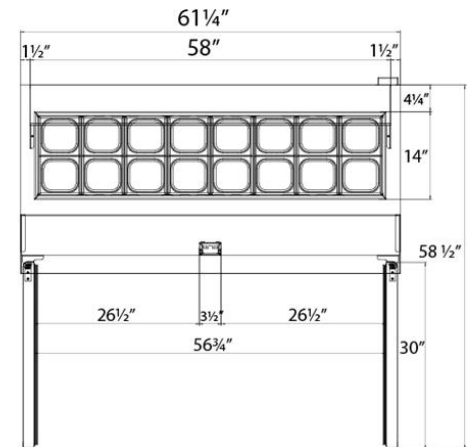

2 Door 60" Sandwich Prep Table Table | SKU: **FG-SWPTS-60**

The self-closing door adds convenience and saves energy by ensuring a proper seal at all times. Moving it around is effortless with four 5-inch casters that provide stability and mobility.



Warning: This product can expose you to chemicals including lead, which are known to the State of California to cause cancer, birth defects, or other reproductive harm. For more information, go to www.p65warnings.ca.gov.