

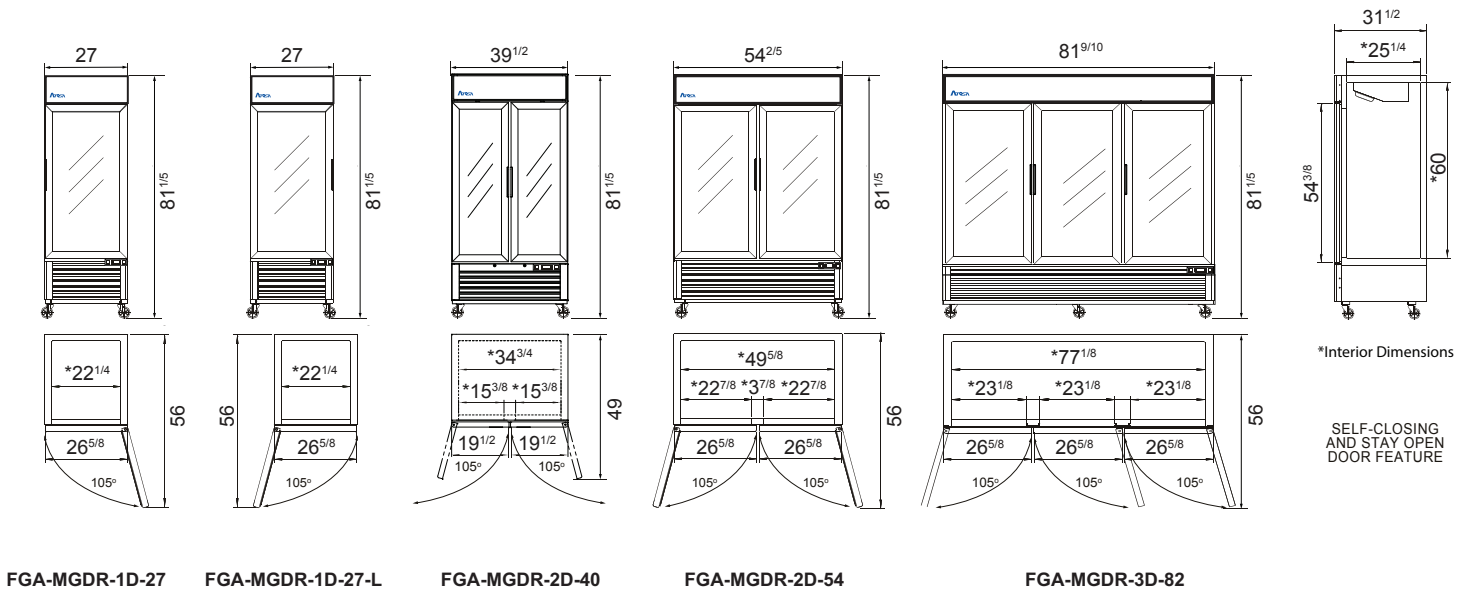

SPECIFICATIONS

Models	Door	Capacity (Cu.Ft.)	Shelves	Casters (inch)	Rated Current (A)	Voltage (V/Hz/Ph)	HP	Refrigerant	Exterior Dimensions (inch)	Net Weight (lb)	Gross Weight (lb)
FGA-MGDR-1D-27	1	19.4	4	2	2.1	115/60/1	1/7	R290	27×31 ^{1/2} ×81 ^{1/5}	293	326
FGA-MGDR-1D-27-L	1	19.4	4	2	2.1	115/60/1	1/7	R290	27×31 ^{1/2} ×81 ^{1/5}	293	326
FGA-MGDR-2D-40	2	28.5	8	2	3.2	115/60/1	1/5	R290	39 ^{1/2} ×31 ^{1/2} ×81 ^{1/5}	353	403
FGA-MGDR-2D-54	2	43.8	8	2	3.2	115/60/1	1/5	R290	54 ^{2/5} ×31 ^{1/2} ×81 ^{1/5}	485	540
FGA-MGDR-3D-82	3	69.5	12	2	4.2	115/60/1	1/4	R290	81 ^{9/10} ×31 ^{1/2} ×81 ^{1/5}	653	761

PLAN VIEW



FGA-MGDR-1D-27

FGA-MGDR-1D-27-L

FGA-MGDR-2D-40

FGA-MGDR-2D-54

FGA-MGDR-3D-82

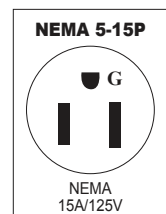

REV. 09/24