



## Frigos 3 Door Refrigerated Pizza Prep Table

SKU: FG-PZPT-93

- ★ Spacious: 30.8 cu ft capacity
- ★ Durable: Stainless steel exterior, painted aluminum interior
- ★ Efficient: Low energy usage (6.51 kW/24h)
- ★ Convenient: Self-closing doors, efficient LED lighting
- ★ Certified: ETL Electrical, ETL Sanitation, DOE
- ★ Mobility: Locking casters
- ★ Powerful: 1/2 HP compressor
- ★ Sleek: Silver finish, swing-style solid doors



<b>Refrigerant</b>	R290
<b>Horsepower (HP)</b>	1/2
<b>Voltage (V)</b>	115V/60Hz
<b>KW per 24h</b>	6.51 kW.h/24h
<b>Wattage</b>	738
<b>Shipping Weight (lbs)</b>	502.6
<b>Door Self Closed</b>	Yes
<b>Interior Material</b>	Painted Aluminum
<b>Exterior Material</b>	Stainless Steel
<b>Color</b>	Silver
<b>Door Style</b>	Swing
<b>Door Type</b>	Solid
<b>Number of Doors</b>	3
<b>Compressor Location</b>	Rear Mounted
<b>Shelf Capacity (lbs)</b>	85
<b>Plug Type</b>	NEMA 5-15P

Introducing our top-tier three-door commercial pizza prep table, model FG-PZPT-93, meticulously crafted to provide outstanding performance and reliability for your commercial kitchen. This pizza prep table boasts an expansive interior, featuring precise dimensions of 89 inches in width, 26 inches in depth, and 26 1/2 inches in height, offering ample storage with a substantial capacity of 30.8 cubic feet, thoughtfully designed to accommodate all your refrigerated items.

Crafted with a sturdy stainless steel exterior and a clean, easy-to-maintain painted aluminum interior, this unit seamlessly combines durability with a hygienic aesthetic. The thick 2-inch insulation, utilizing Cyclopentane, ensures superior temperature control, preserving the freshness of your stored products.

Item	Width (Inch)	Depth (Inch)	Height (Inch)
<b>Exterior</b>	93	32 1/4	41 3/4
<b>Interior</b>	89	26	26 1/2

Capacity (Cu Ft)	Number of Shelves
30.8	3

- Crafted with a robust stainless steel exterior, a pristine painted aluminum interior, and a dependable 304 stainless steel floor
- Generously Spacious: Equipped with three epoxy-coated shelves, each with the capacity to support up to 85 pounds
- Exceptionally Insulated: Boasts a substantial 2-inch insulation for optimal temperature retention
- Highly Powerful: Driven by an accurate 1/2 HP compressor for superior performance and reliability



**Kitchen Pro Restaurant Equipment:** [info@gokpe.com](mailto:info@gokpe.com) | [www.kitchenproequipment.com](http://www.kitchenproequipment.com) | T. 1-800-603-0033

Note: Specifications subject to change without notice.

Equipped with three robust shelves, each with a capacity to support up to 85 pounds, you'll find ample storage space for your ingredients and items. The built-in LED lighting guarantees exceptional visibility, simplifying the task of locating items within.

This pizza prep table is energy-efficient, utilizing eco-friendly R290 refrigerant and powered by a 1/2 horsepower compressor operating at 115V/60Hz. This translates to remarkably low energy consumption, merely 6.51 kW.h/24h, leading to significant long-term cost savings.

Hinge Location	Amps (A)	Hertz (Hz)	Temperature Range
Right/Left/Right	8.8	60	32°F to 40°F
Phase	Plastic Food Pans	Casters	Caster Size (inch)
1	Included	Included	5.75

The Frigos brand is synonymous with unwavering quality, and this pizza prep table is no exception. Whether you operate within the foodservice industry or a commercial kitchen, you can rely on this unit to maintain your products at their desired refrigerated temperatures, preserving their freshness and quality.

### 3 Door Refrigerated Pizza Prep Table | SKU: FG-PZPT-93

The self-closing doors not only enhance convenience but also contribute to energy efficiency by securely locking when needed. The unit's mobility is effortlessly facilitated by four 5 3/4-inch casters, ensuring stability.



Invest in the future of your business with our FG-PZPT-93 three-door commercial pizza prep table, perfect for your pizza prep needs. It embodies a powerful, energy-efficient, and reliable addition to any kitchen, meticulously designed to meet your needs for many years to come. And don't forget to explore our selection of pizza prep tables and other equipment to streamline your pizza-making process.

## Technical Data:

### FRONT VIEW

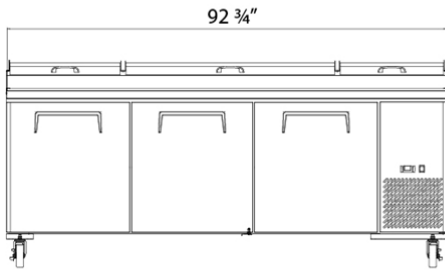

### TOP VIEW

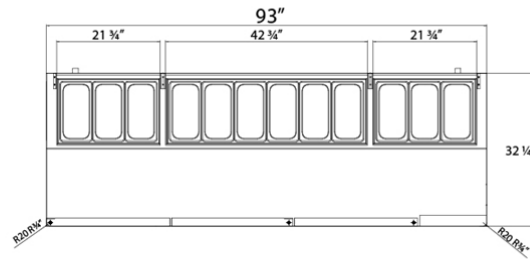

### TOP VIEW

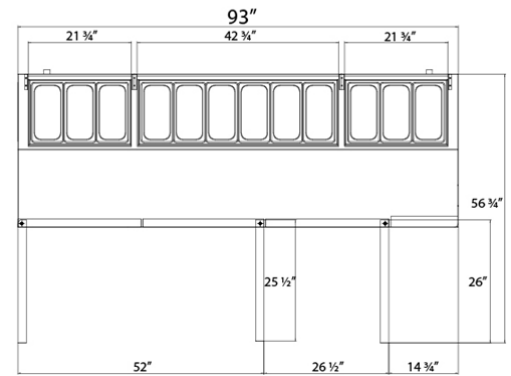

### 3 Door Refrigerated Pizza Prep Table | SKU: **FG-PZPT-93**

Our FG-PZPT-93 pizza prep table proudly bears ETL Electrical, ETL Sanitation, and DOE certifications, guaranteeing compliance with essential health and safety standards. Its sleek silver finish and swing-style solid doors not only project a professional appearance but also provide effortless access to your refrigerated inventory.

### SIDE VIEW

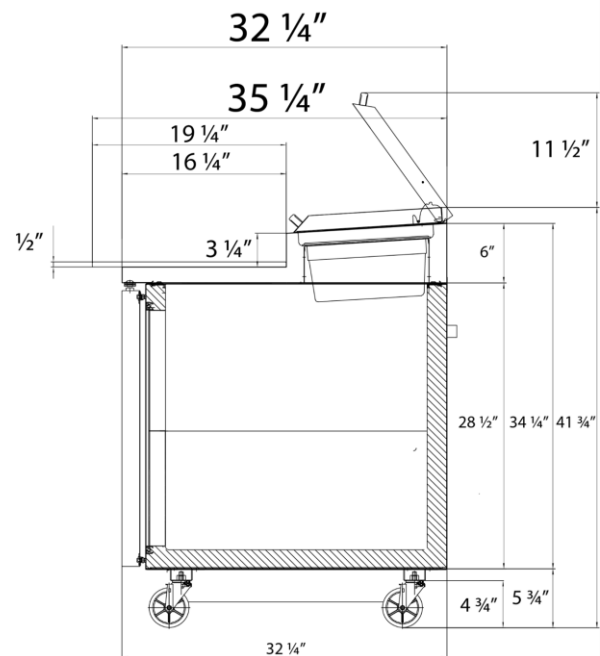

**Warning:** This product can expose you to chemicals including lead, which are known to the State of California to cause cancer, birth defects, or other reproductive harm. For more information, go to [www.p65warnings.ca.gov](http://www.p65warnings.ca.gov).