

# GLASS DOOR MERCHANDISER REFRIGERATOR SLIDING DOORS

Project Name: \_\_\_\_\_

Project Location: \_\_\_\_\_

Model #: \_\_\_\_\_ Quantity: \_\_\_\_\_

Available Warehouse: \_\_\_\_\_

**EM Series**

**Model: EMGR48**



## Refrigeration System

- Bottom mounted, self-contained and fully detachable Blizzard R290 condensing unit uses environmentally friendly, EPA-compliant R290 refrigerant with zero (0) Ozone Depletion Potential (ODP) and three (3) Global Warming Potential (GWP). Blizzard R290 is easily replaceable and requires no on-site brazing.
- Electronically commutated (ECM) fan motors achieve rapid cooling with less energy consumption.
- Full-length air duct system ensures optimal distribution of cold air.
- Time-initiated and temperature-terminated auto defrost cycle for seamless operation.
- Large capacity, corrosion-resistant condenser and evaporator coils.
- Self-maintaining, energy-efficient condensate drain pan requires no external drains or electric heaters.
- High performance, auto-reverse condenser fan motor supports compressor ventilation and condenser coil cleaning. Refer to owner's manual for full maintenance instructions.
- Pre-wired and ready to plug, 115V/60Hz/1Ph, NEMA 5-15P.

## Cabinet Construction

- Heavy duty white coated steel interior.
- Open spaced interior with no walls between compartments.
- Stainless steel floor interior has rounded corners and detachable drain plug for ease of cleaning.
- 2.5" thick high density polyurethane insulation.
- Four height adjustable screw legs.

## Lighting

- Shielded LED bar lighting with on/off switch provides bright, high color illumination at lower heat output.

## Doors

- Low emissivity double glass panes reflect UV rays for efficient cooling.
- Black PVC door frames.
- Self-closing with heavy duty door bumpers for impact absorption.
- Removable doors and stainless steel door tracks make cleaning an easy process.

## Shelving

- Four epoxy coated, steel wire shelves with airflow guard per section.
- Height adjustable stainless steel clips.

## Temperature Control

- Multi-function digital controller with easy to read LED display.
- Factory preset temperature, 35°F. Temperature setting range from 33°F to 54°F.
- Audible overheat protection alarm for compressor and condenser coil.

## Options

- Additional shelving.
- 5" or 3" swivel casters with locks on front set.
- 3.5" – 6" height-adjustable and interchangeable legs.



**Operating temperature range is 33°F ~ 54°F**



**5 YEAR Compressor  
3 YEAR Parts & Labor**



Please visit our website for updated Energy Efficiency information

Ref/ Frz/Dual	Doors	Capacity		Shelves	Refrigerant	HP	Power V-Hz-Ph	Amps	Crated Weight	Exterior Dimensions		
		Cu. Ft.	20 oz. Bottles							L	D	H*
REF	2	48	448	8	R-290	1/2	115-60-1	5.5	533 lbs (242kg)	53.125" (1349mm)	30.75" (781mm)	80.125" (2035mm)

(†)Based on evaporating temperature of 23°F (-5°C) & condensing temperature of 131°F (55°C). (►) Product capacity is calculated based on standard industry figures. (✳) Reference plan view for clarification on caster/unit height. If dimensions and capacity are critical, please contact Everest Refrigeration. Blizzard R290 replacement is at the sole discretion of Everest Refrigeration. Specifications subject to change without notice.

# GLASS DOOR MERCHANDISER REFRIGERATOR SLIDING DOORS

## EM Series Model: EMGR48

### DIMENSIONAL DATA

External Dimensions	L	53.125" (1349mm)
	D	30.75" (781mm)
	H*	80.125" (2035mm)
Crated Weight		533 lbs. (242kg)
Doors/Drawers/Lids		2
Max Weight Support (LBS)		-

### STORAGE DATA

Net Capacity Cu. Ft. ▶	48
Shelves	8
Barrels	-
20 oz. Bottles	448
12 oz. Bottles	-
12 oz. Cans	-
8" Mugs	-
# of Pans (Top)	-
# of Pans (Drawer)	-
Dividers	-
Trays	-

### ELECTRICAL DATA

Voltage	115-60-1
Full Load Amperage	5.5A
Feed Wires with Ground	3
Cord Length	9ft
NEMA Plug Type	 NEMA 5-15P

### REFRIGERATION DATA

Compressor Mounting	Bottom
Refrigerant	R-290
Compressor HP	1/2
BTU/HR †	N/A

### KEY

D	Door	R	Refrigerator
L	Lid	REF	Refrigerator
H	Half Door	F	Freezer
FD	Full Door	FRZ	Freezer
SD	Solid Door	DUAL	REF/FRZ Combo
GD	Glass Door	DR	Drawer

	Elevation	Right	Plan	3D	Back

### PLAN VIEW

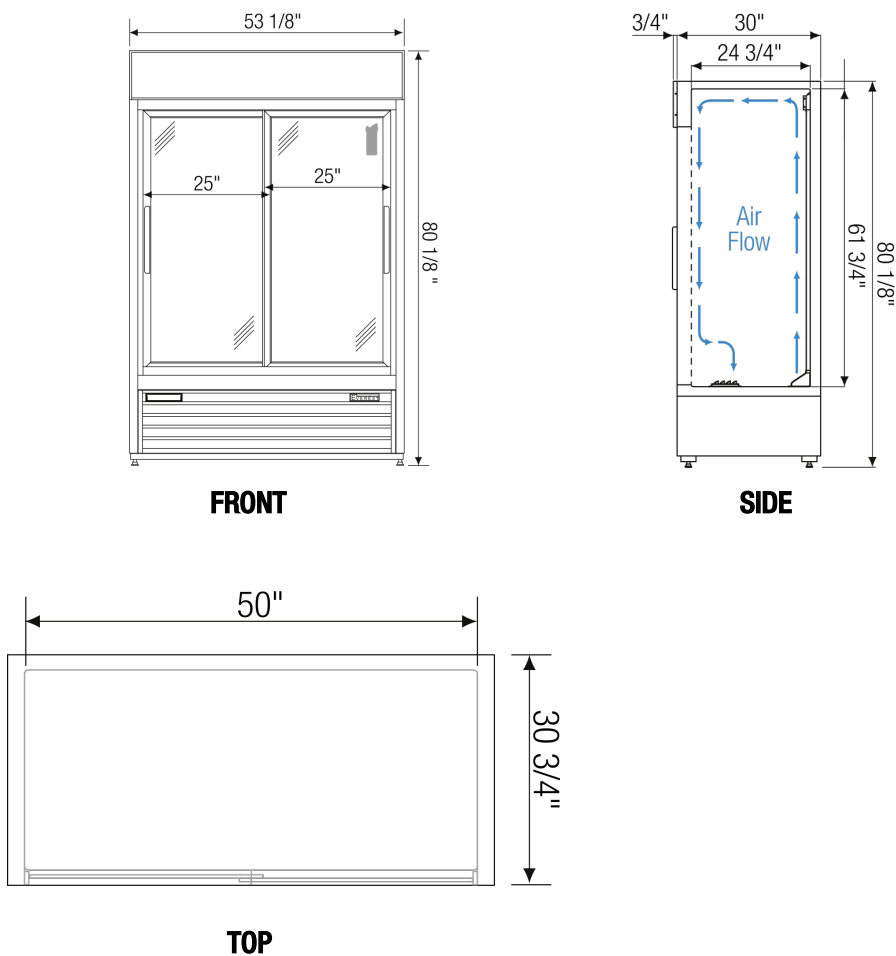

### ACCESSORIES & OPTIONS

Part Number	Description
<b>Additional Shelving</b>	Contact Everest Refrigeration for more information.
<b>AJL03-00</b>	Interchangeable Leg for Caster
<b>CASA3-01</b>	3" Overall Height Caster Assembly - (2) Front (2) Rear
<b>CASA5-01</b>	5" Overall Height Caster Assembly - (2) Front (2) Rear

(†) Based on evaporating temperature of 23°F (-5°C) & condensing temperature of 131°F (55°C). (▶) Product capacity is calculated based on standard industry figures. (✖) Reference plan view for clarification on caster/unit height. If dimensions and capacity are critical, please contact Everest Refrigeration. Blizzard R290 replacement is at the sole discretion of Everest Refrigeration. Specifications subject to change without notice.