

Ultra Max® Ultra Max® Ultra Max®

Ultra Max[®]

ELECTRIC GRIDDLES

MODELS

724TA, 736TA, 748TA, 760TA, 772TA

CHROME MODELS

724TCHSA, 736TCHSA, 748TCHSA, 760TCHSA, 772TCHSA

Installation and Operation Instructions

2M-Z16214 Rev. D 06/2019

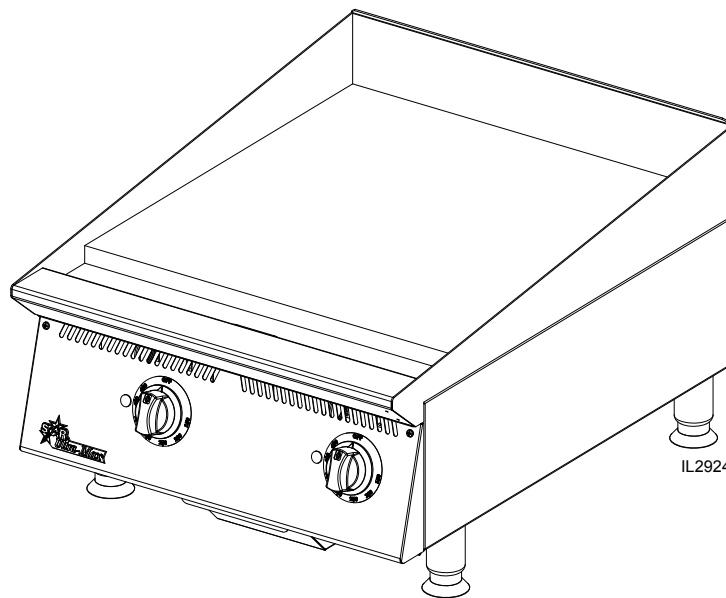

724TA



MODELS 760TA- & 772TA-
Not approved for Canada



ANSI/NSF 4

SAFETY SYMBOL



These symbols are intended to alert the user to the presence of important operating and maintenance instructions in the manual accompanying the appliance.

RETAIN THIS MANUAL FOR FUTURE REFERENCE NOTICE

Using any part other than genuine Star factory supplied parts relieves the manufacturer of all liability.

Star reserves the right to change specifications and product design without notice. Such revisions do not entitle the buyer to corresponding changes, improvements, additions or replacements for previously purchased equipment.

Due to periodic changes in designs, methods, procedures, policies and regulations, the specifications contained in this sheet are subject to change without notice. While Star International Holdings Inc., Company exercises good faith efforts to provide information that is accurate, we are not responsible for errors or omissions in information provided or conclusions reached as a result of using the specifications. By using the information provided, the user assumes all risks in connection with such use.

MAINTENANCE AND REPAIRS

Contact your local authorized service agent for service or required maintenance.

Please record the model number, serial number, voltage and purchase date in the area below and have it ready when you call to ensure a faster service.

Model No. _____
Serial No. _____
Voltage _____
Purchase Date _____

Authorized Service Agent Listing

Reference the listing provided with the unit

OR

for an updated listing go to:

Website: www.star-mfg.com
E-mail: customerservice@star-mfg.com

Service Help Desk

Business Hours: 8:00 am to 4:30 p.m. Central Standard Time

Telephone: (800) 264-7827

Fax: (314) 781-2714

E-mail: customerservice@star-mfg.com

Website: www.star-mfg.com

Mailing Address: Star Manufacturing International Inc.
265 Hobson Street
Smithville, TN 37166
U.S.A

**CAUTION****GENERAL INFORMATION**

This equipment is designed and sold for commercial use only by personnel trained and experienced in its operation and is not sold for consumer use in and around the home nor for use directly by the general public in food service locations. For equipment to be used by the general public, please contact the factory.

INSTALLATION

The griddles are equipped for the voltage indicated on the nameplate mounted on the front panel. They will operate on alternating current (AC) only.

**WARNING****DO NOT CONNECT TO DIRECT CURRENT (DC).**

The installation of the electric griddle should conform to the:

NATIONAL ELECTRIC CODE AND ALL LOCAL ELECTRIC CODES AND ORDINANCES AND THE LOCAL ELECTRIC COMPANY RULES AND REGULATIONS

For your protection we recommend that a qualified electrician install this griddle. He should be familiar with electrical installations and all electric codes. Proper connections and power supply are essential for efficient performance. The external wiring should be in conduit or an approved type of flexible cable suitable for operation at the temperature indicated on the wiring diagram, and of a proper size to carry the load. The supply circuit should be properly fused and equipped with a means of disconnecting, as required by local electrical code. **THE BODY OF THE GRIDDLE SHOULD BE GROUNDED (DO NOT GROUND TO A GAS SUPPLY LINE).**

EXHAUST CANOPY

Griddles inherently create a good deal of heat and smoke and should be installed under an efficient exhaust hood with flame proof filters. A vertical distance of not less than 48" shall be provided between the top of the appliance and filters or any other combustible material. Exhaust installation must conform to local codes.

AIR SUPPLY: Provisions for adequate air supply must be provided.

GENERAL OPERATING PROCEDURES

The Ultra-Max series electric griddles may be wired for operation in the field for either 1-phase or 3-phase power supplies by making line connections at the junction box(es) located at the rear of the unit. Models 724T-230/400V, 736T-230/400V & 748T-230/400V, should be wired for 3-phase power supply only. Two junction boxes are provided on the 760T & 772T for making line connections.

CONNECTING POWER SUPPLY

Detach cover on junction box at rear of unit. There is a terminal block for the supply connection in the junction box. Wires can be rerouted in the terminal block for 3phase hook-up. See wiring diagrams and model voltage on unit panel

LOCATING AND LEVELING THE UNIT

Do not install the unit closer than 1-inch from a side wall and/or closer than 1-inch from a rear wall. Make sure the unit is properly ventilated. Level unit by adjusting the (4) feet which have an adjustment of 1-3/4" (43.75mm) for accurate leveling and perfect line-up with other Ultra-Max series units.

GENERAL OPERATING PROCEDURES continued

SEASONING THE GRIDDLE HEATING SURFACE

Before initial use, clean the griddle surface thoroughly with hot soap and water. See Griddle care on page 4 for further information. After the griddle has been thoroughly cleaned, it should be seasoned to prevent food from sticking. Before using and after each thorough scouring, season the griddle heating surface in the following manner.

1. Remove any shipping material from the cooking surface and thoroughly clean the entire grill with hot soap and water.
2. Turn temperature control dials to 350°F (177°C).
3. Using a clean cloth, not a spatula, brush a thin film of cooking oil over the griddle cooking surface. This film should remain on the hot griddle surface for half an hour.
4. Remove the excess oil and wipe clean.
5. Apply another film of cooking oil over the hot cooking area for another half hour and again remove excess oil and wipe clean. The griddle surface should now be ready for use.

Even with careful seasoning, food may, to some extent, stick to the griddle cooking surface until the griddle plate is broken in.

TEMPERATURE CONTROL

The temperature controls are combination “ON/OFF” switches and thermostats. Turning the dial knob automatically maintains the selected heat range.

The Ultra-Max electric griddle line has one thermostat for every 12” (30cm) section of griddle that operates independently of one another. Each thermostat controls the section of the griddle above it and may be set at different temperatures as desired.

COOKING

Set the thermostat dial knob at the temperature desired. After a short pre-heating period, the thermostat will automatically maintain the selected temperature.

IDLING

During idle periods, to save on operating costs, lower the temperature setting of the thermostat to about 250°F (121°C). It is not necessary to maintain cooking temperature during idle periods, as the griddle can quickly be reheated to the desired temperature.

SIGNAL LIGHTS

Each thermostat has its own signal light which indicates when the unit’s control knob is in the on position. Cooking surface will be hot when the control knob is in this position.

CLEANING

GRIDDLE CARE (NON-CHROME SURFACES)

It takes very little time and effort to keep the griddle attractive and performing at top efficiency. If grease is permitted to accumulate, it will form a gummy cake and then carbonize into a hard substance which is extremely difficult to remove. To prevent this condition, the following suggestions for cleanliness should be followed:

1. After each use, scrape the griddle with a scraper or flexible spatula to remove excess grease and food. A waste drawer is provided for the drippings. If there is an accumulation of burned on grease and food, the griddle should be thoroughly scoured and re-seasoned. Use pumice or griddle stone while the griddle is warm. Do not use steel wool because of the danger of steel slivers getting into the food.
2. Daily, use a clean cloth and a good non-abrasive cleaner to clean the stainless steel body of the griddle. Wipe the polished front with a soft cloth.
3. At least once a day, remove the waste drawer and wash in the same way as an ordinary cooking utensil. The drawers are removed by pulling forward until they are released from their track.

GRIDDLE CARE (CHROME SURFACES)

(Chrome surface griddles are marked with "CHS" at the end of the model number designation on the nameplate.) It takes very little time and effort to keep this Industrial Chrome griddle surface sparkling clean and performing at top efficiency. DO NOT allow grease to accumulate as it will carbonize and become difficult to remove. To prevent this condition, the following cleaning suggestions should be followed:

1. Remove excess oil and food regularly with a 4" (100mm) wide razor sharp type scraper and wipe surface with a damp cloth if desired.
2. Following the scraping, for end of the day cleaning, a damp cloth and a non-silicated, non-abrasive, non-chlorinated cleaner such as Bon-Ami may be used to wipe surface clean, followed by wiping with clean wet cloth.
3. Follow steps 2 and 3 from Griddle Care (Non-Chrome Surfaces).

ON CHROME SURFACES:

1. **Never** use pumice, griddle stones, or abrasives on the surface.
2. **Never** strike the griddle surface with a sharp instrument or spatula edge.
3. **Never** use steel wool.
4. **Never** use commercial liquid grill cleaner on the griddle surface.
5. Abusing the surface voids the warranty.

GREASE DRAWER

A grease drawer is located at the front can be removed for cleaning by pulling drawer forward. This drawer contains hot grease and should be checked and emptied when necessary or at least once a day.

EXERCISE EXTREME CARE IN HANDLING THE GREASE DRAWER CONTAINING HOT GREASE.

Never pour large amounts of water onto a hot griddle surface, the sudden temperature change generated by the steam can cause the surface to warp and possibly the thermal sensors in your hood fire suppression system to discharge. Instead follow the cleaning procedures in this manual.

MAINTENANCE AND REPAIRS

Contact the factory, a service representative, or a local service company for service or required maintenance.



2M-Z16214, Ultra-Max Electric Griddle



LIMITED EQUIPMENT WARRANTY

Star Manufacturing [as well as its subsidiaries, Toastmaster and Holman] warranties new products to be free from defects in material and/or workmanship for a period of one [1] year from the date of original installation, except as noted below. Defects that occur as a result of normal use, within the time period and limitations defined in this warranty, will at Star’s discretion have the parts replaced or repaired by Star or a Star-authorized service agency.

THIS WARRANTY IS SUBJECT TO ALL LISTED CONDITIONS.

Repairs performed under this warranty are to be performed by a Star authorized service agency. Star will not be responsible for charges incurred or service performed by non-authorized repair agencies. In all cases, the nearest Star-authorized service agency must be used. Star will be responsible for normal labor charges incurred in the repair or replacement of a warranted product within 50 miles (80.5 km) of an authorized service agency. Time and expense charges for anything beyond that distance will be the responsibility of the owner. All labor will need to be performed during regular service hours. Any overtime premium will be charged to the owner. For all shipments outside the U.S.A. and Canada, please see the International Warranty for specific details. It is the responsibility of the owner to inspect and report any shipping damage claims, hidden or otherwise, promptly following delivery. No mileage or travel charges will be honored on any equipment that is deemed portable. In general, equipment with a cord and plug weighing less than 50 lb. (22.7 kg) is considered portable and should be taken or shipped to the closest authorized service agency, transportation prepaid.

PORTABLE EQUIPMENT EXAMPLES

- 514LL fryer
- 15MC and 18MCP hot food merchandisers
- QCS1, QCS2, and RCS2 toasters
- 16PD-A pretzel merchandisers
- Condiment dispensers except HPD- and SPD-series models
- All pop-up toasters
- All pastry display cabinets
- All heat lamps
- J4R popcorn machine
- 12NCPW and 15NCPW nacho merchandisers
- Nacho cheese warmers except 11WLA-series models
- Specialty food warmers except 130R, 11RW, and 11WSA models
- All butter dispensers
- All nacho chip merchandisers
- All accessories

CONTACT

Should you require any assistance regarding the operation or maintenance of any Star equipment; write, phone, fax or email our service department. In all correspondence mention the model number and serial number of your unit, as well as the voltage or type of gas you are using.

Business hours are 8:00 a.m. to 4:30 p.m. Central Standard Time (CST)

Telephone: (800)-264-7827

Fax: (314)-781-2714

Email: Customerservice@star-mfg.com

www.star-mfg.com

WARRANTY EXCLUSIONS

THE FOLLOWING WILL NOT BE COVERED UNDER WARRANTY.

- Any product which has not been used, cleaned, maintained, or installed in accordance with the directions published in the appropriate installation sheet and/or owner’s manual as well as national and local codes, including incorrect gas, electrical, or water connection. Star is not liable for any unit which has been mishandled, abused, misapplied, subjected to chlorides, harsh chemicals, or caustic cleaners, damaged from exposure to hard water, modified by unauthorized personnel, damaged by flood, fire, or other acts of nature [or God], or which have an altered or missing serial number.
- Installation, labor, and job checkouts, calibration of heat controls, air and gas burner/bypass/pilot adjustments, gas or electrical system checks, voltage and phase conversions, cleaning of equipment, or seasoning of griddle surface.
- Replacement of fuses or resetting of circuit breakers, safety controls, or reset buttons.
- Replacement of broken or damaged glass components, quartz heating elements, and light bulbs.
- Labor charges for all removable parts in gas charbroilers and hotplates, including but not limited to burners, grates, and radiants.
- Any labor charges incurred by delays, waiting time, or operating restrictions that hinder a service technician’s ability to perform service.
- Replacement of items subject to normal wear or items that can easily be replaced during a daily cleaning routine, such as but not limited to knobs, bulbs, fuses, quartz heating elements, baskets, racks, and grease drawers.
- Components that should be replaced when damaged or worn, but have been field-repaired instead [eg. field-welded fry pots]
- Any loss of business or profits.

PRODUCTS	PARTS	LABOR
Star-Ultra Max® fryers, griddles, charbroilers, and hotplates	2 years	2 years
Star-Max® fryers, griddles, charbroilers, and hotplates	2 years	2 years
Jetstar® popcorn poppers	2 years	2 years
Staltek™ roller grill coatings	5 years	
Cast iron grates, burners; and burner shields	180 days	
Star, Toastmaster, or Holman parts sold to repair equipment	90 days	
Service First	1 year	

2M-Z16214, Ultra-Max Electric Griddle

NOTE: Wattage is 4.35 kw per heated zone. See unit nameplate on front panel for correct supply voltage.

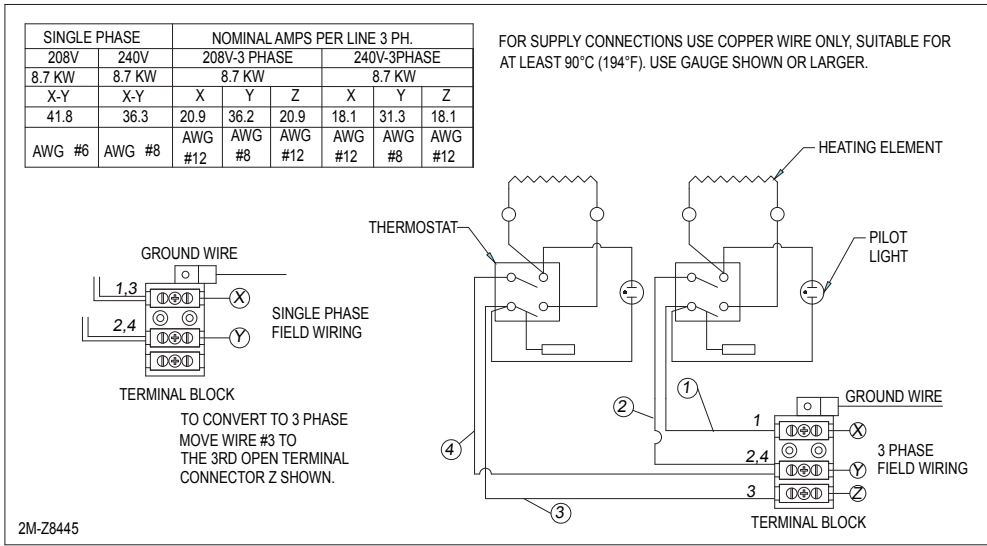

MODEL 724T AND 760T (1SIDE)

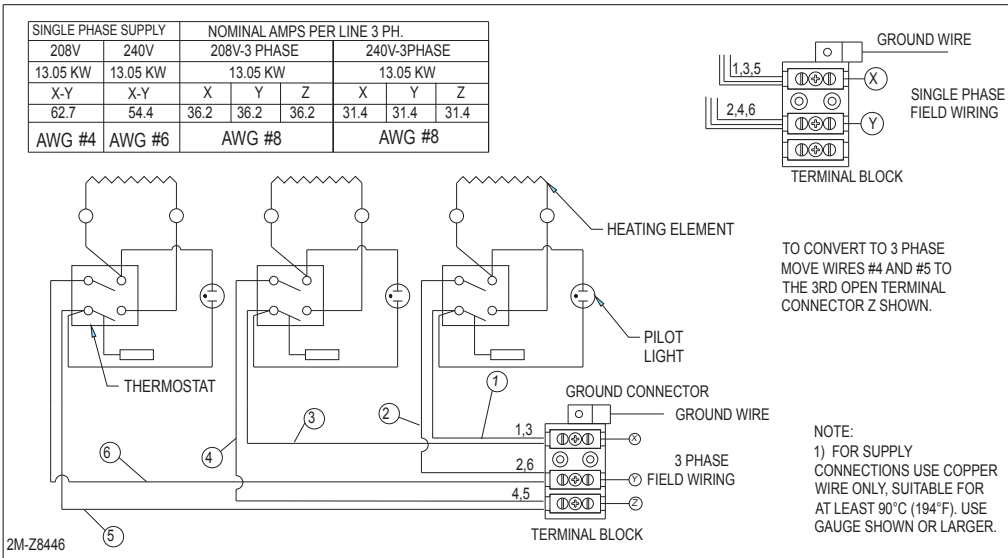

MODEL 736T, 760T (1 SIDE), 772T (BOTH SIDES EACH)

2M-Z16214, Ultra-Max Electric Griddle

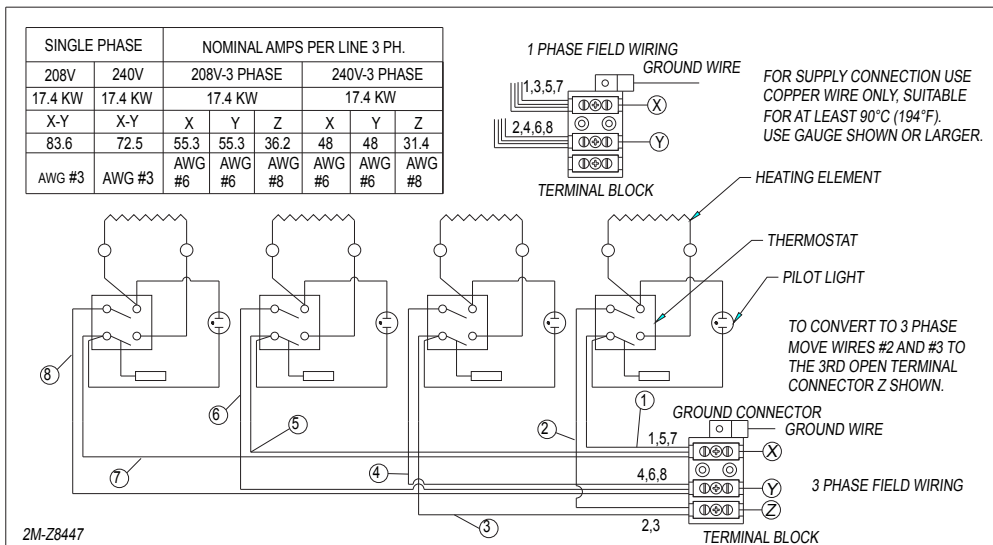

MODEL 748T

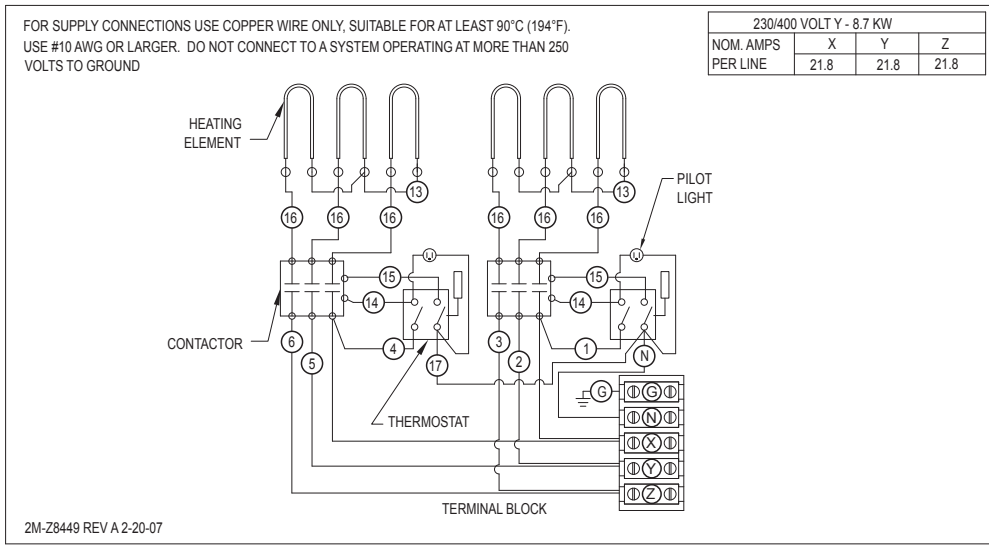

MODEL 724T 230V 3 PHASE

NOTE: Wattage is 4.35 kw per heated zone. (1450 watts per-element) See unit nameplate for correct supply voltage.

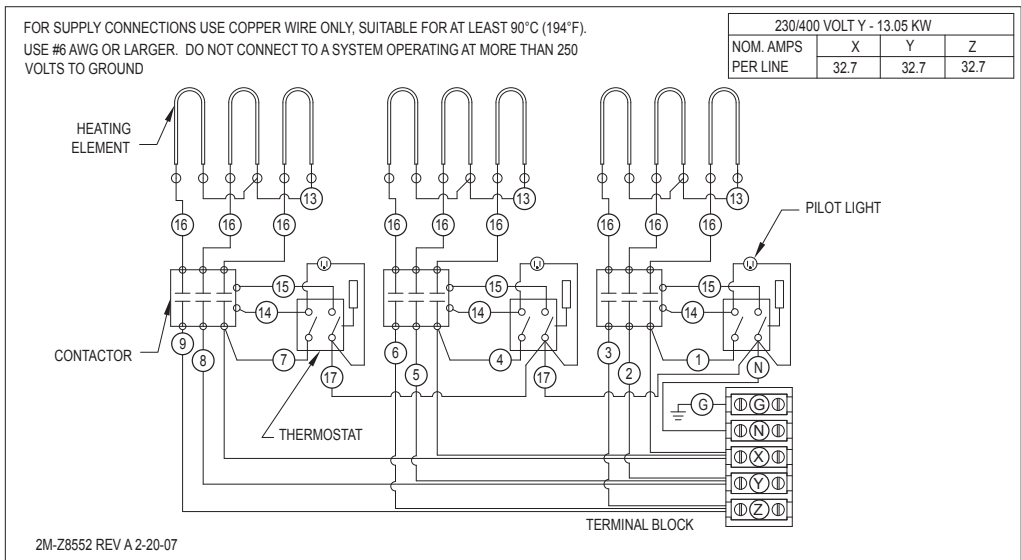

MODEL 736T 230V 3 PHASE

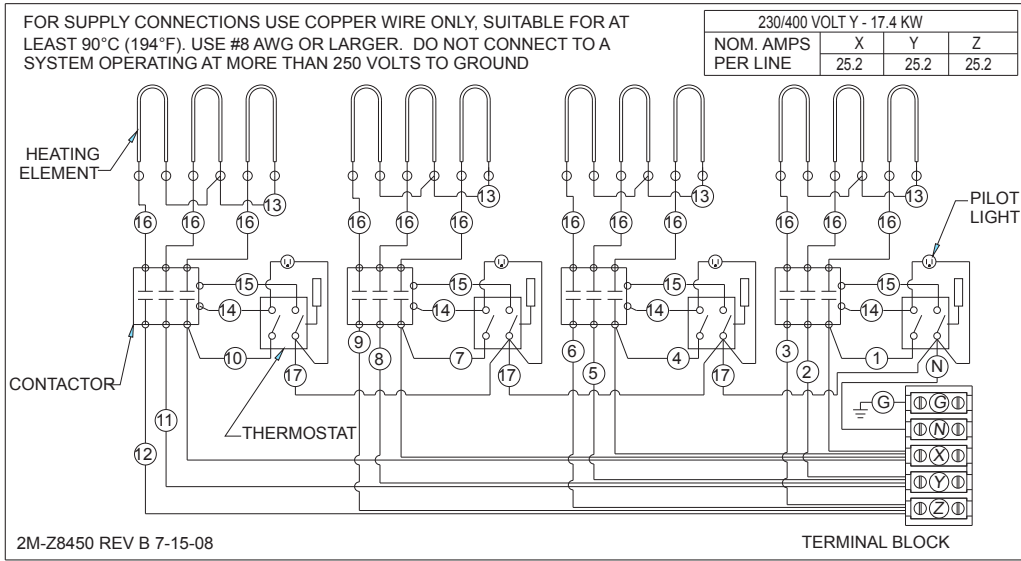

MODEL 748T 230V 3 PHASE

2M-Z16214, Ultra-Max Electric Griddle

FOR SUPPLY CONNECTIONS USE COPPER WIRE ONLY, SUITABLE FOR AT LEAST 90°C (194°F). USE #8 AWG OR LARGER. DO NOT CONNECT TO A SYSTEM OPERATING AT MORE THAN 250 VOLTS TO GROUND

760T 230/400 VOLT Y - 21.75 KW			
NOM. AMPS PER LINE	X	Y	Z
	31.5	31.5	31.5

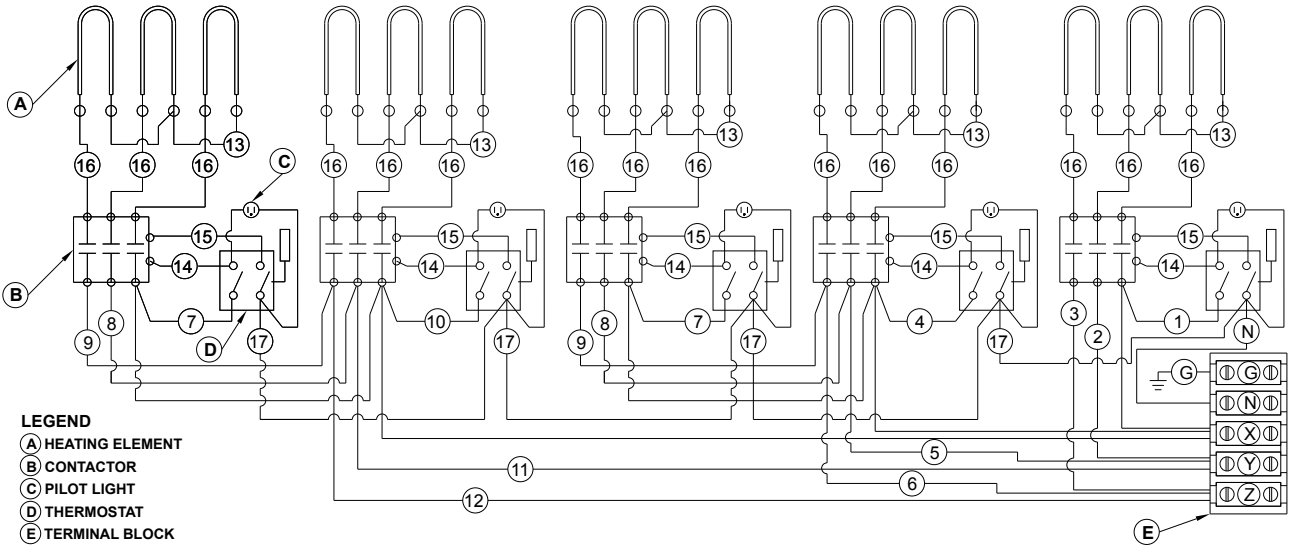

MODEL 760T 230/400V Y 3 PHASE

2M-Z11776

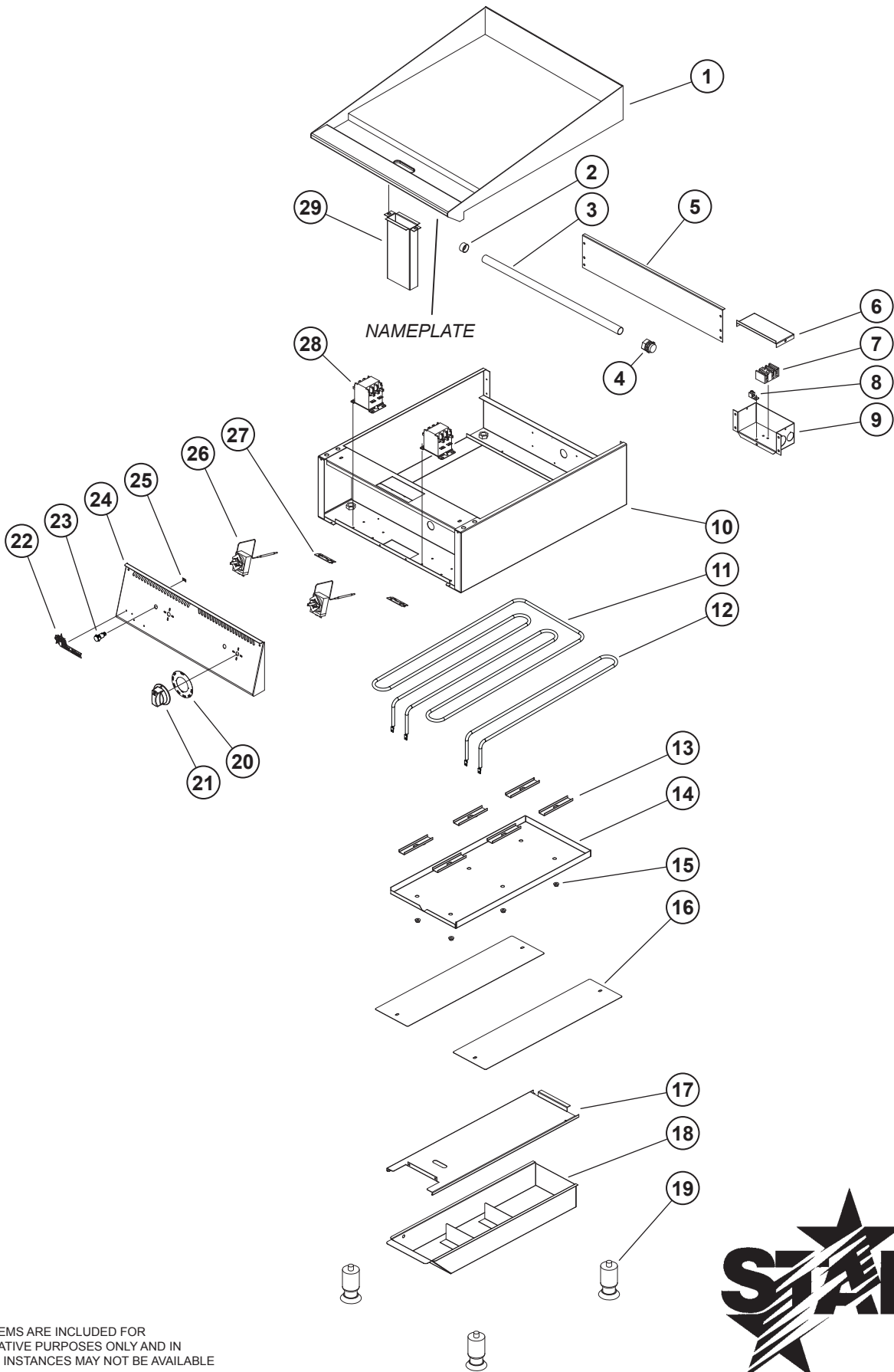

SOME ITEMS ARE INCLUDED FOR ILLUSTRATIVE PURPOSES ONLY AND IN CERTAIN INSTANCES MAY NOT BE AVAILABLE

MODEL 724TA, 736TA, 748TA, 760TA, 772TA

STAR MANUFACTURING INTERNATIONAL, INC.

SK2122

REV. A. 8/02/2012



2M-Z16214, Ultra-Max Electric Griddle

PARTS LIST

November 14, 2014, Rev. A

Model: 724TA ULTRA-MAX ELECTRIC GRIDDLE				
Fig No.	Part No.	Description	Qty	Application
1	G5-824034	GRIDDLE PLATE ASSY 724	1	724TA
	G5-824035	GRIDDLE PLATE ASSY 724CHS		724TCHSA
2	2E-Z8356	3/4" PLASTIC END BUSHING	1	
3	2E-Z8361	3/4"x 22 3/4 EMT TUBE	1	
4	2E-Z8358	3/4" EMT CONNECTOR	1	
5	G5-Z8491	REAR PANEL 24	1	
6	G5-Z10349	ELECTRICAL BOX COVER	1	230V
	G5-Z8481	JUNCTION BOX COVER		
7	2E-Z8482	TERMINAL BLOCK	1	208/240V
	2E-Z9565	TERMINAL BLOCK 5 POS #4		230V
8	2E-Z8423	TERMINAL LUG 14-2 AL-CU	1	208/240V
9	G5-824023	JUNCTION BOX ASSY	1	208/240V
	G5-Z10348	ELECTRICAL BOX		230V
10	G5-824021	BODY ASSY 24"	1	
11	2N-Z8484	HEATING ELEMENT 4350W 208V	2	208V
	2N-Z8485	HEATING ELEMENT 4350W 240V		240V
12	2N-Z8487	HEATING ELEMENT 1450W	6	230V
13	G5-Z8489	HEATER ELEMENT CLAMPS	12	
14	G5-Z8488	HEATER ELEMENT SHIELD	2	
15	2C-6517	NUT 1/4-20 HEX STL NP	24	
16	G5-Z8468	BOTTOM PANEL 24	2	
17	G5-Z8515	DRAWER SLIDE	1	
18	G5-824014	GREASE DRAWER ASSY	1	
19	2A-Z4614	FOOT, FLANGED NON-SKID	4	
	2R-Z19119	FOOT, TAPERED STEEL		
20	2M-Z16040	GRAPHIC, DIAL 450F CW	2	
21	G3-624330	KNOB ASSEMBLY LG E-F KEY	2	
22	2M-Z15805	LOGO, ULTRA-MAX	1	
23	2J-Y6690	PILOT LIGHT 240V	2	
24	G5-Z16208	FRONT PANEL - 724TA	1	
25	2C-8477	CLIP .125 PO STL PHOS	4	
26	2T-Z5958	THERMOSTAT	2	
27	2P-Z8478	HINGE, 2.5" U-MAX	2	
28	2E-302789	CONTACTOR 50A 3 PH 208	2	724TA-230V
29	G5-824012	CHUTE ASSEMBLY	1	
NI	2M-Z8445	WIRING DIAGRAM LABEL 24"	1	724TA
NI	2M-Z8449	WIRING DIAGRAM LABEL 24CE	1	724TA-230V, 724TCHSA-230V

2M-Z16214, Ultra-Max Electric Griddle

**IMPORTANT: WHEN ORDERING, SPECIFY VOLTAGE OR TYPE GAS DESIRED
INCLUDE MODEL AND SERIAL NUMBER**

PAGE 1
OF 1

Some items are included for illustrative purposes only and in certain instances may not be available.



PARTS LIST

November 14, 2014, Rev. A

Model: 736TA ULTRA-MAX ELECTRIC GRIDDLE				
Fig No.	Part No.	Description	Qty	Application
1	G5-836034	GRIDDLE PLATE ASSY 736	1	736TA
	G5-836035	GRIDDLE PLATE ASSY 736CHS		736TCHSA
2	2E-Z8356	3/4" PLASTIC END BUSHING	1	
3	2E-Z8361	3/4"x 22 3/4 EMT TUBE	1	
4	2E-Z8358	3/4" EMT CONNECTOR	1	
5	G5-Z8492	REAR PANEL 36	1	
6	G5-Z10349	ELECTRICAL BOX COVER	1	230V
	G5-Z8481	JUNCTION BOX COVER		
7	2E-Z8482	TERMINAL BLOCK	1	208/240V
	2E-Z9565	TERMINAL BLOCK 5 POS #4		230V
8	2E-Z8423	TERMINAL LUG 14-2 AL-CU	1	208/240V
9	G5-824023	JUNCTION BOX ASSY	1	
	G5-Z10348	ELECTRICAL BOX		230V
10	G5-836019	BODY ASSY 36"	1	
11	2N-Z8484	HEATING ELEMENT 4350W 208	3	208V
	2N-Z8485	HEATING ELEMENT 4350W 240		240V
12	2N-Z8487	HEATING ELEMENT 1450W 230	9	230V
13	G5-Z8489	HEATER ELEMENT CLAMPS	18	
14	G5-Z8488	HEATER ELEMENT SHIELD	3	
15	2C-6517	NUT 1/4-20 HEX STL NP	36	
16	G5-Z8468	BOTTOM PANEL 24	1	
	G5-Z8469	BOTTOM PANEL 36		
17	G5-Z8515	DRAWER SLIDE	1	
18	G5-824014	GREASE DRAWER ASSY	1	
19	2A-Z4614	FOOT- 2 IN D.X 4 IN L.	4	
	2R-Z19119	FOOT, TAPERED STEEL		
20	2M-Z16040	GRAPHIC, DIAL 450F CW	3	
21	G3-624330	KNOB ASSEMBLY LG E-F KEYT	3	
22	2M-Z15805	LOGO, ULTRA-MAX	1	
23	2J-Y6690	PILOT LIGHT 240V	3	
24	G5-Z16153	FRONT PANEL - 736TA	1	
25	2C-8477	CLIP .125 PO STL PHOS	4	
26	2T-Z5958	THERMOSTAT	3	
27	2P-Z8478	HINGE, 2.5" U-MAX	2	
28	2E-302789	CONTACTOR 50A 3PH 208V	3	230V
29	G5-824012	CHUTE ASSEMBLY	1	
NI	2M-Z8446	WIRING DIAGRAM LABEL 36"	1	
NI	2M-Z8552	WIRING DIAGRAM LABEL 36CE	1	736TA-230V, 736TCHSA-230V

2M-Z16214, Ultra-Max Electric Griddle

**IMPORTANT: WHEN ORDERING, SPECIFY VOLTAGE OR TYPE GAS DESIRED
INCLUDE MODEL AND SERIAL NUMBER**

**PAGE 1
OF 1**

Some items are included for illustrative purposes only and in certain instances may not be available.



PARTS LIST

November 14, 2014, Rev. A

Model: 748TA ULTRA-MAX ELECTRIC GRIDDLE				
Fig No.	Part No.	Description	Qty	Application
1	G5-848034	GRIDDLE PLATE ASSY 748	1	748TA
	G5-848035	GRIDDLE PLATE ASSY 748CHS		748TCHSA
2	2E-Z8356	3/4" PLASTIC END BUSHING	1	
3	2E-Z8361	3/4"x 22 3/4 EMT TUBE	1	
4	2E-Z8358	3/4" EMT CONNECTOR	1	
5	G5-Z8493	REAR PANEL 48	1	
6	G5-Z8481	JUNCTION BOX COVER	1	208/240V
	G5-Z10349	ELECTRICAL BOX COVER		230V
7	2E-Z8482	TERMINAL BLOCK	1	208/240V
	2E-Z9565	TERMINAL BLOCK 5 POS #4		230V
8	2E-Z8423	TERMINAL LUG 14-2 AL-CU	1	208/240V
9	G5-824023	JUNCTION BOX ASSY	1	208/240V
	G5-Z10348	ELECTRICAL BOX		230V
10	G5-848019	BODY ASSY 48"	1	
11	2N-Z8484	HEATING ELEMENT 4350W 208	4	208V
	2N-Z8485	HEATING ELEMENT 4350W 240V		240V
12	2N-Z8487	HEATING ELEMENT 1450W 230V	12	230V
13	G5-Z8489	HEATER ELEMENT CLAMPS	24	
14	G5-Z8488	HEATER ELEMENT SHIELD	4	
15	2C-6517	NUT 1/4-20 HEX STL NP	48	
16	G5-Z8468	BOTTOM PANEL 24	1	
	G5-Z8470	BOTTOM PANEL 48		
17	G5-Z8515	DRAWER SLIDE	1	
18	G5-824014	GREASE DRAWER ASSY	1	
19	2A-Z4614	FOOT- 2 IN D.X 4 IN L.	4	
	2R-Z19119	FOOT, TAPERED STEEL		
20	2M-Z16040	GRAPHIC, DIAL 450F CW	4	
21	G3-624330	KNOB ASSEMBLY LG E-F KEYT	4	
22	2M-Z15805	LOGO, ULTRA-MAX	1	
23	2J-Y6690	PILOT LIGHT 240V	4	
24	G5-Z16209	FRONT PANEL - 748TA	1	
25	2C-8477	CLIP .125 PO STL PHOS	3	
26	2T-Z5958	THERMOSTAT	4	
27	2P-Z8478	HINGE, 2.5" U-MAX	2	
28	2E-302789	CONTACTOR 50A 3 PHASE 208	4	
29	G5-824012	CHUTE ASSEMBLY	1	
NI	2M-Z8447	WIRING DIAGRAM LABEL 48"	1	208/240V
NI	2M-Z8450	WIRING DIAGRAM LABEL 48CE	1	230V

2M-Z16214, Ultra-Max Electric Griddle

**IMPORTANT: WHEN ORDERING, SPECIFY VOLTAGE OR TYPE GAS DESIRED
INCLUDE MODEL AND SERIAL NUMBER**

PAGE 1
OF 1

Some items are included for illustrative purposes only and in certain instances may not be available.



PARTS LIST

November 14, 2014, Rev. A

Model: 760TA ULTRA-MAX ELECTRIC GRIDDLE				
Fig No.	Part No.	Description	Qty	Application
1	G5-860034	GRIDDLE PLATE ASSY 760	1	760TA
	G5-860035	GRIDDLE PLATE ASSY 760CHS		760TCHSA
2	2E-Z8358	3/4" EMT CONNECTOR	2	208/240V
			1	230V
3	2E-Z8361	3/4"x 22 3/4 EMT TUBE	2	208/240V
			1	230V
4	2E-Z8356	3/4" PLASTIC END BUSHING	2	208/240V
			1	230V
5	G5-Z8494	REAR PANEL 60	1	760TA-208V
6	G5-Z10349	ELECTRICAL BOX COVER	1	230V
	G5-Z8481	JUNCTION BOX COVER	2	208/240V
7	2E-Z8482	TERMINAL BLOCK	2	208/240V
	2E-Z9565	TERMINAL BLOCK 5 POS #4	1	230V
8	2E-Z8423	TERMINAL LUG 14-2 AL-CU	2	208/240V
9	G5-824023	JUNCTION BOX ASSY	2	208/240V
	G5-Z10348	ELECTRICAL BOX	1	230V
10	G5-860012	BODY ASSY 760T 230V	1	230V
	G5-860019	BODY ASSY 60"		208/240V
11	2N-Z8484	HEATING ELEMENT 4350W 208	5	208V
	2N-Z8485	HEATING ELEMENT 4350W 240		240V
12	2N-Z8487	HEATING ELEMENT 1450W 230	15	230V
13	G5-Z8489	HEATER ELEMENT CLAMPS	30	
14	G5-Z8488	HEATER ELEMENT SHIELD	5	
15	2C-6517	NUT 1/4-20 HEX STL NP	60	
16	G5-Z8468	BOTTOM PANEL 24	2	
	G5-Z8471	BOTTOM PANEL 60	1	
17	G5-Z8515	DRAWER SLIDE	2	
18	G5-824014	GREASE DRAWER ASSY	2	
19	2A-Z4614	FOOT- 2 IN D.X 4 IN L.	4	
	2R-Z19119	FOOT, TAPERED STEEL		
20	2M-Z16040	GRAPHIC, DIAL 450F CW	5	
21	G3-624330	KNOB ASSEMBLY LG E-F KEYT	5	
22	2M-Z15805	LOGO, ULTRA-MAX	1	
23	2J-Y6690	PILOT LIGHT 240V	5	
24	G5-Z16210	FRONT PANEL - 760TA	1	
25	2C-8477	CLIP .125 PO STL PHOS	4	
26	2T-Z5958	THERMOSTAT	5	
27	2P-Z8478	HINGE, 2.5" U-MAX	2	
28	2E-302789	CONTACTOR 50A 3 PH 208	5	
29	G5-824012	CHUTE ASSEMBLY	2	
NI	2M-Z11776	LABEL-WIRE DIAGRAM	1	230V
NI	2M-Z8445	WIRING DIAGRAM LABEL 24"	1	208/240V

2M-Z16214, Ultra-Max Electric Griddle

**IMPORTANT: WHEN ORDERING, SPECIFY VOLTAGE OR TYPE GAS DESIRED
INCLUDE MODEL AND SERIAL NUMBER**

PAGE 1
OF 1

Some items are included for illustrative purposes only and in certain instances may not be available.



PARTS LIST

November 14, 2014, Rev. A

Model: 772TA ULTRA-MAX ELECTRIC GRIDDLE				
Fig No.	Part No.	Description	Qty	Application
1	G5-872034	GRIDDLE PLATE ASSY 772	1	772T
	G5-872035	GRIDDLE PLATE ASSY 772CHS		772TCHSA
2	2E-Z8356	3/4" PLASTIC END BUSHING	2	
3	2E-Z8361	3/4"x 22 3/4 EMT TUBE	2	
4	2E-Z8358	3/4" EMT CONNECTOR	2	
5	G5-Z8495	REAR PANEL 72	1	
6	G5-Z8481	JUNCTION BOX COVER	2	
7	2E-Z8482	TERMINAL BLOCK	2	
8	2E-Z8423	TERMINAL LUG 14-2 AL-CU	2	
9	G5-824023	JUNCTION BOX ASSY	2	
10	G5-872019	BODY ASSY 72"	1	
11	2N-Z8484	HEATING ELEMENT 4350W 208	6	208V
	2N-Z8485	HEATING ELEMENT 4350W 240		240V
13	G5-Z8489	HEATER ELEMENT CLAMPS	36	
14	G5-Z8488	HEATER ELEMENT SHIELD	6	
15	2C-6517	NUT 1/4-20 HEX STL NP	60	
16	G5-Z8468	BOTTOM PANEL 24	2	
16	G5-Z8472	BOTTOM PANEL 72	1	
17	G5-Z8515	DRAWER SLIDE	2	
18	G5-824014	GREASE DRAWER ASSY	2	
19	2A-Z4614	FOOT- 2 IN D.X 4 IN L.	4	
	2R-Z19119	FOOT, TAPERED STEEL		
20	2M-Z16040	GRAPHIC, DIAL 450F CW	6	
21	G3-624330	KNOB ASSEMBLY LG E-F KEYT	6	
22	2M-Z15805	LOGO, ULTRA-MAX	1	
23	2J-Y6690	PILOT LIGHT 240V	6	
24	G5-Z16211	FRONT PANEL - 772TA	1	
25	2C-8477	CLIP .125 PO STL PHOS	4	
26	2T-Z5958	THERMOSTAT	6	
27	2P-Z8478	HINGE, 2.5" U-MAX	2	
29	G5-824012	CHUTE ASSEMBLY	2	
NI	2M-Z8446	WIRING DIAGRAM LABEL 36"	2	

2M-Z16214, Ultra-Max Electric Griddle

**IMPORTANT: WHEN ORDERING, SPECIFY VOLTAGE OR TYPE GAS DESIRED
INCLUDE MODEL AND SERIAL NUMBER**

PAGE 1
OF 1

Some items are included for illustrative purposes only and in certain instances may not be available.



STAR MANUFACTURING INTERNATIONAL INC.
Star - Holman - Lang - Wells - Toastmaster
265 HOBSON ST. SMITHVILLE, TN 37166
(800) 264-7827
www.star-mfg.com