



## COMPETITOR SERIES®



**C-1FG-HC**



**C-2FG-HC**

# GLASS DOOR REACH-IN FREEZERS

- Beautiful ergonomic construction & rounded corners
- Digital temperature controller & read-out
- All stainless steel exterior and interior
- Forced air refrigeration system
- Recessed door handles
- Glass doors with LED interior lighting
- Door locks
- 90 degree hold open door feature for loading products
- Top mount compressor for enhanced efficiency
- Pre-installed casters and shelving
- Auto-defrost
- Air plenum across back wall for even temperature distribution throughout cabinet interior
- All Natural R290 Hydrocarbon Refrigerant
- US Department of Energy Certified
- Air Pressure Relief Valve for ease of opening doors
- Migali® Protection Plan: 2 Year Parts & Labor Warranty, 5 Years Compressor Warranty

MODEL	DOORS	CAPACITY CU/FT	SHELVES	H/P	AMPS	VOLTAGE	ENERGY CONSUMPTION KWH/24 HR	PLUG TYPE	TEMP RANGE	EXTERIOR DIMENSIONS W X D X H*	INTERIOR DIMENSIONS W X D X H	PACKAGED DIMENSIONS W X D X H	WEIGHT	PACKAGED WEIGHT
C-1FG-HC	1	21.4	3	1/2	6.3	115/60/1	3.7	Nema 5-15P	-10° F (~) 0° F	28.8 x 31.5 x 81.25	24 x 26.1 x 60.2	30 x 34 x 85	236 lbs.	269 lbs.
C-2FG-HC	2	43.2	6	3/4+	8.6	115/60/1	6.2	Nema 5-15P	-10° F (~) 0° F	51.75 x 31.5 x 81.25	47 x 26.1 x 60.2	53 x 35 x 85	353 lbs.	404 lbs.

\* Total height includes casters

**FOR COMMERCIAL USE ONLY**

NOTE: MIGALI® RESERVES THE RIGHT TO CHANGE SPECIFICATIONS WITHOUT NOTICE



TOLL FREE: 800.852.5292  
WEB: www.migali.com



# DIMENSIONAL DRAWINGS

C-1FG-HC

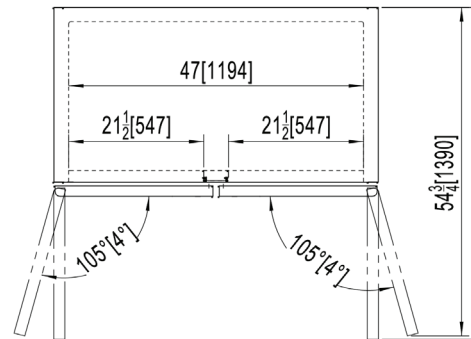
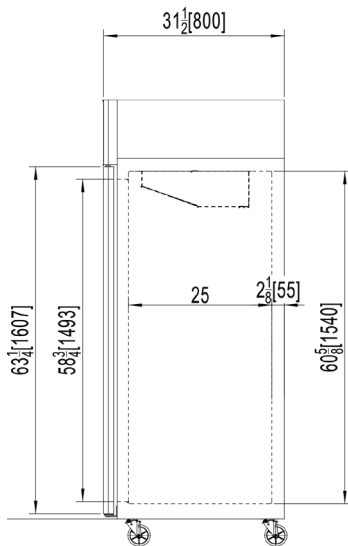
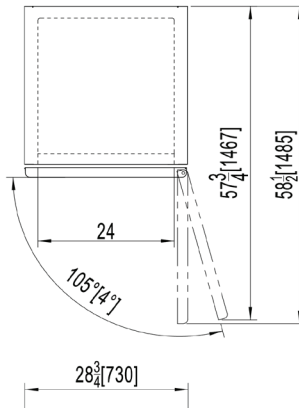
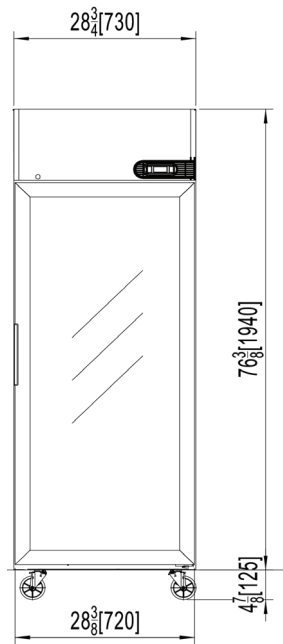

SIDE VIEW (1 & 2) DOOR MODELS



MIGALI® REMAINS AN AMERICAN FAMILY COMPANY SINCE 1955