



COMMERCIAL

Refrigeration Equipment 2-Half Door Full Height Freezer 27" Long

ITEM # _____

MODEL # _____

NAME # _____

SIS # _____

AIA # _____



738285 (KCHRI27R2HDF)

2-Half Door Full Height Freezer 27" Long

Short Form Specification

Item No. _____

2 half doors freezer with exterior back and bottom panels in galvanized steel, exterior side and top panels in 430 stainless steel; interior back, side, top and bottom panels in 304 stainless steel.

Control with cabinet temperature display. Self-closing and on-site reversible door feature lock and key.

R290 gas in the refrigeration circuit.

ETL Safety and Sanitation certifications.

3/5 Years warranty.

Main Features

- External temperature display.
- Removable gasket for easy cleaning operations.
- Fin & Tube Condenser improves performance in high temperature environments.
- Automatic Defrost Cooling System provides worry-free performance.
- Electronic Temperature Control, quick and simple to set, with control display for easy monitoring.
- Heavy duty Vinyl coated steel shelves.
- Cabinet completely insulated with high density polyurethane for low environmental impact.
- Bottom mounted cooling unit slides out for easy access and cleaning.

Construction

- Self-closing door with 90-degree stay-open feature.
- Heavy duty casters.
- Lockable door.
- Pre-wired heavy duty power cord.
- Heavy duty door hinges.
- Magnetic gasket removable without tools for easy cleaning.

Sustainability

- CFC and HCFC free, highly ecological refrigerant type: R290 (ecological gas in foam: cyclopentane). Hydrocarbon refrigerant gas R290 for the lowest environmental impact (GWP=3), to reduce green house and ozone depletion effects.
- Hydrocarbon refrigerant gas R290 for the lowest environmental impact (GWP=3) - CFC and HCFC free.
- High efficiency components to minimize the energy consumption still guaranteeing the highest performances.
- Interior LED light to save energy and for best internal visibility.

Optional Accessories

- shelf for 27" reach-in PNC 880590
- shelf clips PNC 880611

APPROVAL: _____

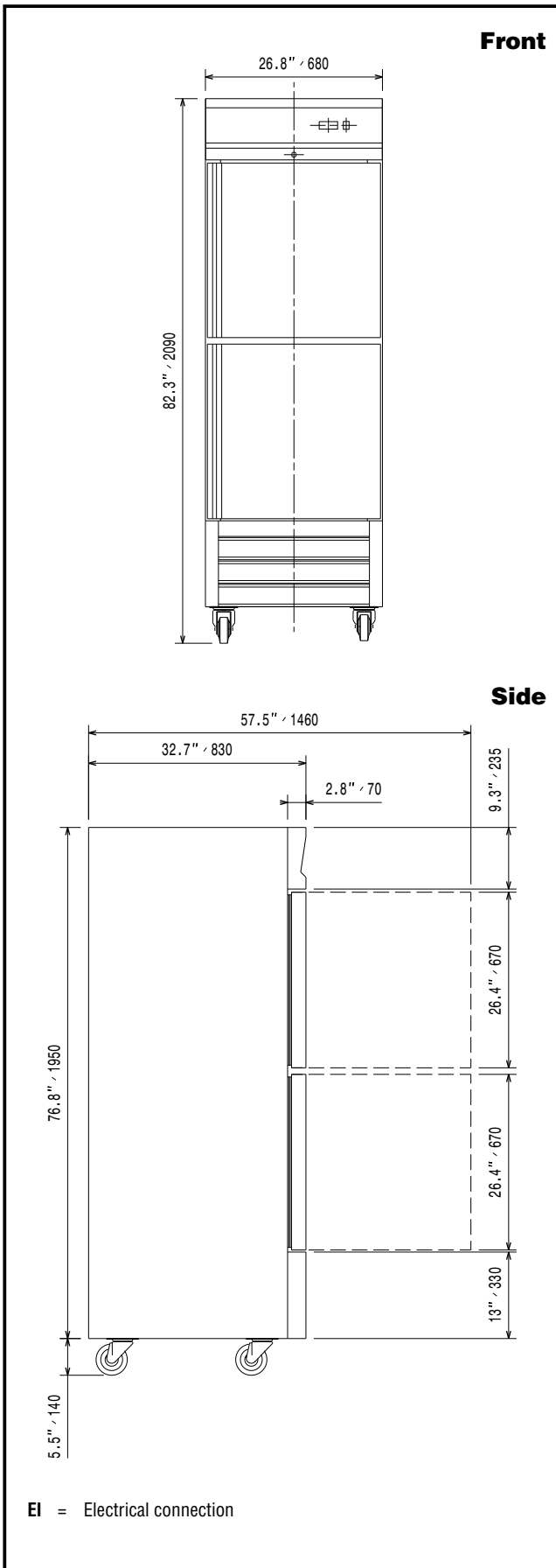

Electric

| | |
|------------------------|------------------|
| Supply voltage: | 115 V/1 ph/60 Hz |
| 738285 (KCHRI27R2HDF) | 0.8 kW |
| Electrical power, max: | USA NEMA 5-15P |
| Plug type: | |

Key Information:

| | |
|--------------------------------------|--|
| Capacity (Cu.Ft.) | 23 |
| Door hinges: | Right Side |
| External dimensions, Width: | 26 13/16" (681 mm) |
| External dimensions, Depth: | 31 7/8" (810 mm) |
| External dimensions, Height: | 82 1/4" (2090 mm) |
| Number and type of doors: | 2 Full |
| Internal Dimensions (depth): | 27 1/16" |
| Internal Dimensions (height): | 60 1/4" |
| Internal Dimensions (width): | 24 7/16" |
| Shipping height: | 84 5/8" (2150 mm) |
| Shipping weight: | 331 lbs (150 kg) |
| Shipping volume: | 49.91 ft ³ (1.41 m ³) |
| Number and type of grids (included): | 3 - Vinyl-Coated Steel |
| Type of external material: | 430 AISI |
| Type of internal material: | 304 AISI |
| Warranty: | 3 / 5 years |

Refrigeration Data

| | |
|-----------------------------|--------------|
| Compressor Horsepower: | 1/4 |
| Operating temperature min.: | -7.6 °F |
| Operating temperature max.: | -4 °F |
| Condenser type: | Fin & tube |
| Defrost type: | Auto Defrost |

Sustainability

| | |
|----------------------|--------|
| Current consumption: | 8 Amps |
| Refrigerant type: | R290 |
| Refrigerant weight: | 110 g |