



# REFRIGERATION

SERVING THE FOOD INDUSTRY SINCE 1951

## FLOOR MODEL REFRIGERATED DISPLAY CASES - 18 CU.FT CAPACITY

Item: 50077  
Model: RS-CN-0120-B

Item: 50079  
Model: RS-CN-0120-S

These Omcan's refrigeration units are the perfect blend of reliable and visually appealing. Keep your products fresh and in clear view of your customers with these floor model refrigerated display cases. These units give you a spacious 18 cu.ft of capacity. Bring these to your supermarket, convenience store or deli to help with impulse sales. The design will suit many establishments and keep up with all the demands of day-to-day service.



**WARRANTY**  
PARTS AND LABOR



NEMA  
5 - 15  
125 VAC / 15 AMP



Authorized Dealer

# REFRIGERATION

## FLOOR MODEL REFRIGERATED DISPLAY CASES - 18 CU.FT CAPACITY

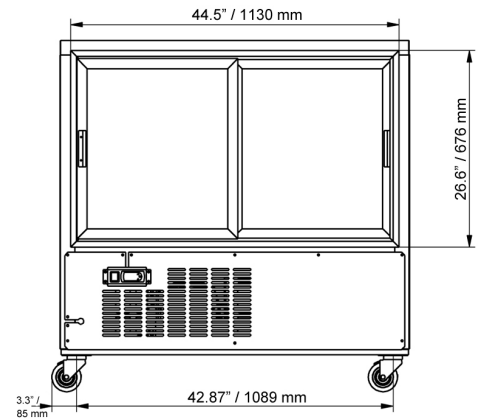
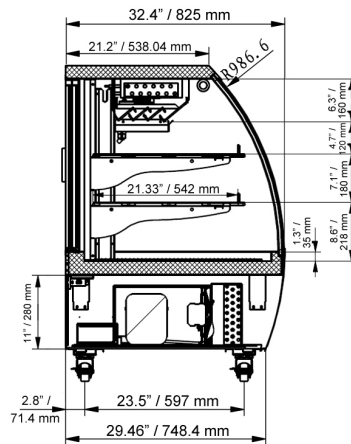
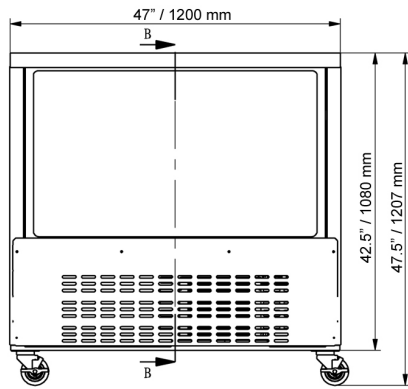

### Features:

- Interior: Aluminum liner with stainless steel floor
- Exterior: Black coated steel for item 50077 and stainless steel for item 50079
- Attractive curved glass with rear sliding glass doors
- Rounded corner design inside of the cabinet makes storage room easy to clean
- Temperatures range: 32° - 43° (0° - 6°)
- Removable installation board for easy cleaning and service
- Shelves: Adjustable heavy-duty PVC coated shelves
- LED interior lighting
- Gravity coil refrigeration system to avoid drying up and preservation of food products

### TECHNICAL SPECIFICATION

| ITEM NUMBER          | 50077                                   | 50079   |
|----------------------|---|---|
| MODEL                | RS-CN-0120-B                            | RS-CN-0120-S                                      |
| DESCRIPTION          | Black floor model refrigerated showcase | Stainless steel floor model refrigerated showcase |
| TEMPERATURE RANGE    | 0 - 6°C/ 32 - 43°F                      |   |
| POWER                | 1/4+                                    |   |
| ELECTRICAL           | 115V/60Hz/1Ph                           |   |
| AMPS                 | 2.6                                     |   |
| CAPACITY             | 508L/ 18 cu.ft                          |   |
| REFRIGERANT          | R290                                    |   |
| NET DIMENSIONS (WDH) | 47" x 32.5" x 43"/ 1200 x 825 x 1089 mm |   |
| GROSS DIMENSIONS     | 52" x 37" x 49"/ 1320 x 940 x 1240 mm   |   |
| NET WEIGHT           | 319 lbs/ 145 kgs                        |   |
| GROSS WEIGHT         | 429 lbs/ 195 kgs                        |   |
| CERTIFICATIONS       | cETLus / ETL Sanitation                 |   |

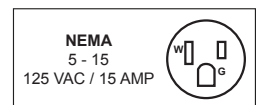

### OMCAN INC.

Telephone: 1-800-465-0234  
 Fax: (905) 607-0234  
 Email: sales@omcan.com  
 Website: www.omcan.com



Follow us to keep up to date with the latest news and offers

