



## *Reach In Bottle Coolers*

*Models BB-CN-0005-HC, 0014-HC, 0017-HC, 0026-HC  
Items 50038, 50039, 50040, 50041*

## *Instruction Manual*



*Revised - 09/28/2017*



Toll Free: 1-800-465-0234  
Fax: 905-607-0234  
Email: [service@omcan.com](mailto:service@omcan.com)  
[www.omcan.com](http://www.omcan.com)

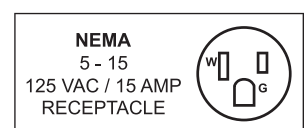

# ***Table of Contents***

Model BB-CN-0005-HC / Model BB-CN-0014-HC  
Model BB-CN-0017-HC / Model BB-CN-0026-HC

---

<b>Section</b>	<b>Page</b>
General Information -----	3 - 4
Safety and Warranty -----	4 - 5
Technical Specifications -----	6
Installation / Operation -----	6 - 8
Maintenance -----	8 - 9
Troubleshooting -----	9 - 10
Parts Breakdown -----	11 - 18
Electrical Schematics -----	19 - 22
Warranty Registration -----	23



# General Information

---

Omcan Manufacturing and Distributing Company Inc., Food Machinery of America, Inc. dba Omcan and Omcan Inc. are not responsible for any harm or injury caused due to any person's improper or negligent use of this equipment. The product shall only be operated by someone over the age of 18, of sound mind, and not under the influence of any drugs or alcohol, who has been trained in the correct operation of this machine, and is wearing authorized, proper safety clothing. Any modification to the machine voids any warranty, and may cause harm to individuals using the machine or in the vicinity of the machine while in operation.

## CHECK PACKAGE UPON ARRIVAL

Upon receipt of an Omcan shipment please inspect for external damage. If no damage is evident on the external packaging, open carton to ensure all ordered items are within the box, and there is no concealed damage to the machine. If the package has suffered rough handling, bumps or damage (visible or concealed), please note it on the bill of lading before accepting the delivery and contact Omcan within 24 hours, so we may initiate a claim with the carrier. A detailed report on the extent of the damage caused to the machine must be filled out within three days, from the delivery date shown in the shipping documents. Omcan has no recourse for damaged products that were shipped collect or third party.

**Before operating any equipment, always read and familiarize yourself with all operation and safety instructions.**

Omcan would like to thank you for purchasing this machine. It's of the utmost importance to save these instructions for future reference. Also save the original box and packaging for shipping the equipment if servicing or returning of the machine is required.

---

Omcan Fabrication et distribution Compañie Limité et Food Machinery d'Amérique, dba Omcan et Omcan Inc. ne sont pas responsables de tout dommage ou blessure causé du fait que toute personne ait utilisé cet équipement de façon irrégulière. Le produit ne doit être exploité que par quelqu'un de plus de 18 ans, saine d'esprit, et pas sous l'influence d'une drogue ou d'alcool, qui a été formé pour utiliser cette machine correctement, et est vêtu de vêtements de sécurité approprié. Toute modification de la machine annule toute garantie, et peut causer un préjudice à des personnes utilisant la machine ou des personnes à proximité de la machine pendant son fonctionnement.

## VÉRIFIEZ LE COLIS DÈS RÉCEPTION

Dès réception d'une expédition d'Omcan veuillez inspecter pour dommages externes. Si aucun dommage n'est visible sur l'emballage externe, ouvrez le carton afin de s'assurer que tous les éléments commandés sont dans la boîte, et il n'y a aucun dommage dissimulé à la machine. Si le colis n'a subi aucune mauvaises manipulations, de bosses ou de dommages (visible ou cachée), notez-le sur le bond de livraison avant d'accepter la livraison et contactez Omcan dans les 24 heures qui suivent, pour que nous puissions engager une réclamation auprès du transporteur. Un rapport détaillé sur l'étendue des dommages causés à la machine doit être rempli dans un délai de trois jours, à compter de la date de livraison indiquée dans les documents d'expédition. Omcan n'a aucun droit de recours pour les produits endommagés qui ont été expédiés ou cueilli par un tiers transporteur.

# ***General Information***

---

**Avant d'utiliser n'importe quel équipement, toujours lire et vous familiariser avec toutes les opérations et les consignes de sécurité.**

**Omcan voudrais vous remercier d'avoir choisi cette machine. Il est primordial de conserver ces instructions pour une référence ultérieure. Également conservez la boîte originale et l'emballage pour l'expédition de l'équipement si l'entretien ou le retour de la machine est nécessaire.**

-----  
**Omcan Empresa De Fabricacion Y Distribucion Inc. Y Maquinaria De Alimentos De America, Inc. dba Omcan y Omcan Inc. no son responsables de ningun daño o perjuicio causado por cualquier persona inadecuada o el uso descuidado de este equipo. El producto solo podra ser operado por una persona mayor de 18 años, en su sano juicio y no bajo alguna influencia de droga o alcohol, y que este ha sido entrenado en el correcto funcionamiento de esta máquina, y ésta usando ropa apropiada y autorizada. Cualquier modificación a la máquina anula la garantía y puede causar daños a las personas usando la máquina mientras esta en el funcionamiento.**

## **REVISE EL PAQUETE A SU LLEGADA**

Tras la recepcion de un envio Omcan favor inspeccionar daños externos. Si no hay daños evidentes en el empaque exterior, Habra el carton para asegurarse que todos los articulos solicitados estén dentro de la caja y no encuentre daños ocultos en la máquina. Si el paquete ha sufrido un manejo de poco cuidado, golpes o daños (visible o oculto) por favor anote en la factura antes de aceptar la entrega y contacte Omcan dentro de las 24 horas, de modo que podamos iniciar una reclamación con la compañía. Un informe detallado sobre los daños causados a la máquina debe ser llenado en el plazo de tres días, desde la fecha de entrega que se muestra en los documentos de envío. Omcan no tiene ningun recurso por productos dañados que se enviaron a recoger por terceros.

**Antes de utilizar cualquier equipo, siempre lea y familiarizarse con todas las instrucciones de funcionamiento y seguridad.**

**Omcan le gustaría darle las gracias por la compra de esta máquina. Es de la mayor importancia para salvar estas instrucciones para futuras consultas. Además, guarda la caja original y el embalaje para el envío del equipo si servicio técnico o devolución de la máquina que se requiere.**

# ***Safety and Warranty***

---

**Please pay close attention to the safety notices in this section. Disregarding these notices may lead to serious injury and/or damage to the unit.**

## **ATTENTION**

- To minimize shock and fire hazards, be sure not to overload outlet. Please designate one outlet for your unit.

# ***Safety and Warranty***

---

- Do not use extension cords.
- Do not put your hands under the unit when the units is required to be moved.
- When the unit is not in use for a long period of time, please unplug the unit from the outlet.
- After unplugging the unit, wait at least 10 minutes before re-plugging it. Failure to do so could cause damage to the compressor.

## **UNPLUG CORD**

- To minimize shock and fire hazards, please do not plug or unplug the cord with wet hands.
- During maintenance and cleaning, please unplug the unit.

## **PROPER GROUNDING REQUIRED**

- To minimize shock and fire hazards, make sure that the unit is properly grounded.

## **PROHIBITION**

- Do not attempt to remove or repair any component unless instructed by factory.
- Make sure that the unit is not resting on or against the electrical cord and plug.
- To minimize personal injury, do not hang on the doors.
- Do not store any flammable and explosive gas or liquids inside the unit.
- Do not attempt to alter or tamper with the electrical cord.
- Do not set the desired temperature out of the recommended temperature range: (Ref: 32°F - 50°F).

## **1 YEAR PARTS AND LABOUR WARRANTY**

**Within the warranty period, contact Omcan Inc. at 1-800-465-0234 to schedule an Omcan authorized service technician to repair the equipment locally.**

**Unauthorized maintenance will void the warranty. Warranty covers electrical and part failures, not improper use.**

**Please see [www.omcan.com/warranty.html](http://www.omcan.com/warranty.html) for complete info.**

## **WARNING:**

The packaging components are classified as normal solid urban waste and can therefore be disposed of without difficulty.

**In any case, for suitable recycling, we suggest disposing of the products separately (differentiated waste) according to the current norms.**

**DO NOT DISCARD ANY PACKAGING MATERIALS IN THE ENVIRONMENT!**

# Technical Specifications

Model	BB-CN-0005-HC	BB-CN-0014-HC	BB-CN-0017-HC	BB-CN-0026-HC
Horsepower	1/6			1/4+
Net Volume	141 L / 5 cu. ft.	382 L / 13.5 cu. ft.	488 L / 17.23 cu. ft.	730 L / 25.8 cu. ft.
Temperature Range	0.5 - 3.3°C / 33 - 38°F			
Electrical	115V / 60Hz			
Amps	2.04A	2.28A	2.6A	4.2A
Refrigerant	R290			
Isolation Material	Cyclopentane			
Cooling System	Ventilated			
Defrosting	Automatic			
Dimensions (DWH)	28.5" x 26.5" x 34.25" 713 x 670 x 869mm	26.5" x 49.5" x 34.25" 713 x 1257 x 869mm	26.5" x 64.5" x 34.25" 713 x 1638 x 869mm	26.5" x 95" x 34.25" 713 x 2418 x 869mm
Interior Dimensions	23" x 21.25" x 26" 584 x 540 x 660mm	45" x 23" x 26" 1143 x 584 x 660mm	60" x 23" x 26" 1524 x 584 x 660mm	23" x 91.1" x 26" 584 x 2314 x 660mm
Weight	137 lbs. / 62 kgs.	181 lbs. / 82 kgs.	253 lbs. / 115 kgs.	386 lbs. / 175 kgs.
Packaging Dimensions	30.4" x 31.1" x 41.75" 772 x 790 x 1061mm	32.75" x 56" x 41.75" 832 x 1422 x 1060mm	32.75" x 70" x 41.75" 832 x 1778 x 1060mm	32" x 101" x 42" 813 x 2565 x 1067mm
Packaging Weight	180 lbs. / 82 kgs.	247 lbs. / 112 kgs.	308 lbs. / 140 kgs.	386 lbs. / 175.1 kgs.
Item Number	50038	50039	50040	50041

## Installation / Operation

### IMPORTANT!!!PLEASE READ BEFORE INSTALLATION

- If the unit has recently been transported. Please let unit stand still for a minimum of 24 hours before plugging it in.
- Make sure that the unit drops down to desired temperature before loading the unit with product.
- Make sure that there is proper ventilation around the unit in the area where it will operate.
- Make sure all accessories are installed(i.e. shelves, shelf clips, casters) before plugging the unit in.
- Please read through the Operation / Owners Manual in its entirety.

### CABINET LOCATION GUIDELINES

- Install the unit on strong and leveled surfaces.
  - Unit may make unpleasant noises if surface is uneven.



# Installation / Operation

---

- Unit may malfunction if surface is uneven.
- Install the unit in an indoor, well-ventilated area.
  - Unit performs more efficiently in a well-ventilated area.
  - For best performance, please maintain clearance of 6" on the back of the unit.
  - Outdoor use may cause decreased efficiency and damage to the unit.
- Avoid installation in a high humidity and/or dusty area.
  - Humidity could cause unit to rust and decrease efficiency of the unit.
  - Dust collected on condenser coil will cause unit to malfunction. Clean the condenser at least once a month with a brush or clean cloth.
- Select a location away from heat and moisture-generating equipment.
  - High ambient temperature will cause the compressor to overwork, leading to higher energy bills and gradual breakdown of the unit.

## **ELECTRICAL**

Please ensure that the required voltage of the compressor is being supplied at all times. Low or high voltage can detrimentally affect the refrigeration unit. All units should be plugged into a grounded and properly-sized electrical outlet with appropriate overcurrent protection. Please refer to the electrical requirement on the nameplate. Please make sure that your unit has its own dedicated outlet. Do not use an extension cord.

## **TEMPERATURE CONTROLS**

The temperature controls are factory-set to maintain an average temperature of 38°F in refrigeration. To maintain a different temperature, simply adjust the control knob located inside the unit. To decrease the temperature (colder), turn clockwise. To increase the temperature (warmer), turn counter-clockwise – see diagram.

## **LOADING PRODUCT**

The bin dividers have been installed at the factory for your convenience. Feel free to reposition the dividers as you see fit. To remove the bin dividers, simply push the divider towards the back wall until the front of the divider is removed from the positioning holes. To install, position the divider to the desired holes, making sure that the pressure spring is installed properly.

**PAY CLOSE ATTENTION TO THE LOAD LIMIT STICKERS LOCATED ON THE INTERIOR WALLS TO THE UNIT. DO NOT LOAD PRODUCT ABOVE THE LOAD LIMIT STICKERS OR ABOVE THE TOP CROSS BAR OF THE BIN DIVIDERS. LOADING PRODUCT ABOVE THE LOAD LIMIT STICKERS WILL HARM THE PERFORMANCE OF THE UNIT.**

# Installation / Operation

## CAUTION

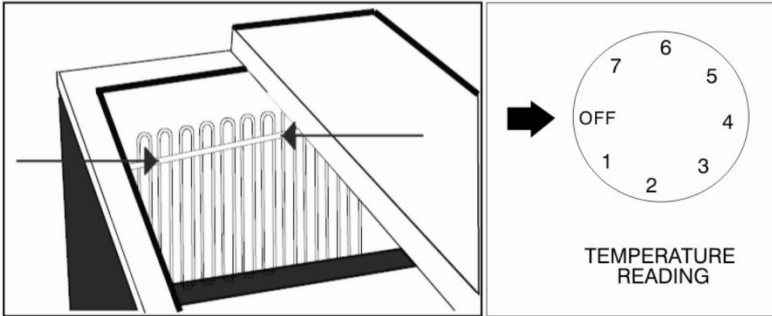

Setting the temperature control to the coldest setting may cause the Evaporator coil to freeze and ice up. This will eventually result in a warmer Cabinet temperature.

Temperature range from 7 (coldest) to 1 (warmest).

Do not load Product above the top crossbar. Doing so will harm the Refrigeration.

## MECHANICAL CONTROLLER INSTRUCTIONS

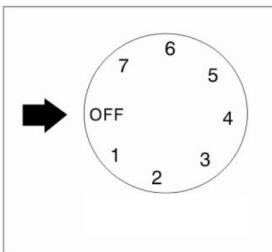

OFF: shut the compressor off

Temperature range from 7 (coldest) to 1 (warmest).

**CAUTION:** Setting the temperature control to the coldest setting may cause the evaporator coil to freeze and ice up. This will eventually result in a warmer cabinet temperature.

# Maintenance

## CLEANING THE CONDENSER COIL

- For efficient operation, it is important that the condenser surface be kept free of dust, dirt, and lint.
- We recommend cleaning the condenser coil and fins at least once per month.
- Clean with a commercial condenser coil cleaner, available from any kitchen equipment retailer. Brush the condenser fins from top to bottom, not side to side.
- After cleaning, straighten any bent condenser fins with a fin comb.

## CLEANING THE FAN BLADE AND MOTOR

- If necessary, clean the fan blades and motor with a soft cloth. If it is necessary to wash the fan blades, cover the fan motor to prevent moisture damage.

## CLEANING THE INTERIOR OF UNIT

- When cleaning the cabinet interior, use a solvent of warm water and mild soap.
- Do not use steel wool, caustic soap, abrasive cleaners, or bleach that may damage the stainless steel



# Maintenance

surface.

- Wash door gaskets on a regular basis, preferably weekly. Simply remove door gasket from the frame of the door, soak in warm water and soap for thirty (30) minutes, dry with soft cloth, and replace.
- Check door gaskets for proper seal after they are replaced.
- Periodically remove the shelves and pilasters from the unit and clean them with mild soap and warm water. To remove the pilasters, first remove the shelves and shelf brackets. Then, simply lift the pilaster up and out.

**WARNING: Disconnect power cord before cleaning any parts of the unit.**

# Troubleshooting

Before requesting any service on your unit, please check the following points. Please note that this guide serve only as a reference for solutions to common problems.

PROBLEM	POSSIBLE CAUSE	CORRECTIVE ACTION
Compressor not running.	Fuse blown or circuit breaker tripped.	Replace fuse or reset circuit breaker.
	Power cord unplugged.	Plug in power cord.
	Thermostat set too high.	Set thermostat to lower Temperature.
	Cabinet in defrost cycle.	Wait for defrost cycle to finish.
Condensing unit runs for long periods of time.	Excessive amount of warm product Placed in cabinet.	Allow adequate time for Product to cool down.
	Prolonged door opening or door ajar.	Ensure doors are closed when not in use. Avoid opening doors for long periods of time.
	Door gasket(s) not sealing properly.	Ensure gaskets are snapped in Completely. Remove gasket and Wash with soap and water. Check condition of gasket and Replace if necessary.
	Dirty condenser coil.	Clean the condenser coil.
	Evaporator coil iced over.	Unplug unit and allow coil to defrost. Make sure thermostat is not set too cold. Ensure that door gasket(s) are sealing properly.

# Troubleshooting

Cabinet Temperature Is too warm.	Thermostat set too warm.	Set thermostat to lower Temperature.
	Blocking air flow.	Re-arrange product to allow for Proper air flow. Make sure there Is at least four inches of clearance from evaporator.
	Excessive amount of warm product Placed in cabinet.	Allow adequate time for product to cool down.
	Fuse blown or circuit breaker tripped.	Replace fuse or reset circuit breaker.
	Dirty condenser coil.	Clean the condenser coil.
	Prolonged door opening or door ajar.	Ensure doors are closed when not in use. Avoid opening doors for long periods of time.
	Evaporator coil iced over.	(See above)
Cabinet is noisy.	Loose part(s).	Locate and tighten loose part(s).
	Tubing vibration.	Ensure tubing is free from contact with other tubing or components.

***For service call 1-800-465-0234.***

## REFERENCE

Item Number	Model Number	Description	Manufacturer Model Number
50038	BB-CN-0005-HC	Cooler Back Bar 5 cu ft Reach In 115V/60/1 ETL cETLus INTERTEK	JBC-25-HC
50039	BB-CN-0014-HC	Cooler Back Bar 13.5 cu ft Reach In 115V/60/1 ETL cETLus INTERTEK	JBC-50-HC
50040	BB-CN-0017-HC	Cooler Back Bar 17.2 cu ft Reach In 115V/60/1 ETL cETLus INTERTEK	JBC-65-HC
50041	BB-CN-0026-HC	Cooler Back Bar 25.8 cu ft Reach In 115V/60/1 ETL cETLus INTERTEK	JBC-95-HC

# Parts Breakdown

Model **BB-CN-0005-HC** 50038

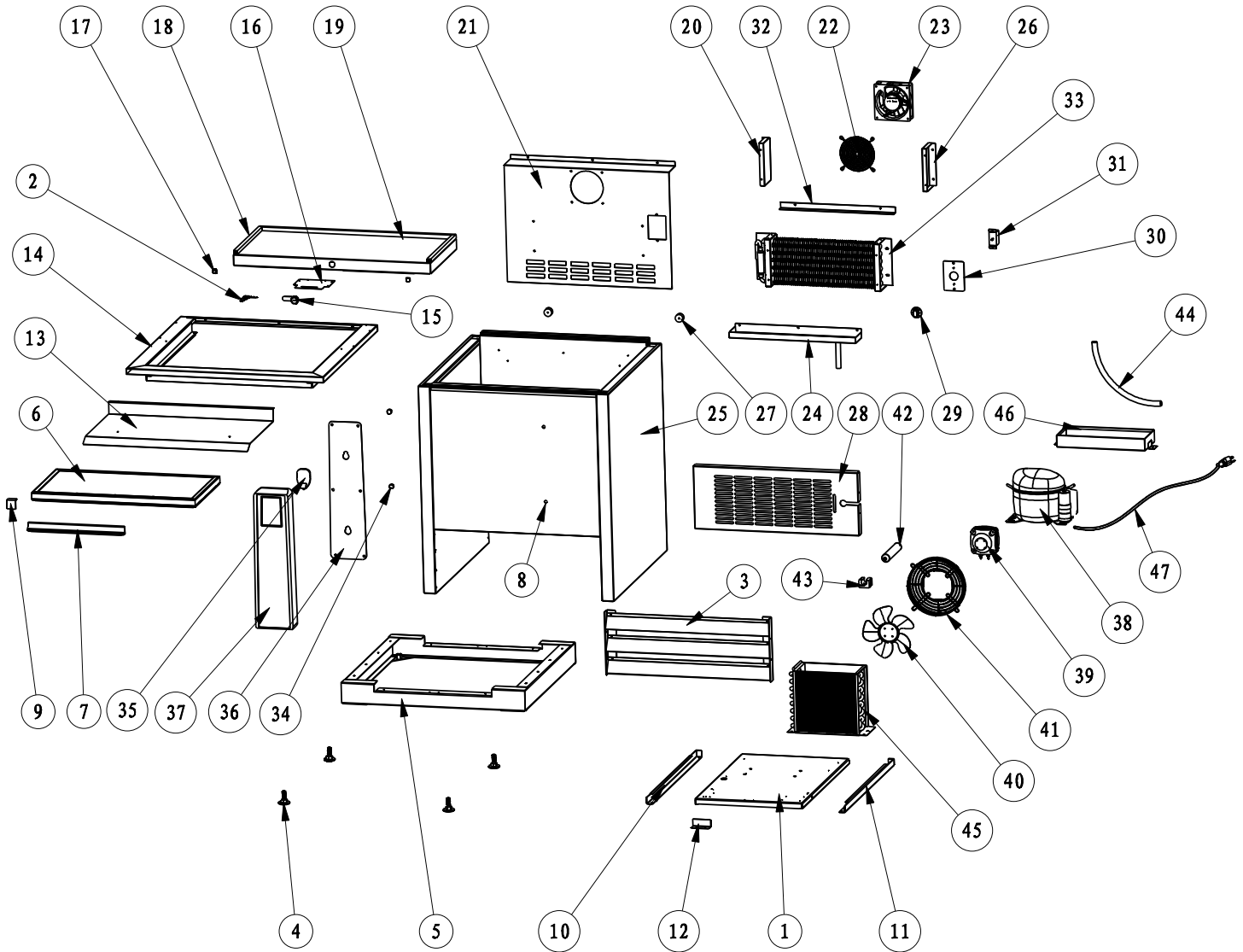

# Parts Breakdown

## Model BB-CN-0005-HC 50038

Item No.	Description	Position	Item No.	Description	Position	Item No.	Description	Position
37743	Compressor Mounting Plate for JBC-25-HC	1	37764	Terminal Cover of Stopping Bar for JBC-25-HC	17	72000	Evaporator for JBC-25-HC	33
71986	Key for JBC-25-HC	2	71993	Stopping Bar for JBC-25-HC	18	37785	Screw of Collecting Box for JBC-25-HC	34
71987	Front Shutter for JBC-25-HC	3	71994	Top Board for JBC-25-HC	19	37784	Bottle Opener for JBC-25-HC	35
37747	Adjustable Feet for JBC-25-HC	4	37769	Left Plate of Evaporator Cover for JBC-25-HC	20	37786	Inner Plate of Collecting Box for JBC-25-HC	36
71988	Bottom Plate of Cabinet for JBC-25-HC	5	71995	Evaporator Cover for JBC-25-HC	21	37787	Collecting Box of Bottle Cap for JBC-25-HC	37
37749	Door for JBC-25-HC	6	37772	Evaporator Fan Cover for JBC-25-HC	22	72001	Compressor for JBC-25-HC	38
37751	Door Handle for JBC-25-HC	7	37773	Evaporator Fan for JBC-25-HC	23	26776	Condenser Fan Motor for JBC-25-HC	39
37753	Rivet for JBC-25-HC	8	71996	Interior Water Tray for JBC-25-HC	24	28254	Condenser Fan Blade for JBC-25-HC	40
37754	Limited Block for JBC-25-HC	9	71997	Cabinet for JBC-25-HC	25	28256	Condenser Fan Cover for JBC-25-HC	41
71989	Left Track of Compressor Mounting Plate for JBC-25-HC	10	37778	Right Plate of Evaporator Cover for JBC-25-HC	26	37791	Filter D25x140 for JBC-25-HC	42
71990	Right Track of Compressor Mounting Plate for JBC-25-HC	11	37779	Stand Off Bracket for JBC-25-HC	27	26188	Filter Base D25 for JBC-25-HC	43
28311	Stop Block of Compressor Mounting Plate for JBC-25-HC	12	71998	Rear Shutter for JBC-25-HC	28	37792	Drain Hose for JBC-25-HC	44
71991	Lower Plate of Top Board for JBC-25-HC	13	27092	Knob of Temperature Controller for JBC-25-HC	29	26775	Condenser for JBC-25-HC	45
71992	Frame of Top Board for JBC-25-HC	14	37693	Temperature Control Panel for JBC-25-HC	30	37794	Exterior Water Tray for JBC-25-HC	46
37762	Door Lock for JBC-25-HC	15	27090	Mechanical Thermostat for JBC-25-HC	31	37795	Power Cord for JBC-25-HC	47
37763	Plate of Lock for JBC-25-HC	16	71999	Left Plate of Evaporator Cover for JBC-25-HC	32			

# Parts Breakdown

Model BB-CN-0014-HC 50039

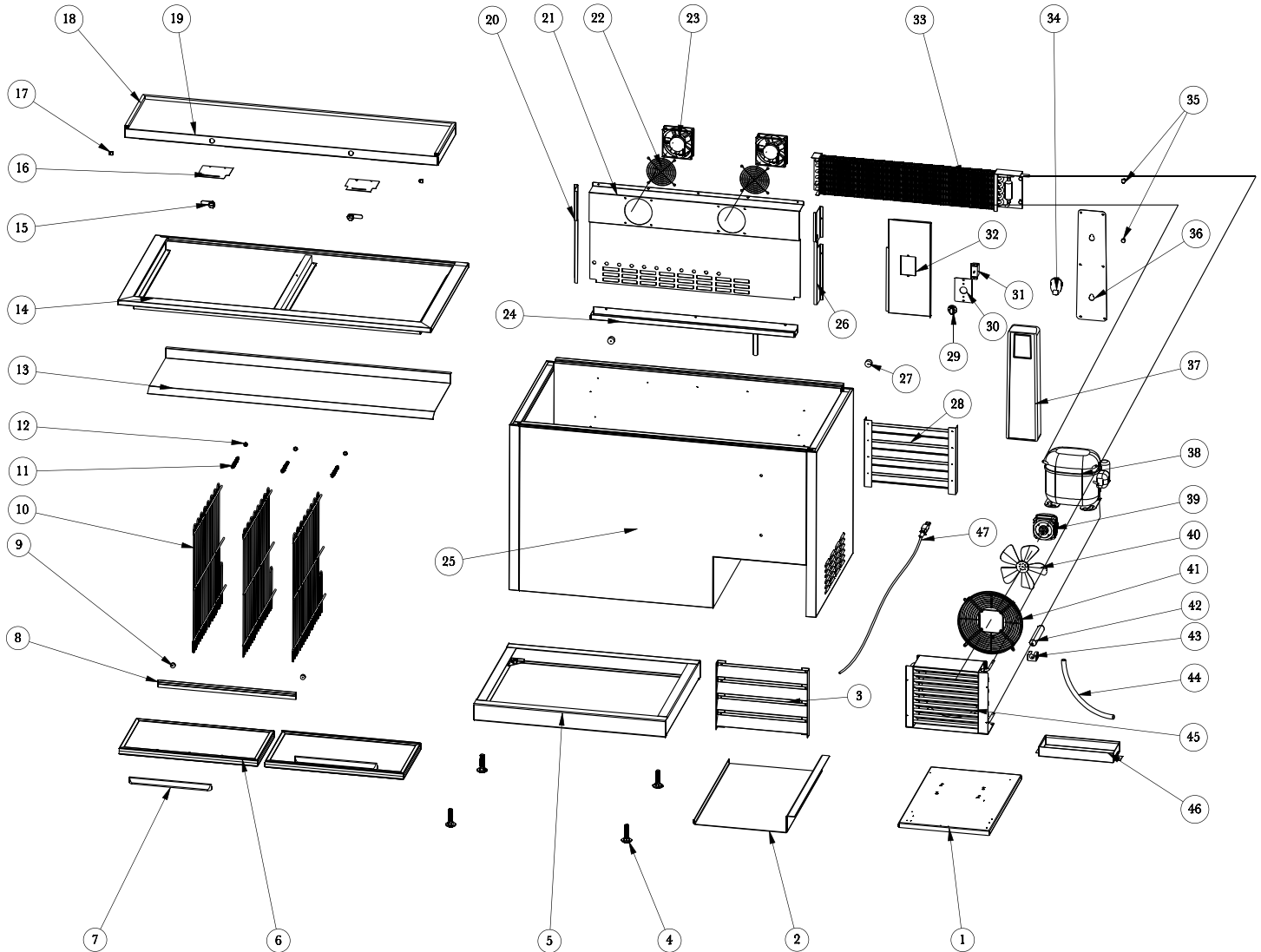

# Parts Breakdown

## Model BB-CN-0014-HC 50039

Item No.	Description	Position	Item No.	Description	Position	Item No.	Description	Position
37743	Compressor Mounting Plate for JBC-50-HC	01	37762	Door Lock for JBC-50-HC	15	37781	Controller Mounting Plate for JBC-50-HC	32
37745	Bottom Cover of Machine Room for JBC-50-HC	02	37763	Plate of Lock for JBC-50-HC	16	37782	Evaporator for JBC-50-HC	33
37746	Front Shutter for JBC-50-HC	03	37764	Terminal Cover of Stopping Bar for JBC-50-HC	17	37784	Bottle Opener for JBC-50-HC	34
37747	Adjustable Feet for JBC-50-HC	04	37765	Stopping Bar for JBC-50-HC	18	37785	Screw of Collecting Box for JBC-50-HC	35
37748	Bottom Plate of Cabinet for JBC-50-HC	05	37767	Top Board for JBC-50-HC	19	37786	Inner Plate of Collecting Box for JBC-50-HC	36
37749	Door for JBC-50-HC	06	37769	Left Plate of Evaporator Cover for JBC-50-HC	20	37787	Collecting Box of Bottle Cap for JBC-50-HC	37
37751	Door Handle for JBC-50-HC	07	37770	Evaporator Cover for JBC-50-HC	21	37788	Condenser Fan Motor for JBC-50-HC	39
37752	Door Seal for JBC-50-HC	08	37772	Evaporator Fan Cover for JBC-50-HC	22	37789	Condenser Fan Blade for JBC-50-HC	40
37754	Limited Block for JBC-50-HC	09	37773	Evaporator Fan for JBC-50-HC	23	37790	Condenser Fan Cover for JBC-50-HC	41
37755	Shelf for JBC-50-HC	10	37774	Interior Water Tray for JBC-50-HC	24	37791	Dry Filter for JBC-50-HC	42
37756	Spring of Shelf for JBC-50-HC	11	37776	Cabinet for JBC-50-HC	25	37792	Drain Hose for JBC-50-HC	44
37757	Cover of Shelf for JBC-50-HC	12	37778	Right Plate of Evaporator Cover for JBC-50-HC	26	37793	Condenser for JBC-50-HC	45
37758	Lower Plate of Top Board for JBC-50-HC	13	37779	Stand Off Bracket for JBC-50-HC	27	37794	Exterior Water Tray for JBC-50-HC	46
37760	Frame of Top Board for JBC-50-HC	14	37780	Rear Shutter for JBC-50-HC	28	37795	Power Cord for JBC-50-HC	47

# Parts Breakdown

Model **BB-CN-0017-HC** 50040

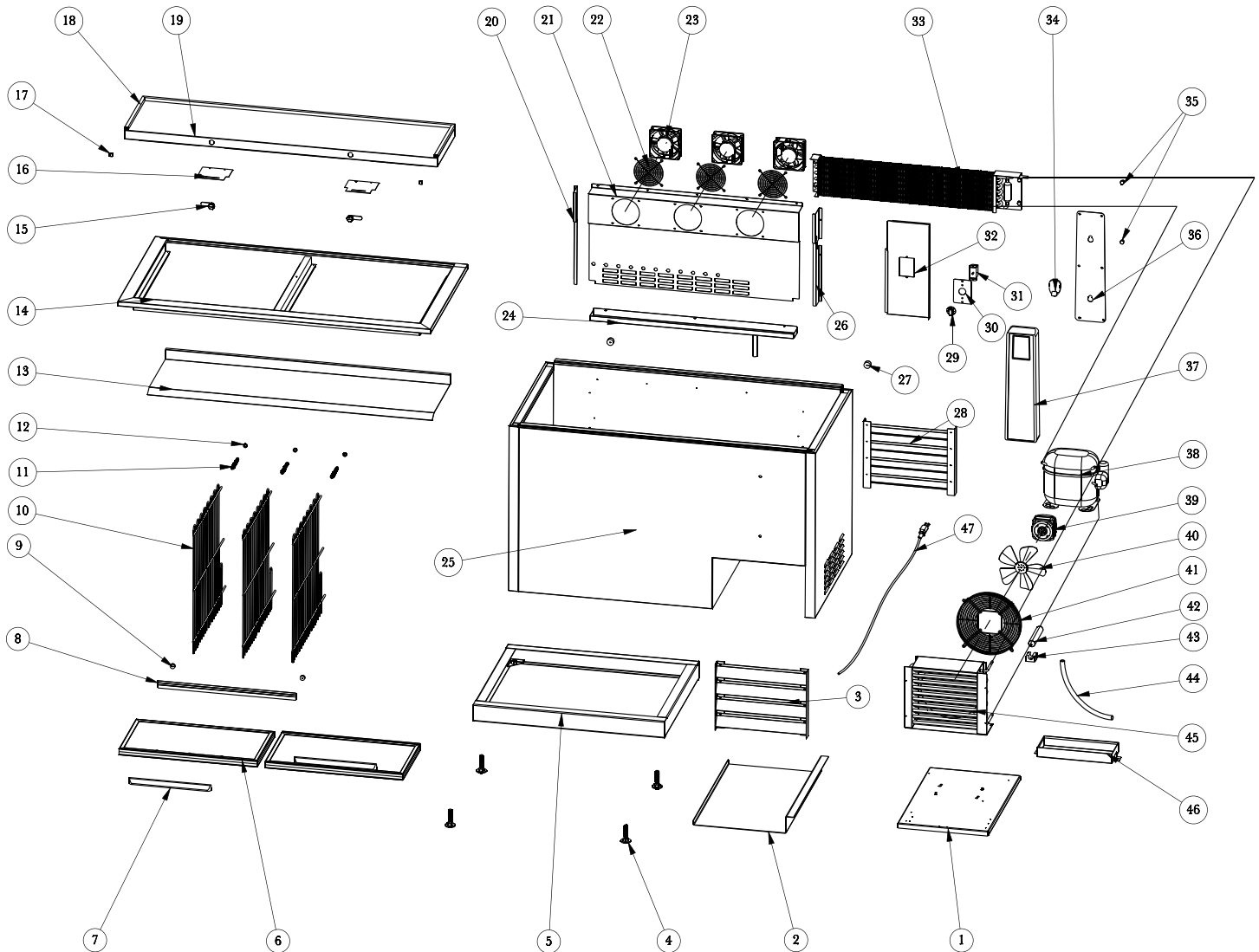

# Parts Breakdown

## Model BB-CN-0017-HC 50040

Item No.	Description	Position	Item No.	Description	Position	Item No.	Description	Position
37744	Compressor Mounting Plate for JBC-65-HC	01	37762	Door Lock for JBC-65-HC	15	37781	Controller Mounting Plate for JBC-65-HC	32
37745	Bottom Cover of Machine Room for JBC-65-HC	02	37763	Plate of Lock for JBC-65-HC	16	37783	Evaporator for JBC-65-HC	33
37746	Front Shutter for JBC-65-HC	03	37764	Terminal Cover of Stopping Bar for JBC-65-HC	17	37784	Bottle Opener for JBC-65-HC	34
37747	Adjustable Feet for JBC-65-HC	04	37766	Stopping Bar for JBC-65-HC	18	37785	Screw of Collecting Box for JBC-65-HC	35
37748	Bottom Plate of Cabinet for JBC-65-HC	05	37768	Top Board for JBC-65-HC	19	37786	Inner Plate of Collecting Box for JBC-65-HC	36
37750	Door for JBC-65-HC	06	37769	Left Plate of Evaporator Cover for JBC-65-HC	20	37787	Collecting Box of Bottle Cap for JBC-65-HC	37
37751	Door Handle for JBC-65-HC	07	37771	Evaporator Cover for JBC-65-HC	21	37788	Condenser Fan Motor for JBC-65-HC	39
37753	Door Seal for JBC-65-HC	08	37772	Evaporator Fan Cover for JBC-65-HC	22	37789	Condenser Fan Blade for JBC-65-HC	40
37754	Limited Block for JBC-65-HC	09	37773	Evaporator Fan for JBC-65-HC	23	37790	Condenser Fan Cover for JBC-65-HC	41
37755	Shelf for JBC-65-HC	10	37775	Interior Water Tray for JBC-65-HC	24	37791	Dry Filter for JBC-65-HC	42
37756	Spring of Shelf for JBC-65-HC	11	37777	Cabinet for JBC-65-HC	25	37792	Drain Hose for JBC-65-HC	44
37757	Cover of Shelf for JBC-65-HC	12	37778	Right Plate of Evaporator Cover for JBC-65-HC	26	37793	Condenser for JBC-65-HC	45
37759	Lower Plate of Top Board for JBC-65-HC	13	37779	Stand Off Bracket for JBC-65-HC	27	37794	Exterior Water Tray for JBC-65-HC	46
37761	Frame of Top Board for JBC-65-HC	14	37780	Rear Shutter for JBC-65-HC	28	37795	Power Cord for JBC-65-HC	47



# Parts Breakdown

Model BB-CN-0026-HC 50041

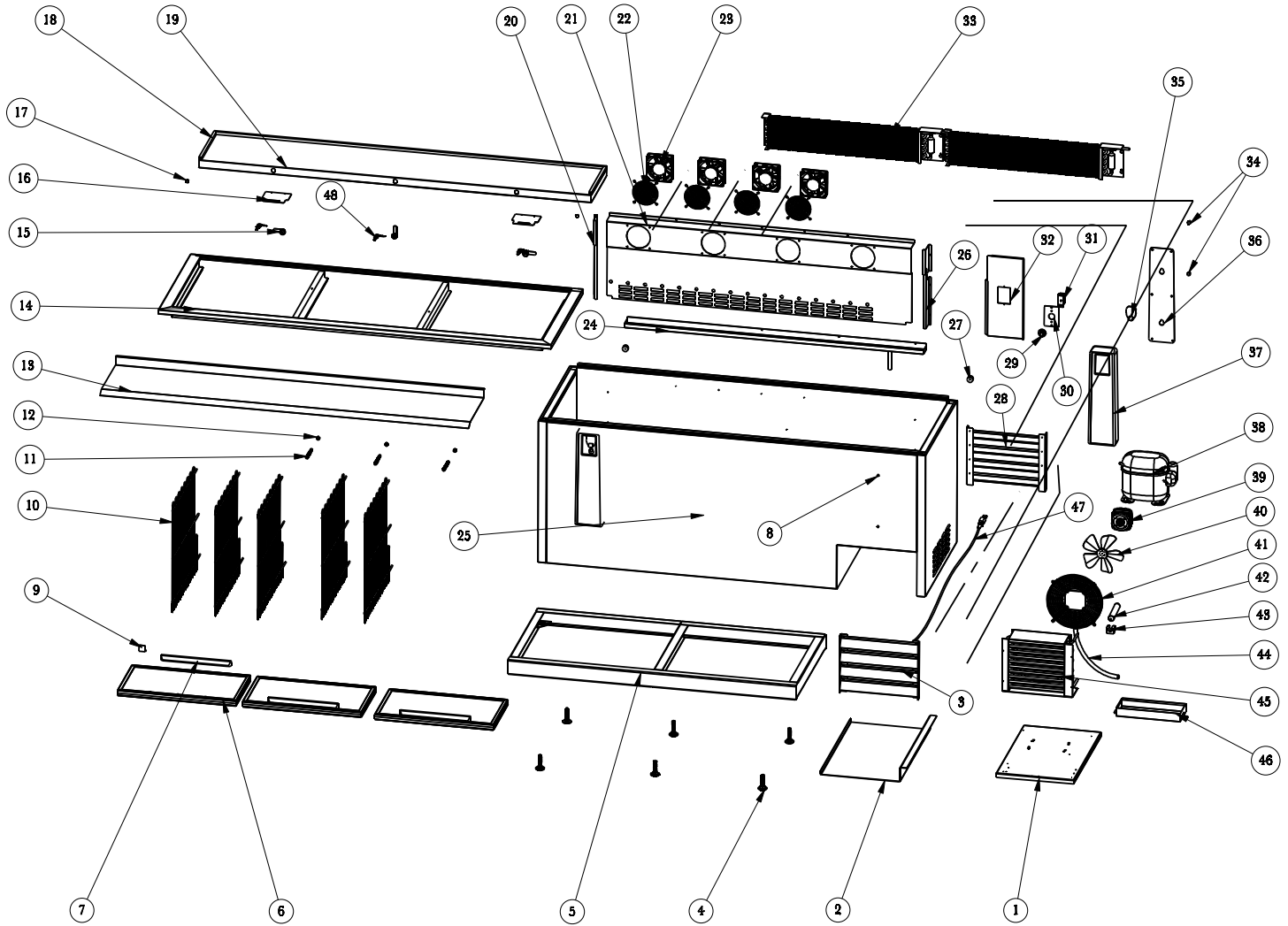

# Parts Breakdown

## Model BB-CN-0026-HC 50041

Item No.	Description	Position	Item No.	Description	Position	Item No.	Description	Position
37743	Compressor Mounting Plate for JBC-95-HC	1	37764	Terminal Cover of Stopping Bar for JBC-95-HC	17	72010	Evaporator for JBC-95-HC	33
37745	Bottom Cover of Machine Room for JBC-95-HC	2	72005	Stopping Bar for JBC-95-HC	18	37785	Screw of Collecting Box for JBC-95-HC	34
37746	Front Shutter for JBC-95-HC	3	72006	Top Board for JBC-95-HC	19	37784	Bottle Opener for JBC-95-HC	35
37747	Adjustable Feet for JBC-95-HC	4	37769	Left Plate of Evaporator Cover for JBC-95-HC	20	37786	Inner Plate of Collecting Box for JBC-95-HC	36
72002	Bottom Plate of Cabinet for JBC-95-HC	5	72007	Evaporator Cover for JBC-95-HC	21	37787	Collecting Box of Bottle Cap for JBC-95-HC	37
37750	Door for JBC-95-HC	6	37772	Evaporator Fan Cover for JBC-95-HC	22	26280	Compressor for JBC-95-HC	38
37751	Door Handle for JBC-95-HC	7	37773	Evaporator Fan for JBC-95-HC	23	37788	Condenser Fan Motor for JBC-95-HC	39
37753	Rivet for JBC-95-HC	8	72008	Interior Water Tray for JBC-95-HC	24	37789	Condenser Fan Blade for JBC-95-HC	40
37754	Limited Block for JBC-95-HC	9	72009	Cabinet for JBC-95-HC	25	37790	Condenser Fan Cover for JBC-95-HC	41
37755	Shelf for JBC-95-HC	10	37778	Right Plate of Evaporator Cover for JBC-95-HC	26	37791	Filter D25x140 for JBC-95-HC	42
37756	Spring of Shelf for JBC-95-HC	11	37779	Stand Off Bracket for JBC-95-HC	27	26188	Filter Base D25 for JBC-95-HC	43
37757	Cover of Shelf for JBC-95-HC	12	37780	Rear Shutter for JBC-95-HC	28	37792	Drain Hose for JBC-95-HC	44
72003	Lower Plate of Top Board for JBC-95-HC	13	27092	Knob of Temperature Controller for JBC-95-HC	29	72011	Condenser for JBC-95-HC	45
72004	Frame of Top Board for JBC-95-HC	14	37693	Temperature Control Panel for JBC-95-HC	30	37794	Exterior Water Tray for JBC-95-HC	46
37762	Door Lock for JBC-95-HC	15	27090	Mechanical Thermostat for JBC-95-HC	31	37795	Power Cord for JBC-95-HC	47
37763	Plate of Lock for JBC-95-HC	16	37781	Controller Mounting Plate for JBC-95-HC	32	72012	Door Key for JBC-95-HC	48

# Electrical Schematics

Model **BB-CN-0005-HC** 50038

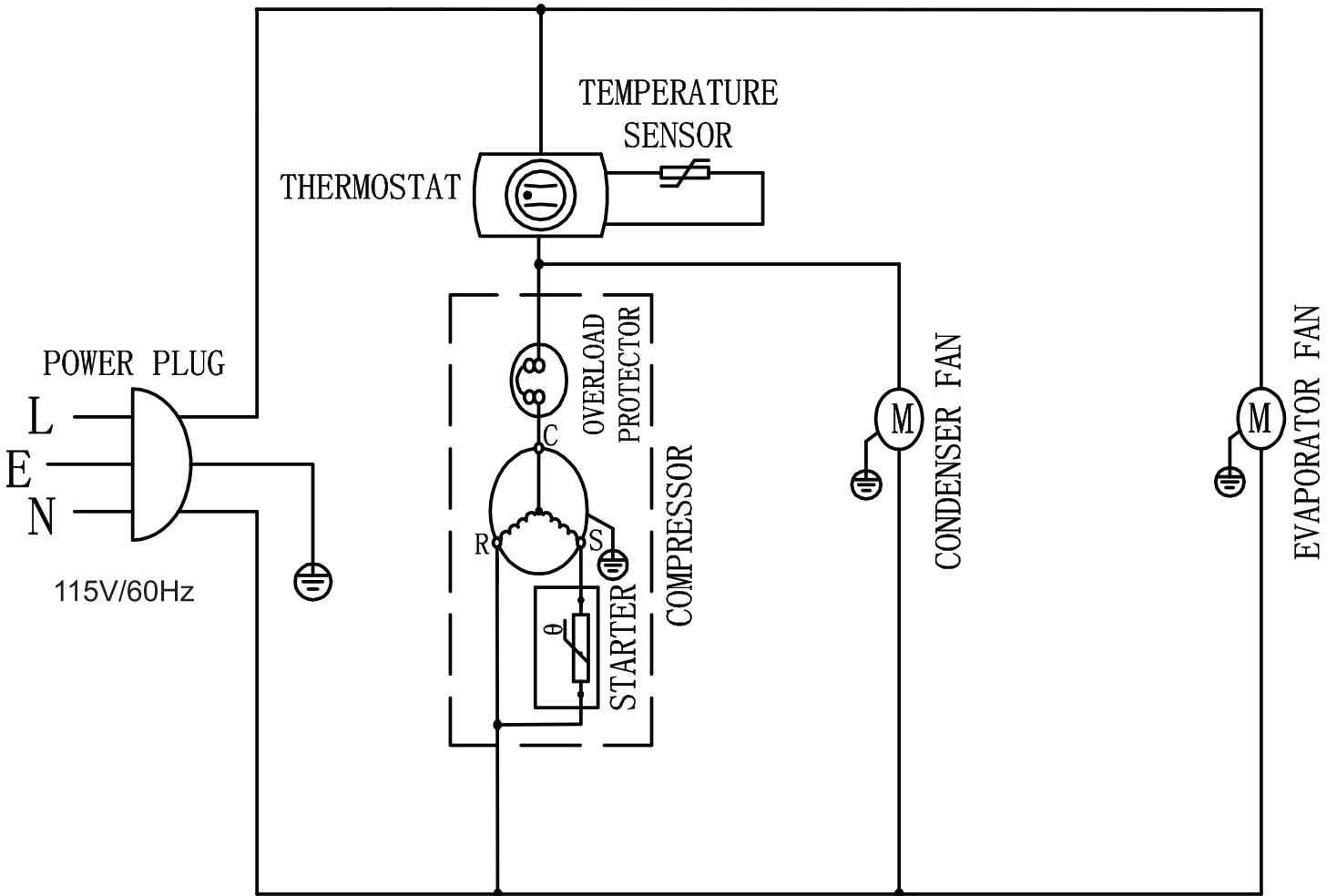

# Electrical Schematics

Model BB-CN-0014-HC 50039

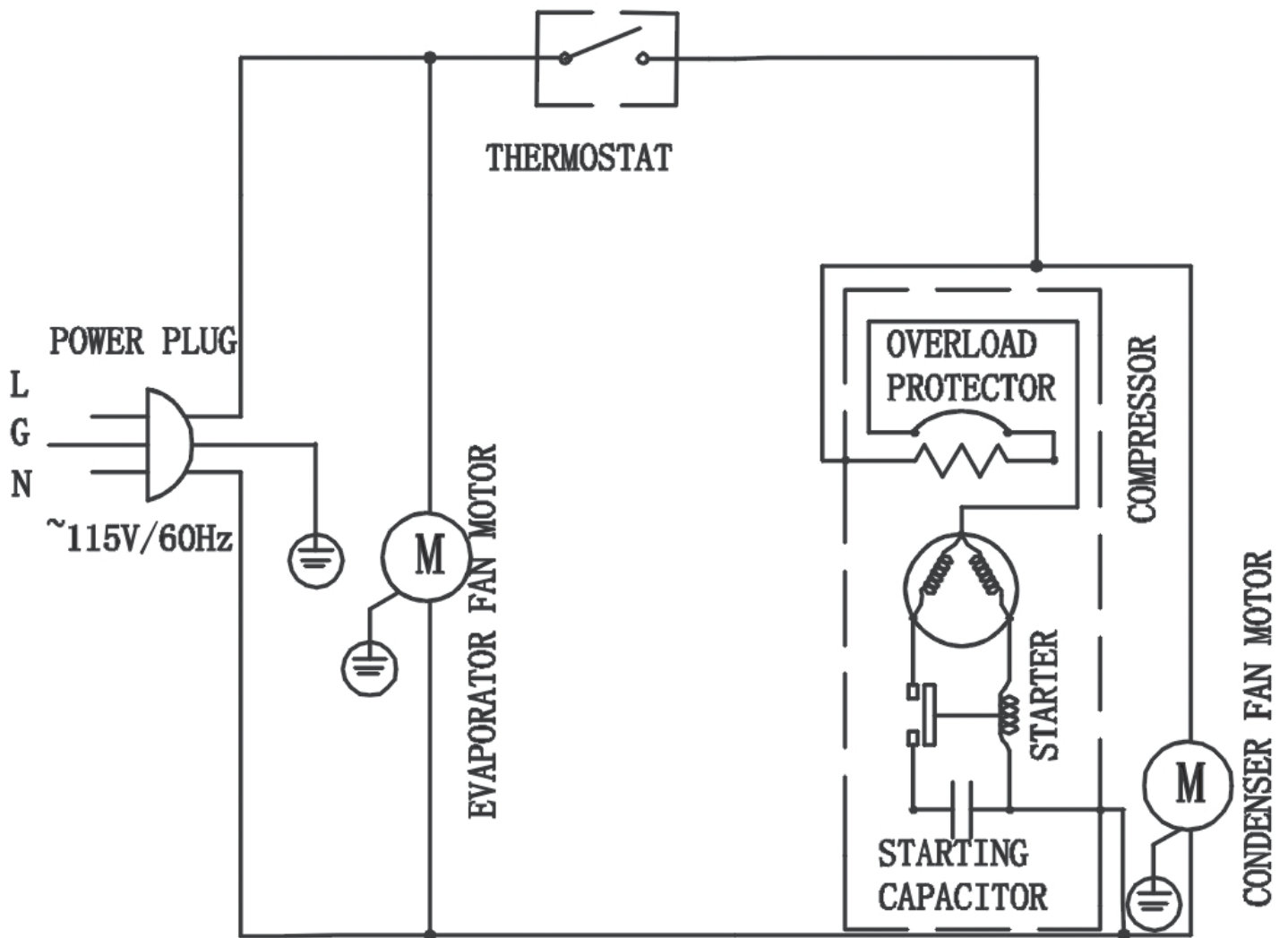

# Electrical Schematics

Model BB-CN-0017-HC 50040

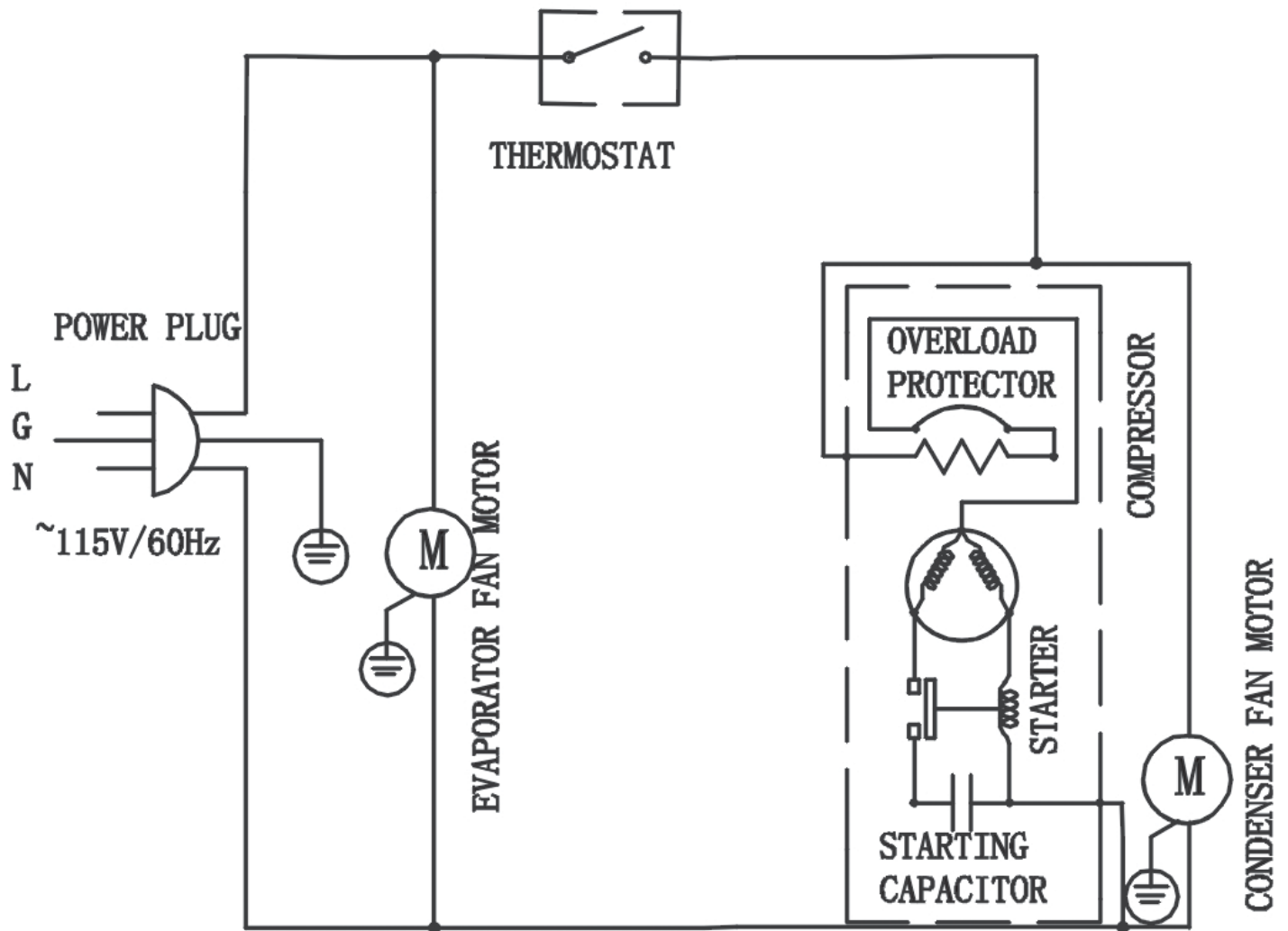

# Electrical Schematics

Model **BB-CN-0026-HC** 50041

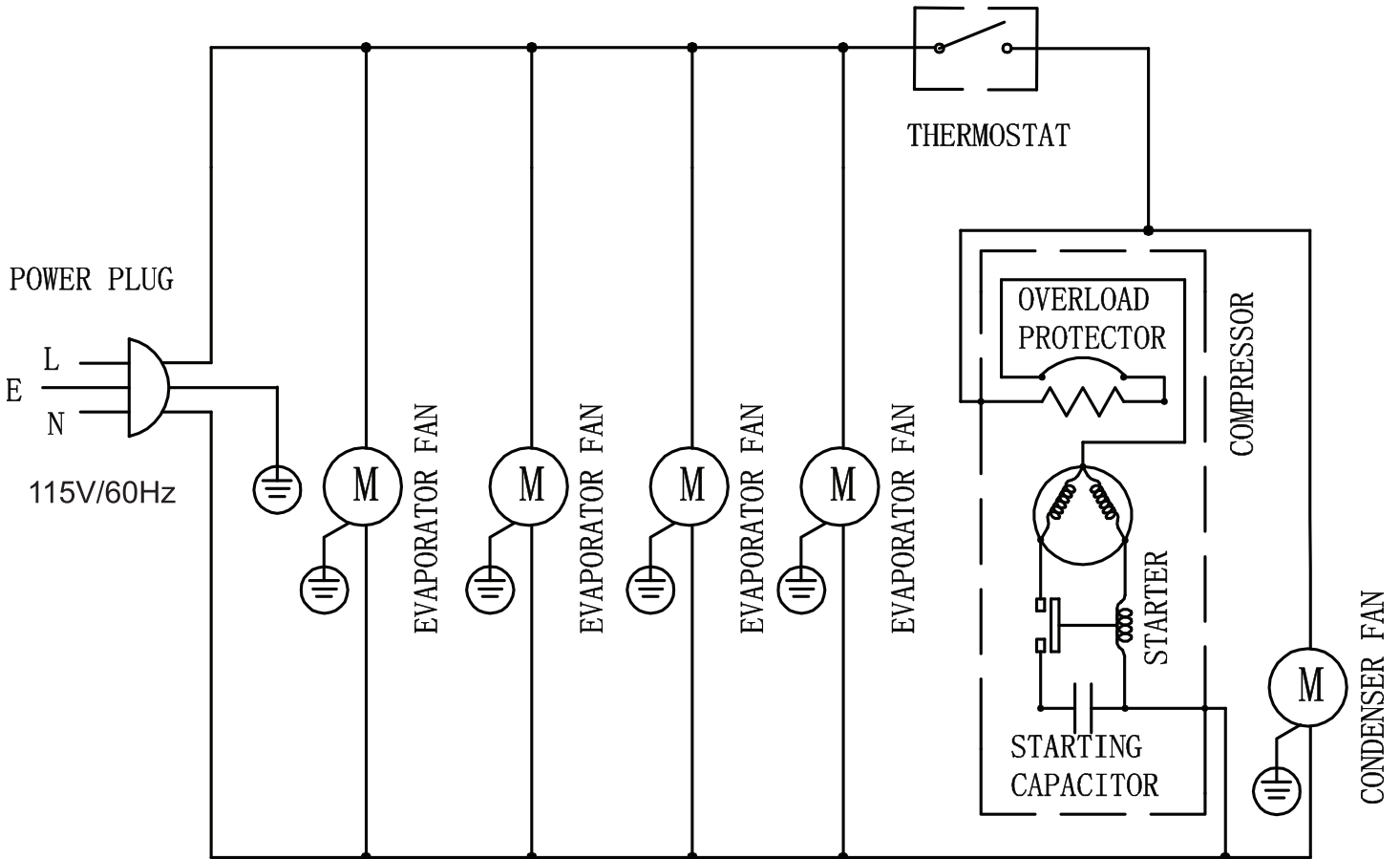



# Warranty Registration

Thank you for purchasing an Omcan product. To register your warranty for this product, complete the information below, tear off the card at the perforation and then send to the address specified below. You can also register online by visiting:

Merci d'avoir acheté un produit Omcan. Pour enregistrer votre garantie pour ce produit, complétez les informations ci-dessous, détachez la carte au niveau de la perforation, puis l'envoyer à l'adresse spécifiée ci-dessous. Vous pouvez également vous inscrire en ligne en visitant:

Gracias por comprar un producto Omcan usted. Para registrar su garantía para este producto, complete la información a continuación, cortar la tarjeta en la perforación y luego enviarlo a la dirección indicada a continuación. También puede registrarse en línea en:

[www.omcan.com/warrantyregistration.html](http://www.omcan.com/warrantyregistration.html)

For mailing in Canada

Pour postale au Canada

Por correo en Canadá

**OMCAN**

PRODUCT WARRANTY REGISTRATION

3115 Pepper Mill Court,

Mississauga, Ontario

Canada, L5L 4X5

For mailing in the US

Pour diffusion aux États-Unis

Por correo en los EE.UU.

**OMCAN**

PRODUCT WARRANTY REGISTRATION

4450 Witmer Industrial Estates, Unit 4,

Niagara Falls, New York

USA, 14305

*or email to: [service@omcan.com](mailto:service@omcan.com)*



Purchaser's Information

Name: \_\_\_\_\_

Address: \_\_\_\_\_

City: \_\_\_\_\_ Province or State: \_\_\_\_\_ Postal or Zip: \_\_\_\_\_

Country: \_\_\_\_\_

Dealer from which Purchased: \_\_\_\_\_

Dealer City: \_\_\_\_\_ Dealer Province or State: \_\_\_\_\_

Invoice: \_\_\_\_\_

Model Name: \_\_\_\_\_ Model Number: \_\_\_\_\_

Machine Description: \_\_\_\_\_

Date of Purchase (MM/DD/YYYY): \_\_\_\_\_

Would you like to extend the warranty?  Yes  No

Company Name: \_\_\_\_\_

Telephone: \_\_\_\_\_

Email Address: \_\_\_\_\_

Type of Company:

Restaurant  Bakery  Deli

Butcher  Supermarket  Caterer

Institution (specify): \_\_\_\_\_

Other (specify): \_\_\_\_\_

Serial Number: \_\_\_\_\_

Date of Installation (MM/DD/YYYY): \_\_\_\_\_

**Thank you for choosing Omcan | Merci d'avoir choisi Omcan | Gracias por elegir Omcan**



Since 1951 Omcan has grown to become a leading distributor of equipment and supplies to the North American food service industry. Our success over these many years can be attributed to our commitment to strengthen and develop new and existing relationships with our valued customers and manufacturers. Today with partners in North America, Europe, Asia and South America, we continually work to improve and grow the company. We strive to offer customers exceptional value through our qualified local sales and service representatives who provide convenient access to over 3, 500 globally sourced products.

---

Depuis 1951 Omcan a grandi pour devenir un des “leaders” de la distribution des équipements et matériel pour l’industrie des services alimentaires en Amérique du Nord. Notre succès au cours de ces nombreuses années peut être attribué à notre engagement à renforcer et à développer de nouvelles et existantes relations avec nos clients et les fabricants de valeur. Aujourd’hui avec des partenaires en Amérique du Nord, Europe, Asie et Amérique du Sud, nous travaillons continuellement à améliorer et développer l’entreprise. Nous nous efforçons d’offrir à nos clients une valeur exceptionnelle grâce à nos ventes locales qualifiées et des représentants de service qui offrent un accès facile à plus de 3500 produits provenant du monde entier.

---

Desde 1951 Omcan ha crecido hasta convertirse en un líder en la distribución de equipos y suministros de alimentos en América del Norte industria de servicios. Nuestro éxito en estos años se puede atribuir a nuestro compromiso de fortalecer y desarrollar nuevas relaciones existentes con nuestros valiosos clientes y fabricantes. Hoy con socios de América del Norte, Europa, Asia y América del Sur, que trabajan continuamente para mejorar y crecer la empresa. Nos esforzamos por ofrecer a nuestros clientes valor excepcional a través de nuestro local de ventas y representantes de los servicios que proporcionan un fácil acceso a más de 3, 500 productos con origen a nivel mundial.

