



# Countertop Gas Fryers

Items 43086, 43087, 43088, 43089

## Instruction Manual



**STOP**  
**DO NOT RETURN**  
**THIS PRODUCT TO THE STORE**

For questions or assistance with this product call OMCAN Toll Free:  
1 800 465 0234  
Customer Service  
or  
visit the Support section of  
[www.omcan.com](http://www.omcan.com)

*Revised - 11/03/2016*



Toll Free: 1-800-465-0234  
Fax: 905-607-0234  
Email: [service@omcan.com](mailto:service@omcan.com)  
[www.omcan.com](http://www.omcan.com)



# ***Table of Contents***

Item 43086 / Item 43087 / Item 43088 / Item 43089

---

<b>Section</b>	<b>Page</b>
General Information -----	3 - 4
Safety and Warranty -----	4 - 5
Technical Specifications -----	6
Installation -----	6 - 7
Assembly -----	7 - 8
Operation -----	9 - 10
Maintenance -----	11 - 12
Troubleshooting -----	12
Parts Breakdown -----	13 - 14
Warranty Registration -----	15



# General Information

---

Omcan Manufacturing and Distributing Company Inc., Food Machinery of America, Inc. dba Omcan and Omcan Inc. are not responsible for any harm or injury caused due to any person's improper or negligent use of this equipment. The product shall only be operated by someone over the age of 18, of sound mind, and not under the influence of any drugs or alcohol, who has been trained in the correct operation of this machine, and is wearing authorized, proper safety clothing. Any modification to the machine voids any warranty, and may cause harm to individuals using the machine or in the vicinity of the machine while in operation.

## CHECK PACKAGE UPON ARRIVAL

Upon receipt of an Omcan shipment please inspect for external damage. If no damage is evident on the external packaging, open carton to ensure all ordered items are within the box, and there is no concealed damage to the machine. If the package has suffered rough handling, bumps or damage (visible or concealed), please note it on the bill of lading before accepting the delivery and contact Omcan within 24 hours, so we may initiate a claim with the carrier. A detailed report on the extent of the damage caused to the machine must be filled out within three days, from the delivery date shown in the shipping documents. Omcan has no recourse for damaged products that were shipped collect or third party.

**Before operating any equipment, always read and familiarize yourself with all operation and safety instructions.**

Omcan would like to thank you for purchasing this machine. It's of the utmost importance to save these instructions for future reference. Also save the original box and packaging for shipping the equipment if servicing or returning of the machine is required.

---

Omcan Fabrication et distribution Compañie Limité et Food Machinery d'Amérique, dba Omcan et Omcan Inc. ne sont pas responsables de tout dommage ou blessure causé du fait que toute personne ait utilisé cet équipement de façon irrégulière. Le produit ne doit être exploité que par quelqu'un de plus de 18 ans, saine d'esprit, et pas sous l'influence d'une drogue ou d'alcool, qui a été formé pour utiliser cette machine correctement, et est vêtu de vêtements de sécurité approprié. Toute modification de la machine annule toute garantie, et peut causer un préjudice à des personnes utilisant la machine ou des personnes à proximité de la machine pendant son fonctionnement.

## VÉRIFIEZ LE COLIS DÈS RÉCEPTION

Dès réception d'une expédition d'Omcan veuillez inspecter pour dommages externes. Si aucun dommage n'est visible sur l'emballage externe, ouvrez le carton afin de s'assurer que tous les éléments commandés sont dans la boîte, et il n'y a aucun dommage dissimulé à la machine. Si le colis n'a subi aucune mauvaises manipulations, de bosses ou de dommages (visible ou cachée), notez-le sur le bond de livraison avant d'accepter la livraison et contactez Omcan dans les 24 heures qui suivent, pour que nous puissions engager une réclamation auprès du transporteur. Un rapport détaillé sur l'étendue des dommages causés à la machine doit être rempli dans un délai de trois jours, à compter de la date de livraison indiquée dans les documents d'expédition. Omcan n'a aucun droit de recours pour les produits endommagés qui ont été expédiés ou cueilli par un tiers transporteur.

# General Information

---

Avant d'utiliser n'importe quel équipement, toujours lire et vous familiariser avec toutes les opérations et les consignes de sécurité.

Omcan voudrais vous remercier d'avoir choisi cette machine. Il est primordial de conserver ces instructions pour une référence ultérieure. Également conservez la boîte originale et l'emballage pour l'expédition de l'équipement si l'entretien ou le retour de la machine est nécessaire.

Omcan Empresa De Fabricacion Y Distribucion Inc. Y Maquinaria De Alimentos De America, Inc. dba Omcan y Omcan Inc. no son responsables de ningun daño o perjuicio causado por cualquier persona inadecuada o el uso descuidado de este equipo. El producto solo podra ser operado por una persona mayor de 18 años, en su sano juicio y no bajo alguna influencia de droga o alcohol, y que este ha sido entrenado en el correcto funcionamiento de esta máquina, y ésta usando ropa apropiada y autorizada. Cualquier modificación a la máquina anula la garantía y puede causar daños a las personas usando la máquina mientras esta en el funcionamiento.

## REVISE EL PAQUETE A SU LLEGADA

Tras la recepcion de un envio Omcan favor inspeccionar daños externos. Si no hay daños evidentes en el empaque exterior, Habra el carton para asegurarse que todos los articulos solicitados estén dentro de la caja y no encuentre daños ocultos en la máquina. Si el paquete ha sufrido un manejo de poco cuidado, golpes o daños (visible o oculto) por favor anote en la factura antes de aceptar la entrega y contacte Omcan dentro de las 24 horas, de modo que podamos iniciar una reclamación con la compañía. Un informe detallado sobre los daños causados a la máquina debe ser llenado en el plazo de tres días, desde la fecha de entrega que se muestra en los documentos de envío. Omcan no tiene ningun recurso por productos dañados que se enviaron a recoger por terceros.

Antes de utilizar cualquier equipo, siempre lea y familiarizarse con todas las instrucciones de funcionamiento y seguridad.

Omcan le gustaría darle las gracias por la compra de esta máquina. Es de la mayor importancia para salvar estas instrucciones para futuras consultas. Además, guarda la caja original y el embalaje para el envío del equipo si servicio técnico o devolución de la máquina que se requiere.

# Safety and Warranty

---

This manual contains important information regarding your gas fryer unit. Please read this manual thoroughly prior to equipment set-up, operation and maintenance. Failure to comply with regular maintenance guidelines outlined in this manual may void the warranty. MUST READ!!!

## WARNINGS

- Do not touch any hot surfaces.



# Safety and Warranty

---

- Do not immerse unit, cord or plug in liquid at any time.
- Do not operate unattended.
- Do not use this unit for anything other than intended use.
- Do not use outdoors.
- Always use on a firm, dry and level surface at least 12" from walls or any other obstruction.
- Keep children and animals away from unit.
- Any incorrect installation, alterations, adjustments and/or improper maintenance can lead to property loss and injury. All repairs should be done by authorized professionals only.
- If gas odor is detected, shut unit down at main shutoff valve and contact service company.
- Do not store or use gasoline or other flammable vapors or liquids in the vicinity of this or any appliance.

## 1 YEAR PARTS AND LABOUR BENCH WARRANTY

Within the warranty period, contact Omcan Inc. at 1-800-465-0234 to schedule a drop off to either an Omcan authorized service depot in the area, or to an Omcan Service warehouse to repair the equipment.

Unauthorized maintenance will void the warranty. Warranty covers electrical and part failures, not improper use.

Please see [www.omcan.com/warranty.html](http://www.omcan.com/warranty.html) for complete info.

### WARNING:

The packaging components (cardboard, polyethylene, and others) are classified as normal solid urban waste and can therefore be disposed of without difficulty.

In any case, for suitable recycling, we suggest disposing of the products separately (differentiated waste) according to the current norms.

**DO NOT DISCARD ANY PACKAGING MATERIALS IN THE ENVIRONMENT!**

# Technical Specifications

---

Item Number	43086	43087	43088	43089
Gas Type	Natural Gas	Propane Gas	Natural Gas	Propane Gas
BTU	26,500		53,000	
Oil Capacity	15 lbs. / 7 kg.		30 lbs. / 14 kg.	
Temperature	200 - 400°F / 93 - 204°C			
Weight	28 kg. / 62 lbs.		38.3 kg. / 84 lbs.	
Dimensions	33" x 11" x 30" / 840 x 280 x 760 mm		33" x 17" x 30" / 840 x 430 x 760 mm	

## CONSTRUCTION

- Welded 16 gauge stainless steel tank with a super smooth machine finish ensures easy cleaning.
- Long lasting baffles are mounted in the heat exchange tubes to provide maximum heating and combustion efficiency.
- Standing pilot light design provides a ready flame when heat is required.
- Cabinet is constructed of stainless steel front and door with galvanized sides and back.

## CONTROLS

- Thermostat maintains temperature between 200°F (93°C) and 400°F (204°C).
- Integrated gas control valve acts as a manual and pilot valve, automatic pilot valve, gas filter, pressure regulator and automatic main valve.
- Gas control valve prevents gas flow to the main burner until pilot is established and shuts off all the gas flow automatically if the pilot flame goes out.
- Temperature limit automatically shuts off all gas flow if the fryer temperature exceeds 450°F (232°C).

## OPERATIONS

- Standing pilot and thermostat maintain temperature automatically at the selected temperature (between 200°F (93°C) and 400°F (204°C)).
- Front 1-1/4" drain, for quick draining.

# Installation

---

Before installing the fryer, verify what type of gas (natural or propane) agrees with the specifications on the fryer date plate, which is located on the inside of the door panel. Make sure the fryer is configured for the proper elevation.

### Minimum clearance from combustible construction:

- 6" (15 cm) from the side of the fryer.
- 6" (15 cm) from the back of the fryer.
- The fryer may not be installed on combustible floors.

# Installation

---

## Minimum clearance from noncombustible construction:

- 6" from side of fryer.
- 6" from back of fryer.

## Between the fryer and any open-top flame units:

- 16" (41 cm).
- Install fryer in an area with sufficient air supply for gas combustion at fryer burners.
- Do not obstruct the flow of combustion and ventilation air.
- Provide adequate clearance for air openings into the combustion chamber.
- Do not permit fans to blow directly onto fryer.
- Avoid wall-type fans, which create cross-currents within a room.
- Avoid open windows next to sides or back.

## CODES AND STANDARDS

The installer of this unit should be aware of state, county or local code for connecting this equipment to determine if an external regulator is required.

# Assembly

---

The fryer must be restrained to prevent tipping and the splashing of hot liquid. The means of restraint may be the manner of installation, such as connection to a battery of appliances, installing the fryer in an alcove, or by separate means such as adequate ties.

**Note:** The gas supply pressure at gas inlet should be less than 3.5 kPa.

1. Turn all burner controls OFF.
  - Turn gas supply valve OFF.
2. Reconfigure Pressure Regulator
  - Remove converter cap and pin from pressure regulator.
  - Carefully remove pin from cap.
  - Invert pin and reinstall in cap.
  - Be sure gasket is in place on cap, then securely reinstall cap and pin on pressure regulator.
3. Remove burners.
4. Remove and discard orifice hoods from burner control nozzles; install orifice hoods from kit.
5. Reinstall burners.
6. Turn gas supply valve ON.
7. Adjust pilot flames.
8. Adjust burner flames.
9. Affix propane conversion label to rear of appliance, near the nameplate.

The procedure is complete.

# Assembly

---

## TO CONNECT THE VENT

- Comply with Vapor Removal from Cooking Equipment, ANSI-NFPA Standard #96 (latest edition), available from the National Fire Protection Association, Batterymarch Park, Quincy, MA 02269.
- Locate the fryer under a hood with adequate connection to an exhaust duct. The hood must extend 6" (15 cm) beyond fryer on both sides.
- Clearance above the fryer should be adequate for combustion by-products to be removed efficiently.
- An 18" (46 cm) minimum clearance should be maintained between the flue vent and the filters of the hood venting system.
- Never make vent connections directly to the fryer.
- Do not obstruct the flow of the gases from the appliance. Proper air balance should be maintained in the room.

## TO CONNECT GAS

- All gas supply connections and any pipe joint compound must be resistant to the action of propane gases.
- The gas inlet is located on the lower rear of the fryer. Codes require that a gas shutoff valve be installed in the gas line ahead of the fryer.
- The gas supply line must be at least the equivalent of ½" X (12.7 mm) iron pipe for single units and 1-1/4" (31.75 mm) for batteries. If using the optional quick-disconnect flex hose, ¾" X (19mm) iron pipe for single units and 1-1/4" (31.75 mm) iron pipe for batteries.
- Make sure the pipes are clean and free of obstructions, dirt, and piping compound.
- A battery requires one or two connections of appropriate size for the gas requirement.

**Note:** Prior to lighting, check all joints in the gas supply line for leaks. Use soap and water solution. Do not use an open flame.

After piping has been checked for leaks, fully purge gas pipes to remove air.

## GAS PRESSURES (ALL MODELS)

The gas pressure should be set at 5" W.C. (Water Column) (1.25 kPa) of pressure for natural gas and 10" W.C. (2.54kPa) of pressure for propane gas. If incoming pressure exceeds ½ PSI (3.5 kPa), an additional pressure regulator must be installed.

## TESTING THE GAS SUPPLY PIPING SYSTEM

When test pressures exceed ½ PSI (3.5 kPa), the fryer and its individual shutoff valve must be disconnected from the gas supply piping system. When test pressures are ½ PSI (3.5 kPa) or less, the fryer must be isolated from the gas supply piping system by closing its individual shutoff valve.

## TO LEVEL

- Check the level of the fryer by placing a level on top of the fryer after gas connections have been made.
- Ensure that the fryer is level front-to-back and side-to-side in the final installed position.



Before any food preparation, thoroughly wipe protective oil from all surface parts and the tank interior with hot soapy water to remove any film residue and dust or debris.

### **To Fill Tank with Oil:**

- Solid oil should NOT be used with fryers.
  - Melting solid oil will damage the tank and void your warranty.
1. Close the drain valve.
  2. Fill the fryer tank with liquid oil.
  3. Oil level should be between the min. and max. lines in the fryer tank.
  4. Oil will expand when heated. Do not fill the fryer tank past the MAX line.
  5. Add fresh oil as needed to maintain oil level.

### **Lighting the Pilot:**

1. Open the door.
2. Turn the thermostat OFF. The thermostat is located behind the door.
3. Push the gas control valve knob and turn to OFF. Wait 5 minutes for unburned gas to vent.
4. Push and turn gas control valve knob to the "L" in PILOT.
5. While still holding the knob in, light the pilot with a lit flame. Continue to depress the knob until pilot remains lit when knob is released. If the pilot does not remain lit, repeat step 3 through 5.
6. Depress and turn gas control knob to ON.
7. If gas supply is interrupted, repeat steps 2 through 6.

### **Turning Fryer On:**

1. Set the temperature knob to desired temperature.
2. After the set temperature has been reached, the thermostat shuts off the gas flow to burners.
3. The pilot remains lit. The burners will cycle on and off, maintaining the set temperature.

If the oil becomes overheated, a high-temperature shutoff device will turn the gas valve off and extinguish the pilot. If the fryer shuts down due to overheating, DO NOT relights the pilot until the oil temperature is below 300°F (149°C). If an overheating situation persists, contact your local authorized service office.

### **Turning Fryer Off:**

1. Turn the thermostat OFF.
2. To keep the pilot lit, turn the gas valve to "L" in Pilot.
3. To shut off all gas to the system, including the pilot, turn the gas valve knob to OFF.

### **Extended Shutdown**

1. Turn the thermostat knob to OFF.
2. Push in the pilot knob and turn to OFF.
3. Thoroughly drain the fryer. Refer to DRAINING THE FRYER.
4. Clean the fryer according to CLEANING.
5. Turn off the main gas shutoff valve.

### **BASIC USAGE**

1. Set the desired temperature and allow oil to heat.

# Operation

---

2. To ensure equally fried items, make sure food pieces are about the same size.
3. Drain or wipe dry raw or wet foods to minimize splatter when lowering into hot oil.
4. Add fresh oil as needed.

## Guidelines for Fry Baskets

- Do not overfill baskets.
- Carefully lower basket into oil.
- When frying doughnuts and fritters, turn product only once during frying.
- When cooking French fries or onion rings, shake the basket several times carefully, as not to splatter oil.
- Batter-covered foods should be dropped carefully, one by one, into oil or basket.
- If using the basket, first dip the basket into the oil to reduce batter-build up on basket surfaces.
- When frying is completed, remove basket or product.
- Hang basket on rear hanger.

## Extending Oil Life

Oil life can be extended by the following guidelines:

- Do not salt foods over the fryer.
- Use good-quality oil.
- Filter oil daily (at a minimum).
- Replace oil if it becomes poorly flavored.
- Keep equipment and surrounding area clean.
- Set thermostat correctly.
- Remove excess moisture and particles from food products before placing on fryer.

## Draining the Tank

- Turn the thermostat to OFF.
- To keep the pilot lit, turn the gas valve to PILOT.
- Direct the drain spout into the container that you want to drain the oil into.
- Open the drain valve. The oil will drain into the container. When the container is full or the fryer tank is empty, close the drain valve. Repeat this step until the fryer is empty.
- If desired, perform the weekly clean-out as described under CLEANING.
- Once tank is completely empty, add new oil and set thermostat to desired temperature.

## Daily Filtering

- Filter oil at least once a day. Refer to the instructions provided with your filtering equipment.
- A cold fryer will not drain properly.
- Always filter oil between 250°F and 350°F.
- The oil in the cold zone area will remain hard if the heat is only on for a few minutes.
- If necessary, use the clean-out rod to carefully stir the hard oil to an area above the cold zone where it will melt.
- Use the tank brush to help clear sides and tubes of debris.

# Maintenance

---

- Hot oil and hot parts can cause burns.
- Use care when operating, cleaning, and servicing the fryer.
- Spilling hot fryer compound can cause severe burns.
- Do not move fryer without draining all frying compound from the tank.
- The fryer should be restrained to prevent tipping when installed in order to avoid the splashing of hot liquid.
- The means of restraint may be the manner of installation, such as connection to a battery of appliances or installing the fryer in an alcove, or by separate means, such as adequate ties.

## CLEANING

**NOTE:** To maintain cleanliness and increase service life, the fryer should be cleaned daily. Do not immerse in water or any other liquid, if liquid enters the electrical compartment it may cause a short circuit or electrical shock.

1. Hot oil and hot parts can cause burns. Use care when operating, cleaning, and servicing the fryer.
2. Clean the unit with the tank brush and a damp cloth then polish with a soft dry cloth.
3. Clean all exterior surfaces with warm soapy water.
4. To avoid fingerprints on highly polished surfaces of stainless steel, apply a cleaner that will leave a thin oily or waxy film.
5. To avoid damage, do not use abrasive cleaners or metallic scouring pads.
6. Use a self-soaping, non-metallic scouring pad for stubborn discolorations.
7. If soap or chemical cleaners are used, be sure they are completely rinsed away with clear water immediately after cleaning. Chemical residue could damage or corrode the surfaces of the unit.

## BOIL OUT

Procedure should be done weekly or as required.

- Drain the tank as described under DRAINING THE TANK.
- Once the shortening has been drained, flush out scraps and sediment with a small amount of warm shortening, using tank brush. Allow the tank to drain thoroughly.
- Close the drain valve and fill tank with non-corrosive, grease-dissolving commercial cleaner. Follow the manufacturer's instructions. Do not use chlorine or sulfate/sulfide cleaners.
- Add commercial boil-out solution. Solution level must be between the MIN and MAX levels on the fryer tank.
- Set thermostat to the temperature recommended for the solution being used. Allow solution to simmer for about 15 to 20 minutes.
- Drain the cleaning solution from the tank.
- Close the drain valve and refill the tank with water. Add 1 cup (1/4 L) of vinegar to neutralize alkaline left by the cleaner. Solution level must be between the MIN and MAX level on the fryer tank.
- Bring the solution to a simmer only, then turn the thermostat off. Allow to stand for a few minutes.
- Drain the tank according to DRAINING THE TANK. Rinse thoroughly with clear, hot water. All traces of cleaner must be removed. Dry the tank thoroughly.
- Close the drain valve and add shortening. Follow the FILLING TANK WITH SHORTENING procedure in this manual. The fryer is now ready for use.

# Maintenance

---

## FLUE VENT INSPECTION

- When the fryer is cool, inspect annually. Check the flue and clear any obstructions.

### Service in the US and Canada

Contact your local Service office or address on the front of this manual.

# Troubleshooting

---

Problem	Cause
No heat	Thermostat dial is not turned on. Pilot is not lit. Gas supply is not turned on. Wire connections are loose (call for service). Wire connections need cleaning (call service). Thermopile (call service).
Insufficient or too much heat	Thermostat dial is not set to desired temperature. High limit is tripped (call for service). Temperature probe (call for service).
Tank will not drain	Shortening is too cold. Drain pipe is clogged with debris.

## REFERENCE

Item Number	Model Number	Description	Manufacturer Model Number
43086	-	Countertop Fryer with Thermostat Control 15 Lbs Natural Gas ETL	UR-CF15T-NG
43087	-	Countertop Fryer with Thermostat Control 15 Lbs Propane ETL	UR-CF15T-LPG
43088	-	Countertop Fryer with Thermostat Control 30 Lbs Natural Gas ETL	UR-CF30T-NG
43089	-	Countertop Fryer with Thermostat Control 30 Lbs Propane ETL	UR-CF30T-LPG

# Parts Breakdown

- Item 43086
- Item 43087
- Item 43088
- Item 43089

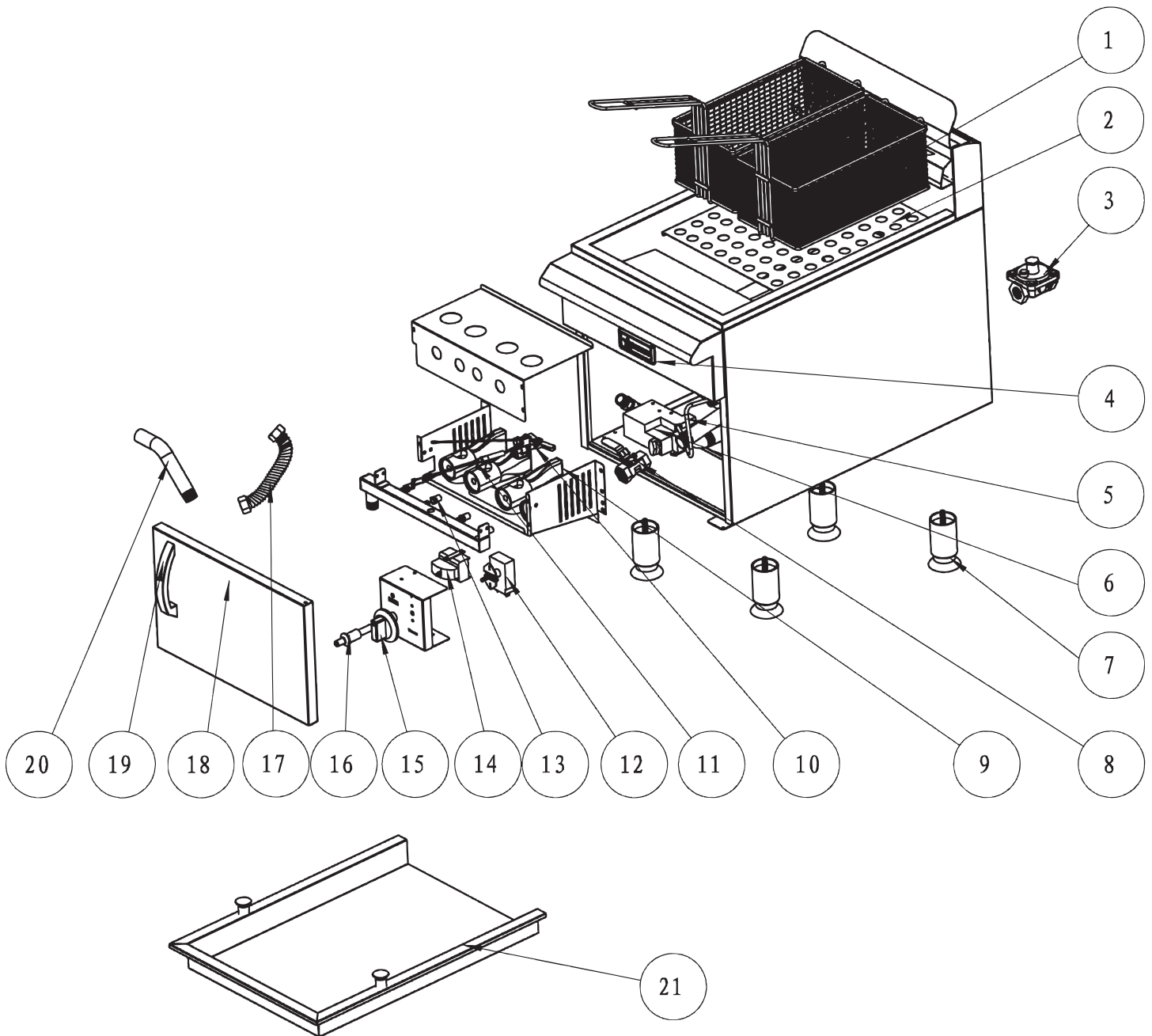

# Parts Breakdown

## Item 43086

## Item 43087

Item No.	Description	Position	Item No.	Description	Position	Item No.	Description	Position
77941	Fryer Basket for UR-CF15T-NG	1	77951	Valve, Oil Drain for UR-CF15T-NG	8	77960	Knob for UR-CF15T-NG	15
77942	Filter Panel for UR-CF15T-NG	2	77952	Burner for UR-CF15T-NG	9	77961	Piezo Igniter for UR-CF15T-NG	16
77944	Regulator for UR-CF15T-NG	3	77954	Flame Device System for UR-CF15T-NG	10	77962	Bellows for UR-CF15T-NG	17
79005	Regulator for UR-CF15-LP	3	77955	Thermopile for UR-CF15T-NG	11	77963	Door for UR-CF15T-NG	18
77945	Brand for UR-CF15T-NG	4	77956	Gas Thermostat for UR-CF15T-NG	12	77965	Door Handle for UR-CF15T-NG	19
77946	Pilot Pipe Assy. for UR-CF15T-NG	5	77958	Orifice for UR-CF15T-NG	13	77966	Oil Drain Tube for UR-CF15T-NG	20
77949	Gas Safety Control Valve for UR-CF15T-NG	6	79006	Orifice for UR-CF15-LP	13	77967	Cover (Optional Accessories) for UR-CF15T-NG	21
72410	Foot for UR-CF15T-NG	7	77959	LC Series Limit Control for UR-CF15T-NG	14			

## Item 43088

## Item 43089

Item No.	Description	Position	Item No.	Description	Position	Item No.	Description	Position
77941	Fryer Basket for UR-CF30T-NG	1	77951	Valve, Oil Drain for UR-CF30T-NG	8	77960	Knob for UR-CF30T-NG	15
77943	Filter Panel for UR-CF30T-NG	2	77952	Burner for UR-CF30T-NG	9	77961	Piezo Igniter for UR-CF30T-NG	16
77944	Regulator for UR-CF30T-NG	3	77954	Flame Device System for UR-CF30T-NG	10	77962	Bellows for UR-CF30T-NG	17
79007	Regulator for UR-CF30-LP	3	77955	Thermopile for UR-CF30T-NG	11	77964	Door for UR-CF30T-NG	18
77945	Brand for UR-CF30T-NG	4	77956	Gas Thermostat for UR-CF30T-NG	12	77965	Door Handle for UR-CF30T-NG	19
77947	Pilot Pipe Assy. for UR-CF30T-NG	5	77958	Orifice for UR-CF30T-NG	13	77966	Oil Drain Tube for UR-CF30T-NG	20
77949	Gas Safety Control Valve for UR-CF30T-NG	6	79008	Orifice for UR-CF30-LP	13	77968	Cover (Optional Accessories) for UR-CF30T-NG	21
72410	Foot for UR-CF30T-NG	7	77959	LC Series Limit Control for UR-CF30T-NG	14			



# Warranty Registration

Thank you for purchasing an Omcan product. To register your warranty for this product, complete the information below, tear off the card at the perforation and then send to the address specified below. You can also register online by visiting:

Merci d'avoir acheté un produit Omcan. Pour enregistrer votre garantie pour ce produit, complétez les informations ci-dessous, détachez la carte au niveau de la perforation, puis l'envoyer à l'adresse spécifiée ci-dessous. Vous pouvez également vous inscrire en ligne en visitant:

Gracias por comprar un producto Omcan usted. Para registrar su garantía para este producto, complete la información a continuación, cortar la tarjeta en la perforación y luego enviarlo a la dirección indicada a continuación. También puede registrarse en línea en:

**[www.omcan.com/warrantyregistration.html](http://www.omcan.com/warrantyregistration.html)**

**For mailing in Canada**

**Pour postale au Canada**

**Por correo en Canadá**

**For mailing in the US**

**Pour diffusion aux États-Unis**

**Por correo en los EE.UU.**

**OMCAN**

PRODUCT WARRANTY REGISTRATION

3115 Pepper Mill Court,

Mississauga, Ontario

Canada, L5L 4X5

**OMCAN**

PRODUCT WARRANTY REGISTRATION

4450 Witmer Industrial Estates, Unit 4,

Niagara Falls, New York

USA, 14305

**or email to: [service@omcan.com](mailto:service@omcan.com)**



Purchaser's Information

Name: \_\_\_\_\_

Address: \_\_\_\_\_

City: \_\_\_\_\_ Province or State: \_\_\_\_\_ Postal or Zip: \_\_\_\_\_

Country: \_\_\_\_\_

Dealer from which Purchased: \_\_\_\_\_

Dealer City: \_\_\_\_\_ Dealer Province or State: \_\_\_\_\_

Invoice: \_\_\_\_\_

Model Name: \_\_\_\_\_ Model Number: \_\_\_\_\_

Machine Description: \_\_\_\_\_

Date of Purchase (MM/DD/YYYY): \_\_\_\_\_

Would you like to extend the warranty?  Yes  No

Company Name: \_\_\_\_\_

Telephone: \_\_\_\_\_

Email Address: \_\_\_\_\_

Type of Company:

Restaurant  Bakery  Deli

Butcher  Supermarket  Caterer

Institution (specify): \_\_\_\_\_

Other (specify): \_\_\_\_\_

Serial Number: \_\_\_\_\_

Date of Installation (MM/DD/YYYY): \_\_\_\_\_

**Thank you for choosing Omcan | Merci d'avoir choisi Omcan | Gracias por elegir Omcan**



Since 1951 Omcan has grown to become a leading distributor of equipment and supplies to the North American food service industry. Our success over these many years can be attributed to our commitment to strengthen and develop new and existing relationships with our valued customers and manufacturers. Today with partners in North America, Europe, Asia and South America, we continually work to improve and grow the company. We strive to offer customers exceptional value through our qualified local sales and service representatives who provide convenient access to over 3,500 globally sourced products.

---

Depuis 1951 Omcan a grandi pour devenir un des “leaders” de la distribution des équipements et matériel pour l’industrie des services alimentaires en Amérique du Nord. Notre succès au cours de ces nombreuses années peut être attribué à notre engagement à renforcer et à développer de nouvelles et existantes relations avec nos clients et les fabricants de valeur. Aujourd’hui avec des partenaires en Amérique du Nord, Europe, Asie et Amérique du Sud, nous travaillons continuellement à améliorer et développer l’entreprise. Nous nous efforçons d’offrir à nos clients une valeur exceptionnelle grâce à nos ventes locales qualifiées et des représentants de service qui offrent un accès facile à plus de 3500 produits provenant du monde entier.

---

Desde 1951 Omcan ha crecido hasta convertirse en un líder en la distribución de equipos y suministros de alimentos en América del Norte industria de servicios. Nuestro éxito en estos años se puede atribuir a nuestro compromiso de fortalecer y desarrollar nuevas relaciones existentes con nuestros valiosos clientes y fabricantes. Hoy con socios de América del Norte, Europa, Asia y América del Sur, que trabajan continuamente para mejorar y crecer la empresa. Nos esforzamos por ofrecer a nuestros clientes valor excepcional a través de nuestro local de ventas y representantes de los servicios que proporcionan un fácil acceso a más de 3,500 productos con origen a nivel mundial.

