



**Refrigerated Showcases**  
*Models RS-CN-0270, 0370, 0370-S*  
*Item 39539, 40519, 39540*  
**Instruction Manual**



**STOP**  
**DO NOT RETURN**  
**THIS PRODUCT TO THE STORE**

For questions or assistance with this product call OMCAN Toll Free: 1 800 465 0234  
Customer Service  
or  
visit the Support section of [www.omcan.com](http://www.omcan.com)

*Revised - 01/26/2018*



Toll Free: 1-800-465-0234  
Fax: 905-607-0234  
Email: [service@omcan.com](mailto:service@omcan.com)  
[www.omcan.com](http://www.omcan.com)

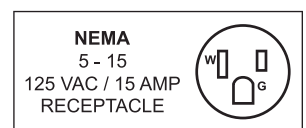

# ***Table of Contents***

Model RS-CN-0270 / Model RS-CN-0370 / Model RS-CN-0370-S

---

<b>Section</b>	<b>Page</b>
General Information -----	3 - 4
Safety and Warranty -----	4 - 6
Technical Specifications -----	6 - 7
Operation -----	7
Maintenance -----	8
Troubleshooting -----	9
Parts Breakdown -----	10 - 15
Electrical Schematics -----	16 - 17
Notes -----	18
Warranty Registration -----	19



# General Information

---

Omcan Manufacturing and Distributing Company Inc., Food Machinery of America, Inc. dba Omcan and Omcan Inc. are not responsible for any harm or injury caused due to any person's improper or negligent use of this equipment. The product shall only be operated by someone over the age of 18, of sound mind, and not under the influence of any drugs or alcohol, who has been trained in the correct operation of this machine, and is wearing authorized, proper safety clothing. Any modification to the machine voids any warranty, and may cause harm to individuals using the machine or in the vicinity of the machine while in operation.

## CHECK PACKAGE UPON ARRIVAL

Upon receipt of an Omcan shipment please inspect for external damage. If no damage is evident on the external packaging, open carton to ensure all ordered items are within the box, and there is no concealed damage to the machine. If the package has suffered rough handling, bumps or damage (visible or concealed), please note it on the bill of lading before accepting the delivery and contact Omcan within 24 hours, so we may initiate a claim with the carrier. A detailed report on the extent of the damage caused to the machine must be filled out within three days, from the delivery date shown in the shipping documents. Omcan has no recourse for damaged products that were shipped collect or third party.

**Before operating any equipment, always read and familiarize yourself with all operation and safety instructions.**

Omcan would like to thank you for purchasing this machine. It's of the utmost importance to save these instructions for future reference. Also save the original box and packaging for shipping the equipment if servicing or returning of the machine is required.

---

Omcan Fabrication et distribution Compagnie Limitée et Food Machinery d'Amérique, dba Omcan et Omcan Inc. ne sont pas responsables de tout dommage ou blessure causé du fait que toute personne ait utilisé cet équipement de façon irrégulière. Le produit ne doit être exploité que par quelqu'un de plus de 18 ans, sain d'esprit, et pas sous l'influence d'une drogue ou d'alcool, qui a été formé pour utiliser cette machine correctement, et est vêtu de vêtements de sécurité appropriés. Toute modification de la machine annule toute garantie, et peut causer un préjudice à des personnes utilisant la machine ou des personnes à proximité de la machine pendant son fonctionnement.

## VÉRIFIEZ LE COLIS DÈS RÉCEPTION

Dès réception d'une expédition d'Omcan veuillez inspecter pour dommages externes. Si aucun dommage n'est visible sur l'emballage externe, ouvrez le carton afin de s'assurer que tous les éléments commandés sont dans la boîte, et il n'y a aucun dommage dissimulé à la machine. Si le colis n'a subi aucune mauvaises manipulations, de bosses ou de dommages (visible ou cachée), notez-le sur le bond de livraison avant d'accepter la livraison et contactez Omcan dans les 24 heures qui suivent, pour que nous puissions engager une réclamation auprès du transporteur. Un rapport détaillé sur l'étendue des dommages causés à la machine doit être rempli dans un délai de trois jours, à compter de la date de livraison indiquée dans les documents d'expédition. Omcan n'a aucun droit de recours pour les produits endommagés qui ont été expédiés ou cueilli par un tiers transporteur.

# General Information

---

Avant d'utiliser n'importe quel équipement, toujours lire et vous familiariser avec toutes les opérations et les consignes de sécurité.

Omcan voudrais vous remercier d'avoir choisi cette machine. Il est primordial de conserver ces instructions pour une référence ultérieure. Également conservez la boîte originale et l'emballage pour l'expédition de l'équipement si l'entretien ou le retour de la machine est nécessaire.

Omcan Empresa De Fabricacion Y Distribucion Inc. Y Maquinaria De Alimentos De America, Inc. dba Omcan y Omcan Inc. no son responsables de ningun daño o perjuicio causado por cualquier persona inadecuada o el uso descuidado de este equipo. El producto solo podra ser operado por una persona mayor de 18 años, en su sano juicio y no bajo alguna influencia de droga o alcohol, y que este ha sido entrenado en el correcto funcionamiento de esta máquina, y ésta usando ropa apropiada y autorizada. Cualquier modificación a la máquina anula la garantía y puede causar daños a las personas usando la máquina mientras esta en el funcionamiento.

## REVISE EL PAQUETE A SU LLEGADA

Tras la recepcion de un envio Omcan favor inspeccionar daños externos. Si no hay daños evidentes en el empaque exterior, Habra el carton para asegurarse que todos los articulos solicitados estén dentro de la caja y no encuentre daños ocultos en la máquina. Si el paquete ha sufrido un manejo de poco cuidado, golpes o daños (visible o oculto) por favor anote en la factura antes de aceptar la entrega y contacte Omcan dentro de las 24 horas, de modo que podamos iniciar una reclamación con la compañía. Un informe detallado sobre los daños causados a la máquina debe ser llenado en el plazo de tres días, desde la fecha de entrega que se muestra en los documentos de envío. Omcan no tiene ningun recurso por productos dañados que se enviaron a recoger por terceros.

Antes de utilizar cualquier equipo, siempre lea y familiarizarse con todas las instrucciones de funcionamiento y seguridad.

Omcan le gustaría darle las gracias por la compra de esta máquina. Es de la mayor importancia para salvar estas instrucciones para futuras consultas. Además, guarda la caja original y el embalaje para el envío del equipo si servicio técnico o devolución de la máquina que se requiere.

# Safety and Warranty

---

## HANDLING AND INSTALLATION

<b>Handle with care</b>	<b>Storage</b>
Unplug wall socket before moving. Never tilt the refrigerator over 45 degrees during handling.	Always store the refrigerator in a dry place.



# Safety and Warranty

<p><b>Sufficient space</b> To allow for proper air circulation and increased refrigeration capabilities, the refrigerator must have at least 4 inches of space between wall and unit.</p>	<p><b>Proper ventilation</b> Always place the refrigerator in an area with good ventilation. For first time use, wait at least 2 hours before plugging into wall socket.</p>
<p><b>Away from heat source</b> Never place the refrigerator near any type of heat source or in direct sunlight, as it reduces refrigeration capabilities.</p>	<p><b>No heavy load</b> Never put heavy items on top of the refrigerator.</p>
<p><b>No altercations/tampering</b> Never tamper with or make changes to the refrigerator. Changes and add-ons should not be installed to the inside or outside of the refrigerator.</p>	<p><b>Stable location</b> Unpack and place the refrigerator on flat, solid ground.</p>

## PREPARATION AND POWER SUPPLY

<p><b>Exclusive power outlet</b> Power supply should be 110V, single phase AC with exclusive single phase three pin outlet (125V/15A) and fuse. The power outlet must be in close proximity to the ground.</p>	<p><b>No shared power outlets</b> Refrigerator cable should never share the power outlet with any other appliance, as cable will overheat and may result in a fire.</p>
<p><b>Protect cables</b> Extra caution should be used when handling cables, as broken or damaged cables can cause sparking and may result in a fire.</p>	<p><b>No water flushing</b> Never flush the refrigerator surface. This can cause leakage, which may result in electrical damage or fire.</p>
<p><b>Never store flammables and explosives</b> No explosives or flammables should be stored in, or in proximity to, the refrigerator, such as gasoline, alcohol, and adhesives.</p>	<p><b>No spray</b> Never spray flammables such as paint or coating near the refrigerator. This may cause fire or malfunction.</p>
<p><b>After power outage</b> After a power outage or the unplugging of the refrigerator, wait at least 5 minutes before plugging it back in.</p>	<p><b>No medicine</b> Medicine should not be stored inside of the refrigerator.</p>

## 1 YEAR PARTS AND LABOUR WARRANTY

Within the warranty period, contact Omcan Inc. at 1-800-465-0234 to schedule an Omcan authorized service technician to repair the equipment locally.

Unauthorized maintenance will void the warranty. Warranty covers electrical and part failures, not improper use.

Please see [www.omcan.com/warranty.html](http://www.omcan.com/warranty.html) for complete info.

# Safety and Warranty

## WARNING:

The packaging components are classified as normal solid urban waste and can therefore be disposed of without difficulty.

In any case, for suitable recycling, we suggest disposing of the products separately (differentiated waste) according to the current norms.

**DO NOT DISCARD ANY PACKAGING MATERIALS IN THE ENVIRONMENT!**

# Technical Specifications



Model	RS-CN-0270	RS-CN-0370	RS-CN-0370-S
Rated Input Power	490 W	500W	
Rated Current	5.5 A	6 A	
Refrigerant & Injection	R134a (260g)	R134a (280g)	
Refrigeration Temperature	2-8°C / 35.6-46.4°F		
Rated Frequency	60 Hz		
Type of Climate	4		
Protection Mode	I		
Lamp Power	15 W (LED)		
Rated Voltage	~110V		
Foaming Agent	C5H10		

# Technical Specifications

<b>Storage Volume</b>	270 L / 9.5 cu. ft.	370 L / 13 cu. ft.	
<b>Net Weight</b>	135 kgs. / 297.6 lbs.	155 kgs. / 341.7 lbs.	
<b>Gross Weight</b>	159 kgs. / 350.5 lbs.	193 kgs. / 425.5 lbs.	
<b>Overall Dimensions</b>	915 x 675 x 1220mm 36" x 26.6" x 48"	1215 x 675 x 1220mm 47.8" x 26.6" x 48"	1215 x 675 x 1210mm 47.8" x 26.6" x 47.6"
<b>Packaging Dimensions</b>	1020 x 765 x 1440mm 40.2" x 30.1" x 56.7"	1320 x 765 x 1440mm 52" x 30.1" x 56.7"	
<b>Item Number</b>	39539	40519	39540

## Operation

### BEFORE USE

- Plug refrigerator into the 110V exclusive socket.
- After the refrigerator is running, confirm that air suction/filtration is in order and that it is sufficiently cold. After checking to make sure the refrigerator is working properly, it may be used.

### DIGITAL TEMPERATURE CONTROLLER

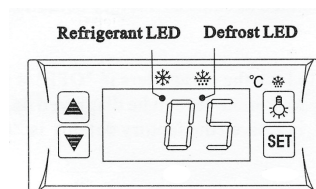

Small, integrated digital controller, which is applicable to the compressor of 1 Hp.

Main functions are: Temperature Display/Temperature Control/Manual-Automatic /Light Control/Value Storing/Self-Testing/Parameter Locking.

### FRONT PANEL OPERATION

1. Set temperature: Press **SET** button; set temperature will be displayed. Press **▲** or **▼** button to modify and store the displayed value. Press **SET** button to exit the adjustment and display the cold-room temperature.
2. If no button is pressed within 10 seconds, the cold-room temperature will be displayed.
3. Lighting: Press **☀** button to activate light in refrigerator; press again to turn off. Manual start/stop defrost: Press **☀** button and hold for 6 seconds to either defrost or to stop defrost.
4. Refrigeration LED: During refrigeration, the LED is on. When the cold room temperature is constant, the LED is off. During delay start, the LED flashes.
5. Defrost LED: During defrosting, the LED is on. When it stops defrosting, the LED is off. During the delay of defrost, the LED flashed.

# Maintenance

---

1. Cabinet Cleaning:
  - a. The product should be maintained and cleaned periodically with power supply disconnected. when cleaning, use mild-rinsing water or non-corrosive products. Do not wash directly with water faucet.
  - b. Clean outside of unit using a soft cloth with neutral detergent, and dry with a separate soft cloth.
  - c. Clean inside racks by removing them from the unit and clean with water.
2. When shutting down unit for a long period of time, take out all food and unplug wall socket. Clean inside and outside thoroughly, and keep door open to sufficiently dry.
3. As glass breaks easily, keep far away from children.
4. Replacement of Lamp in Light Box: If the LED lamp is damaged, it must be replaced by Omcan or its service agent.
5. Frequently observe the operation of the product. In case of any abnormal noise or smell, cut off the power supply immediately and call professionals. Do not restart the product before source of trouble is found.
6. We will not be responsible for any accidents acquired through failure to follow previous notices

## CAUTIONS

- Minimizing time the time and frequency that the door is open will maintain temperature.
- Never block the air outlet and suction to keep the air circulation and refrigeration capability constant.
- Do not overfill refrigerator with food, as it will influence the cooling effect. If needed, adjust the rack height for proper food storage.
- Cool down hot food to room temperature before placing inside the refrigerator.
- During power interruptions, reduce opening times and maintain cool temperature in refrigerator.
- To avoid scalding, never touch the compressor.
- If the supply cord is damaged, it must be replaced by the manufacturer, its service agent, or similarly qualified persons in order to avoid hazard.
- This appliance is not intended for use by persons (including children) with reduced physical, sensory or mental capabilities, or lack of experience and knowledge, unless they have been given supervision or instruction concerning use of the appliance by a person responsible for their safety.
- Children should be supervised to ensure that they do not play with the appliance.

**WARNING:** Keep ventilation openings clear of obstructions.

**WARNING:** Do not use mechanical devices of other means to accelerate the defrosting process, other than those recommended by the manufacturer.

**WARNING:** Do not damage the refrigerant circuit.

**WARNING:** Do not use electrical appliances inside the food storage compartments of the appliance, unless they are of the type recommended by the manufacturer.



# Troubleshooting

Trouble	Cause and Remedy
No Refrigeration	Is the plug fitting in the socket?
	Is the fuse broken?
	Is there no power?
Unsatisfactory Refrigeration	Is it under sunshine? Is there any heat source nearby?
	Is the surrounding ventilation poor?
	Is the door closed? Is the door open for a long period of time?
	Is the door seal strip deformed or damaged?
	Is there too much food?
	Does food block the air suction or outlet?
	Regulate the temperature controller.
Noisy	The refrigerator is not level.
	The refrigerator contacts the wall or other matter.
	There is loose part in refrigerator.
Contact Omcan for help if simple troubleshooting does not solve the problems.	

## NOTE

### Following occurrences are not problems:

- The murmur of water is heard when the refrigerator is working. It is a normal occurrence as the coolant is circulating in the system.
- When the weather is damp, condensation might be found on the outside of the refrigerator. It is caused by high humidity. Simply use cloth to wipe it off.

## REFERENCE

Item Number	Model Number	Description	Manufacturer Model Number
39539	RS-CN-0270	Refrigerated Showcase Floor 270 L / 9.5 cu ft Curved 110V/60/1 CE	ARC270Y
40519	RS-CN-0370	Refrigerated Showcase Floor 370 L / 13 cu ft Curved 110V/60/1 CE	ARC370Y
39540	RS-CN-0370-S	Refrigerated Showcase Floor 370 L / 13 cu ft Square 110V/60/1 CE	ARC370Z

# Parts Breakdown

Model RS-CN-0270 39539

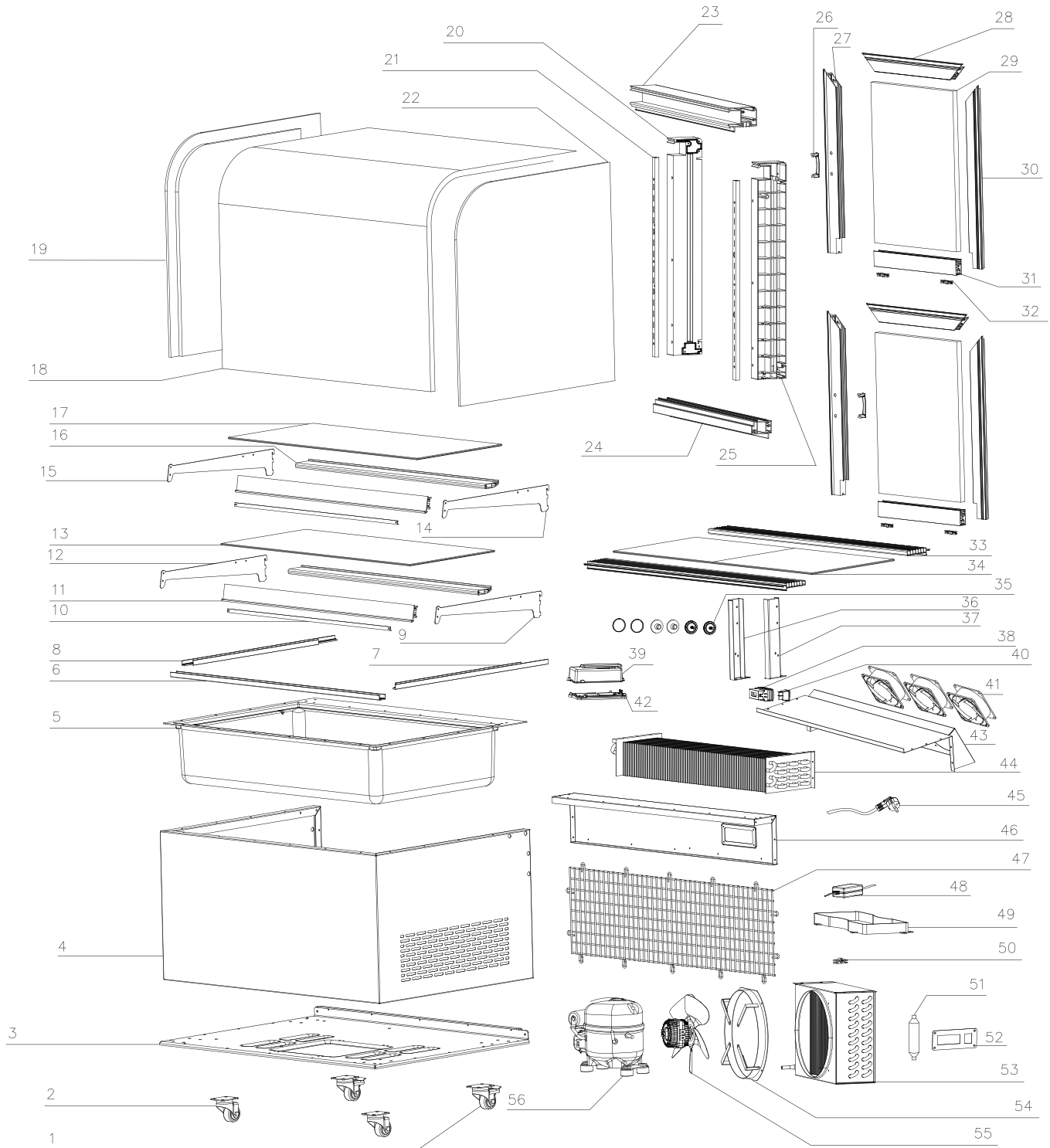



# Parts Breakdown

## Model RS-CN-0270 39539

Item No.	Description	Position	Item No.	Description	Position	Item No.	Description	Position
71042	Rear Swivel Caster with Brake for ARC270Y	1	71153	Shelf Holder for ARC270Y	21	71080	Switch for ARC270Y	40
79763	Swivel Front Caster without Brake for ARC270Y	2	71062	Right Arc Glass for ARC270Y	22	71081	Evaporator Motor for ARC270Y	41
71044	Bottom Plate for ARC270Y	3	64746	Top Frame for ARC270Y	23	71082	Thermostat Base for ARC270Y	42
71045	Cover for ARC270Y	4	71064	Bottom Frame for ARC270Y	24	64747	Evaporator Cover for ARC270Y	43
71046	Evaporator Insulation for ARC270Y	5	71065	Right Pole for ARC270Y	25	71084	Evaporator for ARC270Y	44
71047	Front Glass Fixer for ARC270Y	6	71110	Door Handle for ARC270Y	26	71085	Power Cord for ARC270Y	45
71048	Right Glass Fixer for ARC270Y	7	71162	Left Door Frame for ARC270Y	27	71086	Rear Frame for ARC270Y	46
71049	Left Glass Fixer for ARC270Y	8	71068	Top Upper Door Frame for ARC270Y	28	71087	Back Grill for ARC270Y	47
41966	Right Bottom Shelf Holder for ARC270Y	9	71069	Door Glass for ARC270Y	29	64750	#4 LED Transformer for ARC270Y	48
71149	LED for ARC270Y	10	71113	Right Door Frame for ARC270Y	30	71089	Water Tray for ARC270Y	49
71052	Metal Price Tags for ARC270Y	11	71071	Bottom Door Frame for ARC270Y	31	71133	Power Cord Fixer for ARC270Y	50
71152	Left Bottom Shelf Holder for ARC270Y	12	71114	Door Glidewheel for ARC270Y	32	71083	Dryer Filter for ARC270Y	51
71054	Top or Bottom Glass Shelf for ARC270Y	13, 17	71073	Air In/Outlet for ARC270Y	33	77434	Control Panel for ARC270Y	52
71051	Right Top Shelf Holder for ARC270Y	14	71074	Bottom Black Glass Frame for ARC270Y	34	71135	Condenser for ARC270Y	53
41612	Left Top Shelf Holder for ARC270Y	15	71121	Screw Cover for ARC270Y	35	71136	Fan Bracket for ARC270Y	54
71057	Metal Shelf Support for ARC270Y	16	71171	Pole Fixer (Left) for ARC270Y	36	71137	Condenser Fan Motor for ARC270Y	55
64745	Arc Glass for ARC270Y	18	71077	Pole Fixer (Right) for ARC270Y	37	64748	Compressor for ARC270Y	56
71103	Left Arc Glass for ARC270Y	19	71123	Control for ARC270Y	38			
71164	Left Pole Cover for ARC270Y	20	71079	Thermostat Lid for ARC270Y	39			

# Parts Breakdown

Model RS-CN-0370 40519

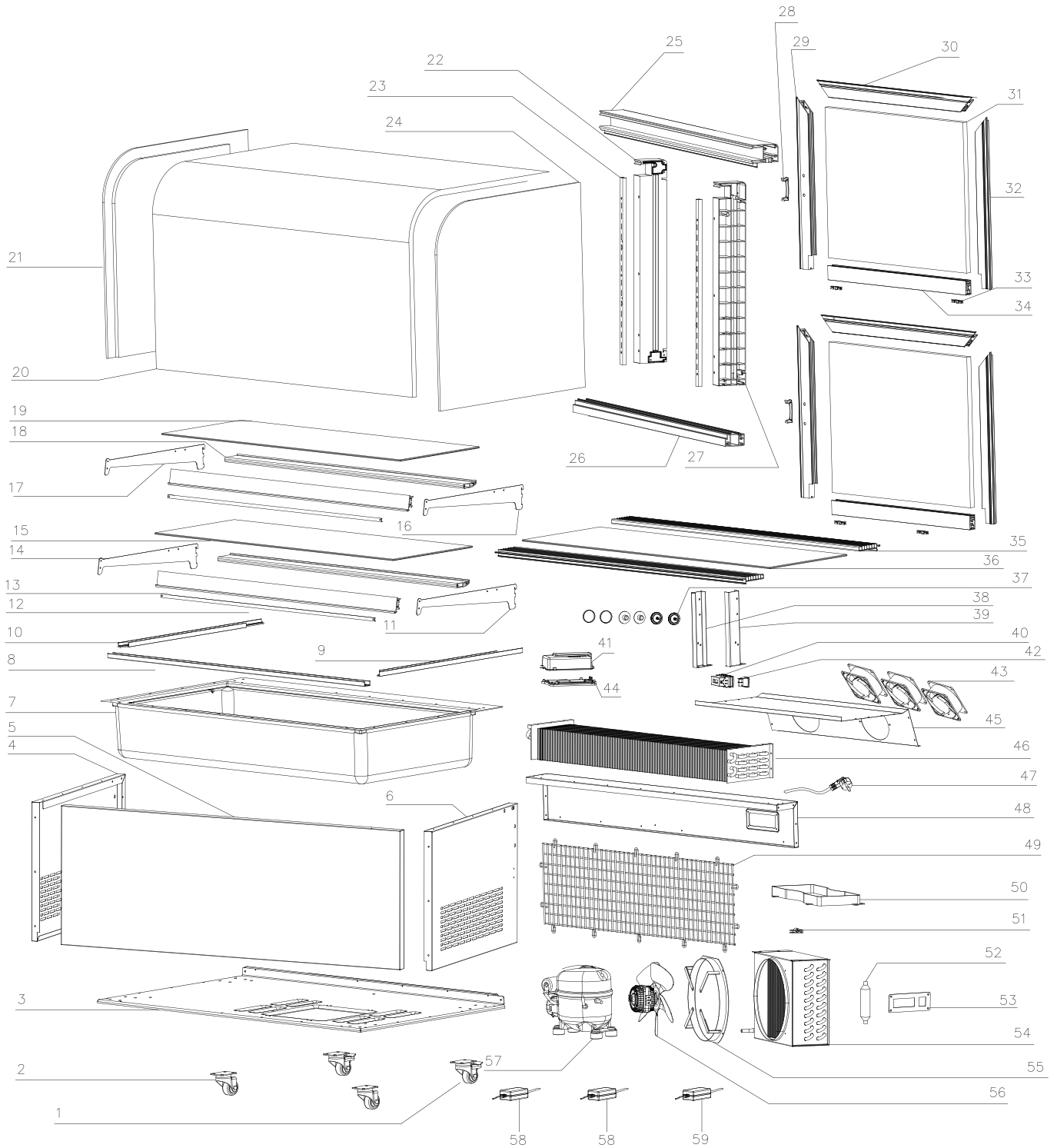



# Parts Breakdown

## Model RS-CN-0370 40519

Item No.	Description	Position	Item No.	Description	Position	Item No.	Description	Position
71042	Rear Swivel Caster with Brake for ARC370Y	1	71103	Left Arc Glass for ARC370Y	21	71079	Thermostat Lid for ARC370Y	41
79763	Swivel Front Caster without Brake for ARC370Y	2	71164	Left Pole Cover for ARC370Y	22	71080	Switch for ARC370Y	42
71092	Bottom Plate for ARC370Y	3	71157	Shelf Holder for ARC370Y	23	71081	Evaporator Motor for ARC370Y	43
71145	Left Cover for ARC370Y	4	71062	Right Arc Glass for ARC370Y	24	71082	Thermostat Base for ARC370Y	44
71166	Front Cover for ARC370Y	5	71104	Top Frame for ARC370Y	25	71126	Evaporator Cover for ARC370Y	45
71093	Right Cover for ARC370Y	6	71165	Bottom Frame for ARC370Y	26	71127	Evaporator for ARC370Y	46
71094	Evaporator Insulation for ARC370Y	7	71065	Right Pole for ARC370Y	27	71085	Power Cord for ARC370Y	47
71095	Front Glass Fixer for ARC370Y	8	71110	Door Handle for ARC370Y	28	71129	Rear Frame for ARC370Y	48
71048	Right Glass Fixer for ARC370Y	9	71162	Left Door Frame for ARC370Y	29	71130	Back Grill for ARC370Y	49
71049	Left Glass Fixer for ARC370Y	10	71111	Top Door Frame for ARC370Y	30	71089	Water Tray for ARC370Y	50
41966	Right Bottom Shelf Holder for ARC370Y	11	71112	Door Glass for ARC370Y	31	71133	Power Cord Fixer for ARC370Y	51
71149	LED for ARC370Y	12	71113	Right Door Frame for ARC370Y	32	71083	Dryer Filter for ARC370Y	52
71150	Metal Price Tags for ARC370Y	13	71114	Door Glidewheel for ARC370Y	33	77434	Control Panel for ARC370Y	53
71152	Left Bottom Shelf Holder for ARC370Y	14	71167	Bottom Door Frame for ARC370Y	34	71135	Condenser for ARC370Y	54
71100	Bottom Glass Shelf for ARC370Y	15	71119	Air In/Outlet for ARC370Y	35	71136	Fan Bracket for ARC370Y	55
71051	Right Top Shelf Holder for ARC370Y	16	79761	Bottom Black Glass Frame for ARC370Y	36	71137	Condenser Fan Motor for ARC370Y	56
41612	Left Top Shelf Holder for ARC370Y	17	71121	Screw Cover for ARC370Y	37	71139	Compressor for ARC370Y	57
64749	Metal Shelf Support for ARC370Y	18	71171	Pole Fixer (Left) for ARC370Y	38	64750	#4 LED Transformer for ARC370Y	58
71105	Top Glass Shelf for ARC370Y	19	71077	Pole Fixer (Right) for ARC370Y	39	64751	#2 LED Transformer for ARC370Y	59
71102	Arc Glass for ARC370Y	20	71123	Control for ARC370Y	40			

# Parts Breakdown

Model RS-CN-0370-S 39540

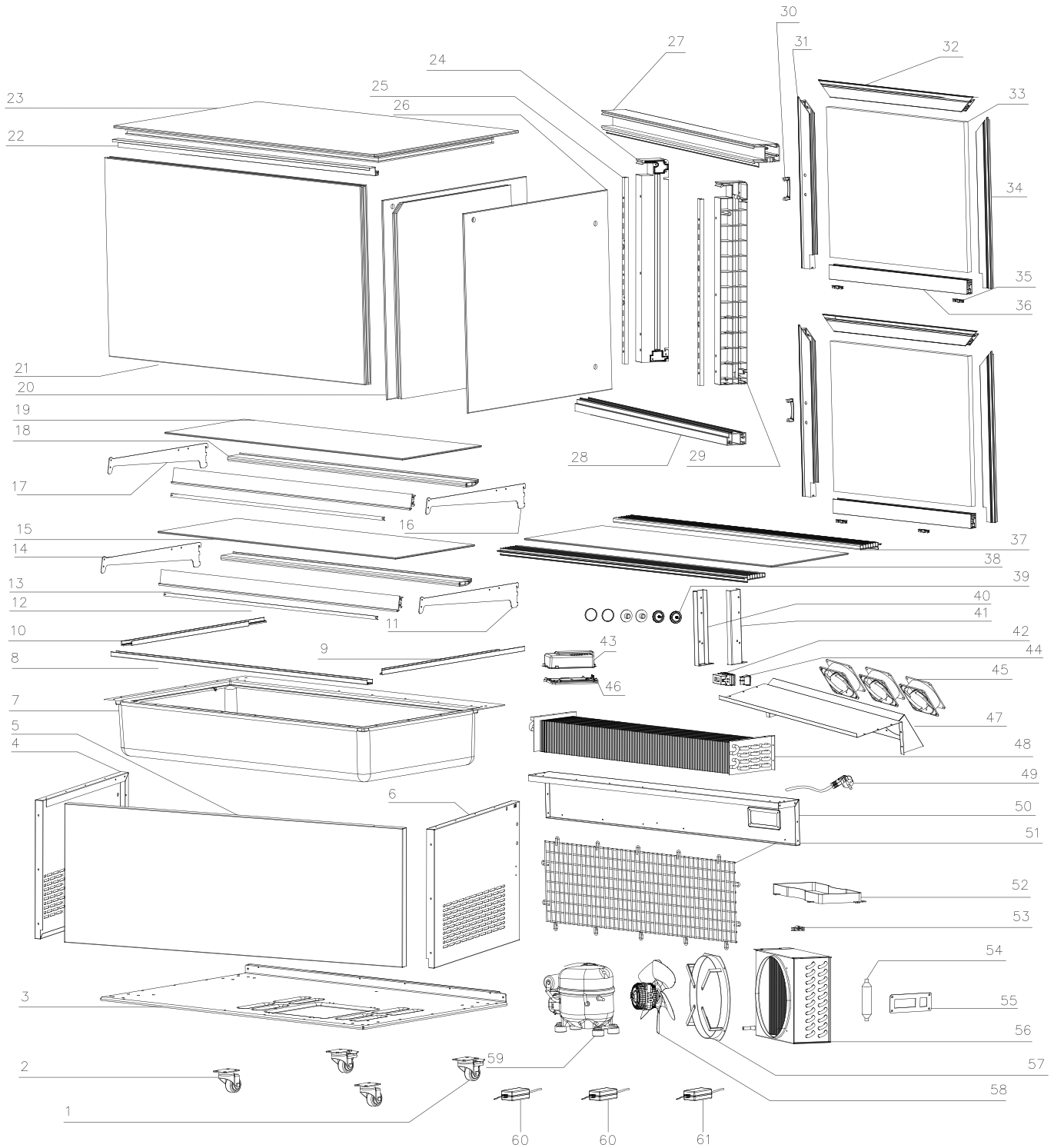



# Parts Breakdown

## Model RS-CN-0370-S 39540

Item No.	Description	Position	Item No.	Description	Position	Item No.	Description	Position
71042	Rear Swivel Caster with Brake for ARC370Z	1	79762	Front Upper Beam for ARC370Z	22	71079	Thermostat Lid for ARC370Z	43
71092	Swivel Front Caster without Brake for ARC370Z	2	79766	Top Glass for ARC370Z	23	71080	Switch for ARC370Z	44
71144	Bottom Plate for ARC370Z	3	71164	Left Pole Cover for ARC370Z	24	71081	Evaporator Motor for ARC370Z	45
71145	Left Cover for ARC370Z	4	71153	Shelf Holder for ARC370Z	25	71082	Thermostat Base for ARC370Z	46
71166	Front Cover for ARC370Z	5	64880	Right Glass for ARC370Z	26	71126	Evaporator Cover for ARC370Z	47
71093	Right Cover for ARC370Z	6	71104	Top Frame for ARC370Z	27	71127	Evaporator for ARC370Z	48
71094	Evaporator Insulation for ARC370Z	7	71165	Bottom Frame for ARC370Z	28	71085	Power Cord for ARC370Z	49
71095	Front Glass Fixer for ARC370Z	8	71156	Right Pole for ARC370Z	29	71178	Rear Frame for ARC370Z	50
71048	Right Glass Fixer for ARC370Z	9	71110	Door Handle for ARC370Z	30	71130	Back Grill for ARC370Z	51
71049	Left Glass Fixer for ARC370Z	10	71162	Left Door Frame for ARC370Z	31	71089	Water Tray for ARC370Z	52
41966	Right Bottom Shelf Holder for ARC370Z	11	71111	Top Door Frame for ARC370Z	32	71133	Power Cord Fixer for ARC370Z	53
71149	LED for ARC370Z	12	71112	Door Glass for ARC370Z	33	71083	Dryer Filter for ARC370Z	54
71150	Metal Price Tags for ARC370Z	13	71113	Right Door Frame for ARC370Z	34	77434	Control Panel for ARC370Z	55
71152	Left Bottom Shelf Holder for ARC370Z	14	71114	Door Glidewheel for ARC370Z	35	71135	Condenser for ARC370Z	56
71100	Bottom Glass Shelf for ARC370Z	15	71167	Bottom Door Frame for ARC370Z	36	71136	Fan Bracket for ARC370Z	57
71051	Right Top Shelf Holder for ARC370Z	16	71119	Air In/Outlet for ARC370Z	37	71137	Condenser Fan Motor for ARC370Z	58
41612	Left Top Shelf Holder for ARC370Z	17	79761	Bottom Black Glass Frame for ARC370Z	38	71187	Compressor for ARC370Z	59
64749	Metal Shelf Support for ARC370Z	18	71121	Screw Cover for ARC370Z	39	64750	#4 LED Transformer for ARC370Z	60
71105	Top Glass Shelf for ARC370Z	19	71171	Pole Fixer (Left) for ARC370Z	40	64751	#2 LED Transformer for ARC370Z	61
71155	Left Glass for ARC370Z	20	71077	Pole Fixer (Right) for ARC370Z	41			
71154	Front Glass for ARC370Z	21	71123	Control for ARC370Z	42			

# Electrical Schematics

Model RS-CN-0270 39539

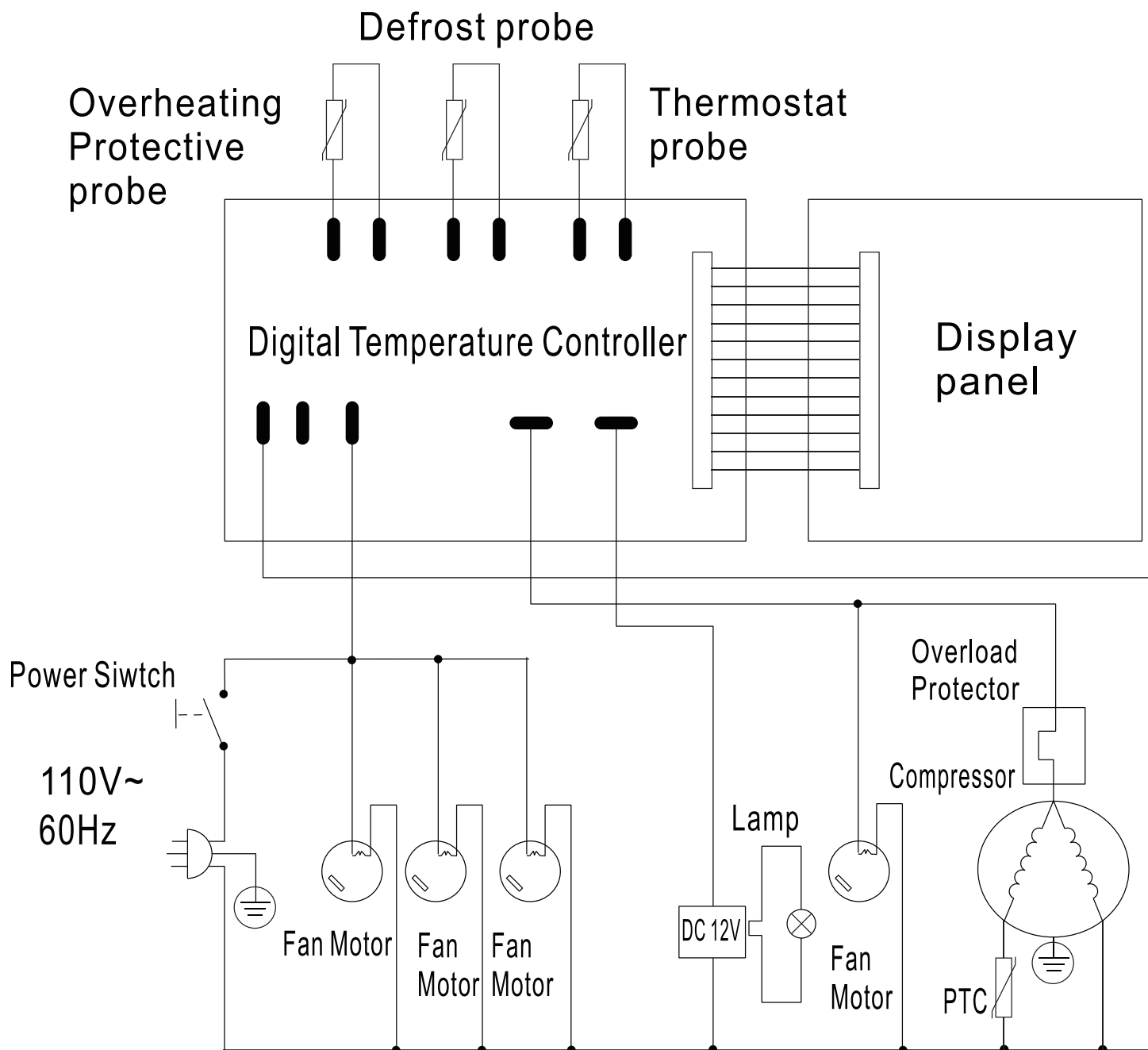



# Electrical Schematics

**Model RS-CN-0370** 40519

**Model RS-CN-0370-S** 39540

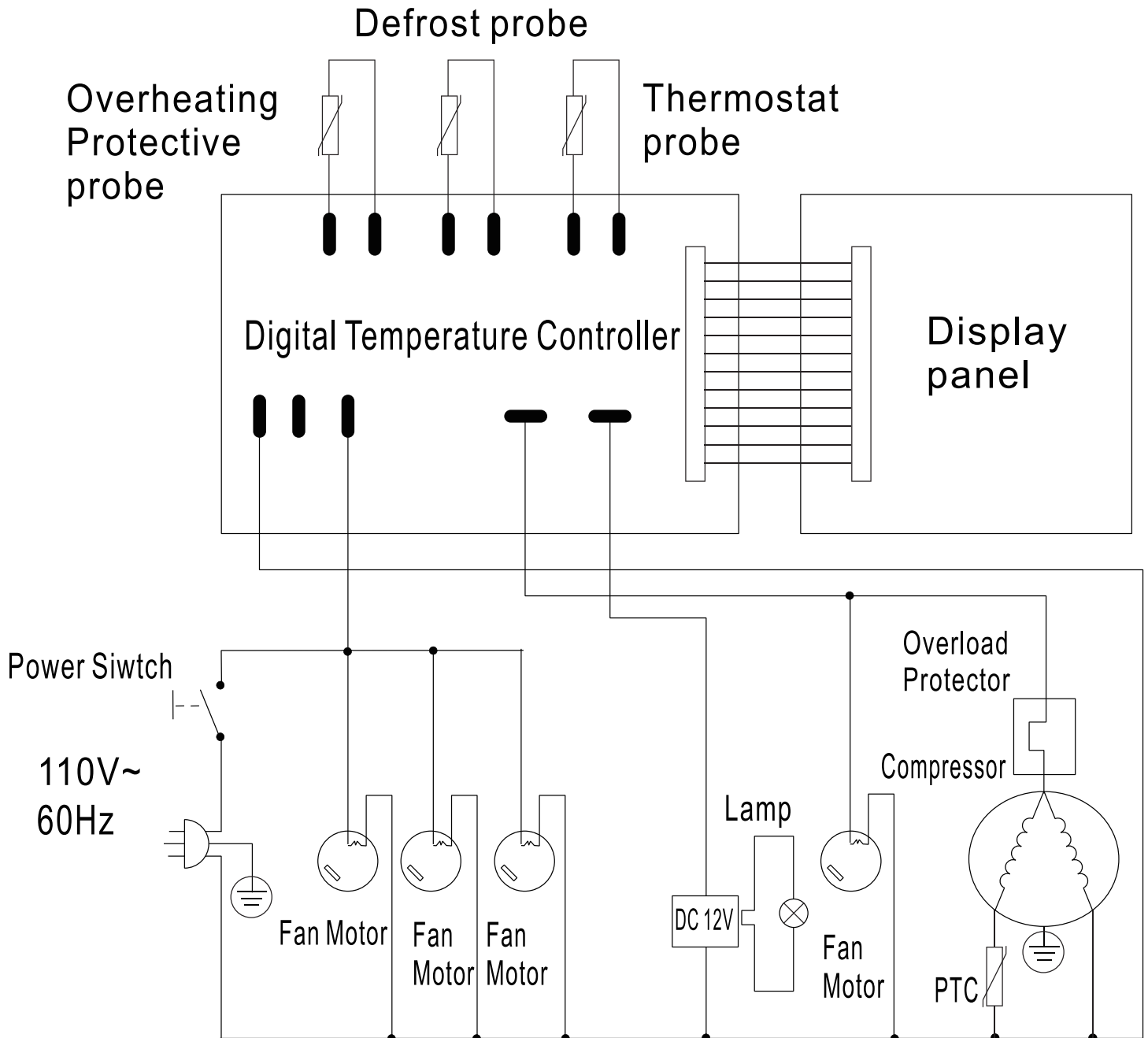





# Warranty Registration

Thank you for purchasing an Omcan product. To register your warranty for this product, complete the information below, tear off the card at the perforation and then send to the address specified below. You can also register online by visiting:

Merci d'avoir acheté un produit Omcan. Pour enregistrer votre garantie pour ce produit, complétez les informations ci-dessous, détachez la carte au niveau de la perforation, puis l'envoyer à l'adresse spécifiée ci-dessous. Vous pouvez également vous inscrire en ligne en visitant:

Gracias por comprar un producto Omcan usted. Para registrar su garantía para este producto, complete la información a continuación, cortar la tarjeta en la perforación y luego enviarlo a la dirección indicada a continuación. También puede registrarse en línea en:

**[www.omcan.com/warrantyregistration.html](http://www.omcan.com/warrantyregistration.html)**

**For mailing in Canada**

**Pour postale au Canada**

**Por correo en Canadá**

**For mailing in the US**

**Pour diffusion aux États-Unis**

**Por correo en los EE.UU.**

**OMCAN**

PRODUCT WARRANTY REGISTRATION

3115 Pepper Mill Court,

Mississauga, Ontario

Canada, L5L 4X5

**OMCAN**

PRODUCT WARRANTY REGISTRATION

4450 Witmer Industrial Estates, Unit 4,

Niagara Falls, New York

USA, 14305

**or email to: [service@omcan.com](mailto:service@omcan.com)**



**Purchaser's Information**

Name: \_\_\_\_\_

Company Name: \_\_\_\_\_

Address: \_\_\_\_\_

Telephone: \_\_\_\_\_

City: \_\_\_\_\_ Province or State: \_\_\_\_\_ Postal or Zip: \_\_\_\_\_

Email Address: \_\_\_\_\_

Country: \_\_\_\_\_

Type of Company:

Restaurant  Bakery  Deli

Butcher  Supermarket  Caterer

Institution (*specify*): \_\_\_\_\_

Other (*specify*): \_\_\_\_\_

Dealer from which Purchased: \_\_\_\_\_

Dealer City: \_\_\_\_\_ Dealer Province or State: \_\_\_\_\_

Invoice: \_\_\_\_\_

Model Name: \_\_\_\_\_ Model Number: \_\_\_\_\_

Serial Number: \_\_\_\_\_

Machine Description: \_\_\_\_\_

Date of Purchase (MM/DD/YYYY): \_\_\_\_\_

Date of Installation (MM/DD/YYYY): \_\_\_\_\_

Would you like to extend the warranty?  Yes  No

**Thank you for choosing Omcan | Merci d'avoir choisi Omcan | Gracias por elegir Omcan**



Since 1951 Omcan has grown to become a leading distributor of equipment and supplies to the North American food service industry. Our success over these many years can be attributed to our commitment to strengthen and develop new and existing relationships with our valued customers and manufacturers. Today with partners in North America, Europe, Asia and South America, we continually work to improve and grow the company. We strive to offer customers exceptional value through our qualified local sales and service representatives who provide convenient access to over 3,500 globally sourced products.

---

Depuis 1951 Omcan a grandi pour devenir un des “leaders” de la distribution des équipements et matériel pour l’industrie des services alimentaires en Amérique du Nord. Notre succès au cours de ces nombreuses années peut être attribué à notre engagement à renforcer et à développer de nouvelles et existantes relations avec nos clients et les fabricants de valeur. Aujourd’hui avec des partenaires en Amérique du Nord, Europe, Asie et Amérique du Sud, nous travaillons continuellement à améliorer et développer l’entreprise. Nous nous efforçons d’offrir à nos clients une valeur exceptionnelle grâce à nos ventes locales qualifiées et des représentants de service qui offrent un accès facile à plus de 3500 produits provenant du monde entier.

---

Desde 1951 Omcan ha crecido hasta convertirse en un líder en la distribución de equipos y suministros de alimentos en América del Norte industria de servicios. Nuestro éxito en estos años se puede atribuir a nuestro compromiso de fortalecer y desarrollar nuevas relaciones existentes con nuestros valiosos clientes y fabricantes. Hoy con socios de América del Norte, Europa, Asia y América del Sur, que trabajan continuamente para mejorar y crecer la empresa. Nos esforzamos por ofrecer a nuestros clientes valor excepcional a través de nuestro local de ventas y representantes de los servicios que proporcionan un fácil acceso a más de 3,500 productos con origen a nivel mundial.

