

PROJECT:	
MODEL # :	
ITEM # :	QTY :
AVAILABLE W/H :	APPROVAL :

Top Mount Reach-In Refrigerator / Freezer



BSR23T-HC / BSF23T-HC



BSR49T-HC / BSF49T-HC



BSR72T-HC / BSF72T-HC

STANDARD FEATURES

Cabinet construction

- Stainless steel cabinet construction
Stainless steel interior and exterior (galvanized steel back & bottom).
- Cyclopentane Insulation – Contains no hydro-fluorocarbons (HFCs) and is environmentally friendly
- Epoxy coated wire shelves with adjustable shelving height.
- 4 shelves per compartment
- Four (4) 4" Diameter swivel casters with front brakes standard. Six (6) casters on three-door models of which two (2) have front brakes.
- Designed to accept full size roll-in racks for bun sheet pan (18"L x 26"D)

Refrigeration

- Hydrocarbon refrigerants (R-290) – increases energy efficiency by up to 25% compared to using HFC refrigerants. It is safer for the environment and does not cause ozone depletion.
- Self-contained system, top mounted compressor.
- Electrodeposition coated evaporator increases performance by maintaining the heat transfer rates over the life of the evaporator and reducing potential corrosion.

- Air guard on rear wall ensures proper air circulation and cooling.
- Rear mounted condensation pan – No condensation pan assembly required. Designed to prevent water over flow and increase ventilation.
- Innovative hot gas frame heating system reduces condensation and increases energy efficiency.
- Refrigerators have a temperature range between 29°F ~ 39°F
Freezers hold a temperature range between 5°F and -10°F

Doors

- Self closing doors (doors close at 90° or less)
- Automatic hold open door feature at 110°
- Durable door gasket with easy replacement.
- Lifetime guaranteed heavy duty all metal door handles. (Ni-Cr Plated)
- Door designed to open easily.
Doors built with pressure relievers to eliminate vacuum pressure and allow easy door opening.
- Standard door locks

Design & Features

- Self-diagnostic digital temperature control & monitor system

- Digital display allows for easy monitoring
Digital controls include automatic evaporator fan motor delay.
- Rounded corner design gives a stylish appearance and reduces chances of injury.
- Visual and audible door open alarm, alarm sounds when doors are not completely closed to protect against food spoilage

Lighting

- LED Interior lighting.

Standard

- NSF/ANSI Standard 7 compliant

Connection

- 9 ft long flexible three wire cord with molded plug

Optional Features & Accessories

- 2.5" diameter casters available
- 6" adjustable feet available
- Left hinged door available for single door models
- Additional shelves are available.

Top Mount Reach-In Refrigerator / Freezer

PRODUCT PLAN VIEW

- Top View -

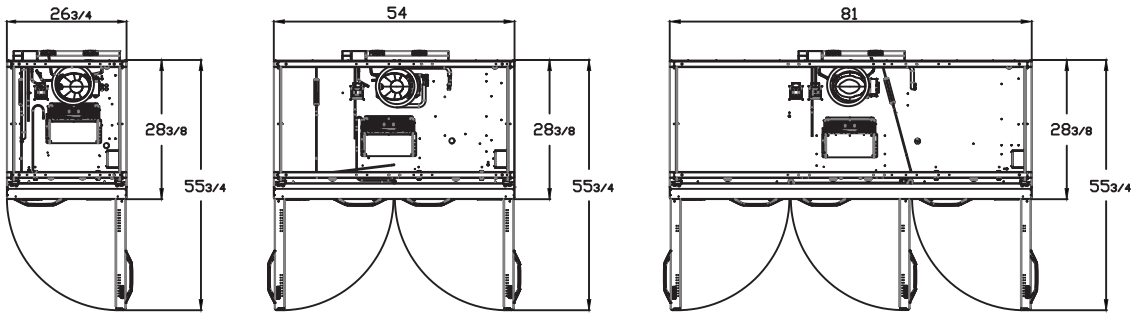

- Front View -

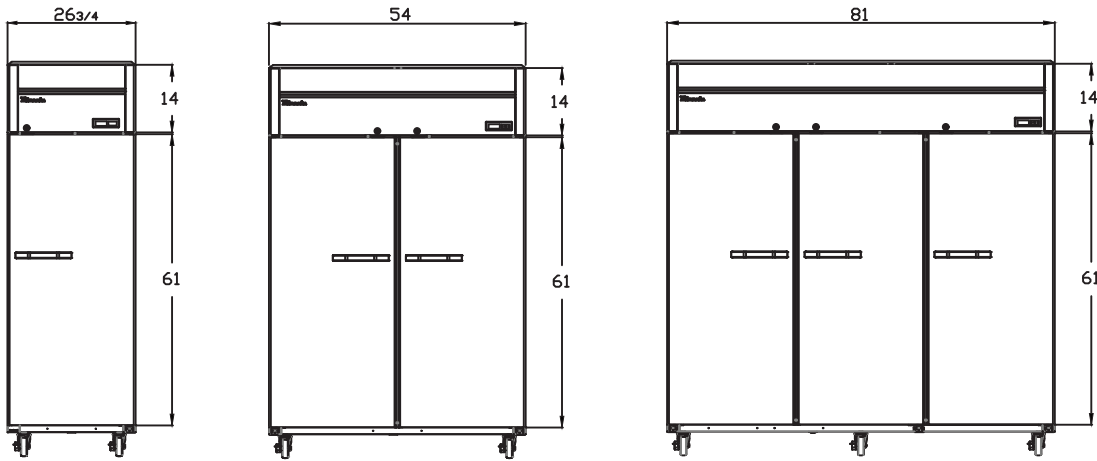

- Side View -

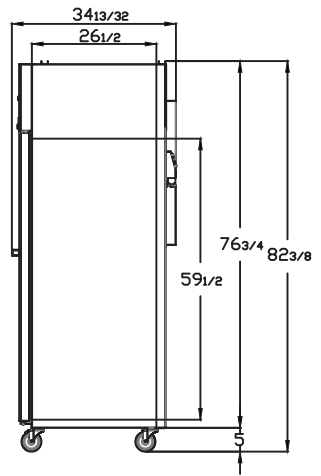

BSR23T-HC
BSF23T-HC

BSR49T-HC
BSF49T-HC

BSR72T-HC
BSF72T-HC

PRODUCT SPECIFICATION

Refrigerator

Model	Product Description			Refrigerant	Temperature Range	Easy Maintenance			Cord Length (ft/m)			
	Top Mount Refrigerator			R-290	29°F ~ 39°F	Sliding Condensing Unit			9.8ft (3m)			
	Doors	Capacity (Cu.Ft.)	Shelves	Cabinet Dimensions (inches / mm)			HP	Voltage	Amps	NEMA config.	Weight (lbs / kg)	
			L	D	H	Net Weight					Ship Weight	
BSR23T-HC	1	23	4	26 3/4" (681mm)	34 13/32" (874mm)	82 3/8" (2093mm)	1/4+	115V / 60Hz	3.0	NEMA 5-15	240 (109)	271 (123)
BSR49T-HC	2	49	8	54" (1372mm)	34 13/32" (874mm)	82 3/8" (2093mm)	1/4+	115V / 60Hz	3.2	NEMA 5-15	359 (163)	399 (181)
BSR72T-HC	3	72	12	81" (2057mm)	34 13/32" (874mm)	82 3/8" (2093mm)	1/2	115V / 60Hz	6.3	NEMA 5-15	531 (241)	595 (270)

Freezer

Model	Product Description			Refrigerant	Temperature Range	Easy Maintenance			Cord Length (ft/m)			
	Top Mount Freezer			R-290	-10°F ~ 5°F	Sliding Condensing Unit			9.8ft (3m)			
	Doors	Capacity (Cu.Ft.)	Shelves	Cabinet Dimensions (inches / mm)			HP	Voltage	Amps	NEMA config.	Weight (lbs / kg)	
			L	D	H	Net Weight					Ship Weight	
BSF23T-HC	1	23	4	26 3/4" (681mm)	34 13/32" (874mm)	82 3/8" (2093mm)	1/2	115V / 60Hz	4.9	NEMA 5-15	258 (117)	282 (128)
BSF49T-HC	2	49	8	54" (1372mm)	34 13/32" (874mm)	82 3/8" (2093mm)	1/2	115V / 60Hz	6.8	NEMA 5-15	390 (177)	428 (194)
BSF72T-HC	3	72	12	81" (2057mm)	34 13/32" (874mm)	82 3/8" (2093mm)	1	115V / 60Hz	8.4	NEMA 5-15	569 (258)	606 (275)

*BSR72T-HC is not energy star rated *BLUE AIR has the right to change specifications without further notice.