



Inferno Blaze Premium 36" Natural Gas 4 Burner Range with Oven with 12" Griddle - 148,000 BTU SKU: IBP-GR-3612/NG

- ★ **Efficient:** 148,000 BTU burners, NG Power Type
- ★ **Durable:** Stainless steel exterior
- ★ **Certified Safety:** ETL Listed, ETL Sanitation
- ★ **Powerful oven:** Single oven with 24,000 BTUs
- ★ **Powerful:** Four burners with 25,000 BTU each
- ★ **Griddle Size:** 12"
- ★ **Number Of Controls:** 5
- ★ **Casters:** Included, 6" size
- ★ **Spacious:** 36" width, 31" depth, and 56.4" height



Introducing the Inferno Blaze Premium IBP-GR-3612/NG, a powerhouse in culinary innovation. This 36" Natural Gas 4 Burner Range with Oven and a 12" Griddle is designed to elevate your kitchen experience with its exceptional features and robust performance, boasting an impressive 148,000 BTU.

Burner BTU	25,000
Caster Size (Inch)	6
Casters Included	Yes
Certifications	ETL Listed, ETL Sanitation
Color	Silver
Control Type	Manual
Exterior Material	Stainless steel
Gas Inlet Size (inch)	3/4
Griddle size	12
Number of Burners	4
Number Of Controls	5
Number of Ovens	1
Number Of Racks	1
Oven BTU	24,000
Power Type	NG
Shipping Weight (lbs)	583
Total BTU	148,000
Weight (lbs)	360

Crafted for efficiency and precision, each burner delivers a substantial 25,000 BTU, ensuring swift and even cooking. The 12" griddle adds versatility to your culinary repertoire, providing the perfect platform for creating delectable breakfast items or searing savory delights.

Constructed with durability in mind, the exterior of this culinary masterpiece is composed of high-quality stainless steel, presenting a sleek and professional appearance that stands up to the rigors of a bustling kitchen. The 6-inch casters, included for your convenience, make maneuvering this culinary workhorse a breeze.

Navigate your culinary creations effortlessly with the manual control type, offering five controls for precise command over your cooking environment. The gas inlet size of 3/4 inch ensures a steady and reliable fuel supply, while the natural gas power type optimizes performance.

Safety and compliance are at the forefront, as evidenced by ETL Listed and ETL Sanitation certifications. The single oven, equipped with one rack, operates at 24,000 BTU, adding another layer of functionality to this culinary marvel.

Item	Width (inch)	Depth (inch)	Height (inch)
Exterior	36	31	56.4

Certified Quality

ETL-certified, the Inferno Blaze guarantees quality and adheres to rigorous safety standards, offering peace of mind.

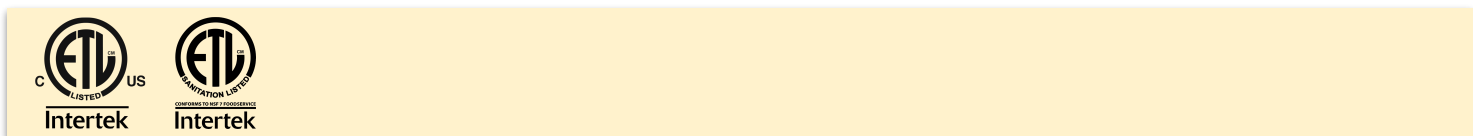

Kitchen Pro Restaurant Equipment: info@gokpe.com | www.kitchenproequipment.com | T. 1(800)603-0033

Note: Specifications subject to change without notice.

Not recommended for use in non-commercial or residential settings.

Technical Data:

FRONT VIEW

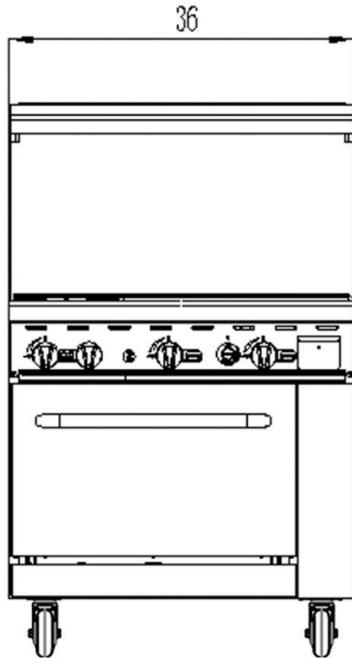

SIDE VIEW

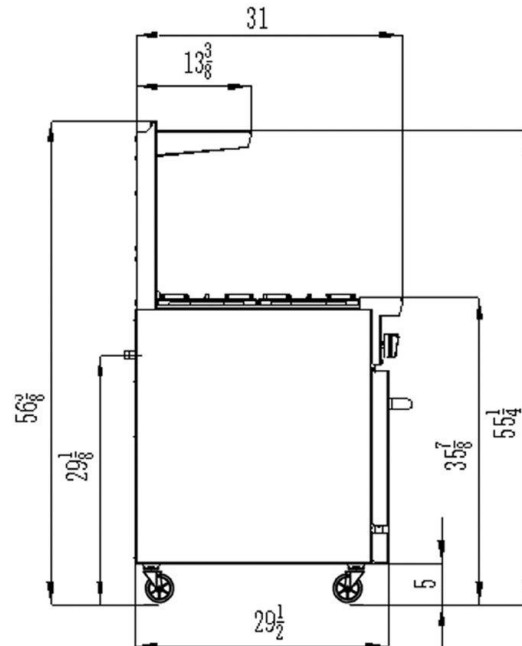

TOP VIEW

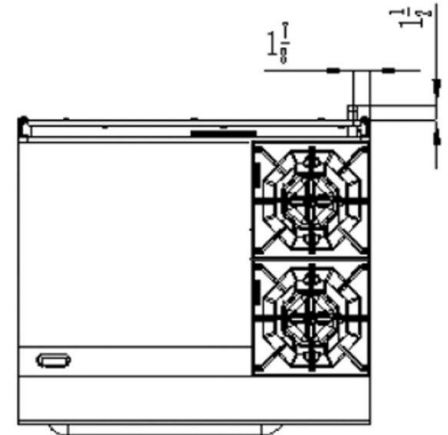

NG to LPG Conversion Kit Included!

This model is initially set up for Natural Gas use, but you can effortlessly switch it to a Liquid Propane configuration by replacing the N.G. orifices with L.P. orifices.

Upgrade your kitchen with the Inferno Blaze Premium IBP-GR-3612/NG, where innovation meets durability. Unleash the full potential of your culinary creations with this natural gas range, and discover a new standard of cooking excellence that blends performance and reliability seamlessly.

Warning: This product can expose you to chemicals including lead, which are known to the State of California to cause cancer, birth defects, or other reproductive harm. For more information, go to www.p65warnings.ca.gov.