

**INFERNO  
BLAZE**

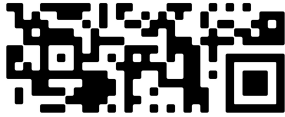

## Inferno Blaze Commercial Gas Range

36" Wide, 2 Burner Range, 24" Wide Manual Griddle with 1 Oven and Casters  
SKU: IB-GR-3624G

- ★ **Powerful Burners:** Two 30,000 BTU cast iron burners
- ★ **Versatile Griddle:** 24-inch steel griddle
- ★ **Certified Safety:** CSA-certified
- ★ **Field Convertible:** With included conversion kit
- ★ **Durable:** Stainless steel exterior
- ★ **Oven Interior Dimensions:** 22.5"D x 13.75"H x 26"W
- ★ **Wide Temperature Range:** Cooks from 200°F to 500°F



Unleash your culinary creativity with the Inferno Blaze IB-GR-3624G 36" Range, designed for chefs who demand excellence. This top-tier cooking appliance stands out with exceptional features and unmatched performance.

<b>Burner Type</b>	Cast Iron
<b>Burner BTU</b>	30,000
<b>Certifications</b>	CSA
<b>Clearance (inch)</b>	6
<b>Color</b>	Silver
<b>Control Type</b>	Manual
<b>Exterior Material</b>	Stainless Steel
<b>Gas Inlet Size (inch)</b>	3/4
<b>Griddle BTU</b>	30,000
<b>Griddle Width (inch)</b>	24
<b>Number of Burners</b>	2
<b>Number of Ovens</b>	1
<b>Oven BTU</b>	33,000
<b>Power Type</b>	Natural Gas
<b>Shipping Dimensions (inch)</b>	39.4 W X 36.6 D X 43.7 H
<b>Shipping Weight (lbs)</b>	467
<b>Weight (lbs)</b>	364

Discover the ultimate culinary companion for your commercial kitchen with the Inferno Blaze IB-GR-3624G 36" Range. This powerhouse combines open top burners, a 24" griddle, and a spacious oven to elevate your cooking experience.

Effortlessly perform a variety of cooking tasks, from boiling to sautéing and simmering, on the heavy-duty cast iron grates. The rugged steel griddle is perfect for grilling and more.

Additionally, the spacious oven offers a convenient way to warm your delectable dishes or even indulge in some dessert baking. With this natural gas range, culinary excellence is within your reach.

Item	Width (inch)	Depth (inch)	Height (inch)
<b>Exterior</b>	36	31.4	60
<b>Oven Cavity Size</b>	26	22.5	13.75

Number of Racks	Conversion Kit Included	Field Convertible
1	Yes	Yes

Temperature Range	Range Base Style	Casters
200°F to 500°F	Standard Oven	Included

### Certified Quality Assurance

CSA-certified, the Inferno Blaze guarantees quality and adheres to rigorous safety standards, providing unparalleled peace of mind.

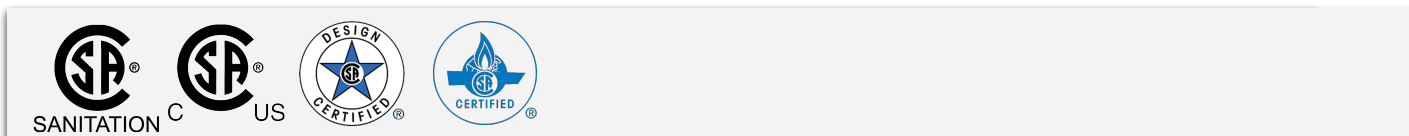

**Kitchen Pro Restaurant Equipment:** [info@gokpe.com](mailto:info@gokpe.com) | [www.kitchenproequipment.com](http://www.kitchenproequipment.com) | T.1(800)603-0033

Note: Specifications subject to change without notice.

Not recommended for use in non-commercial or residential settings.

## Technical Data:

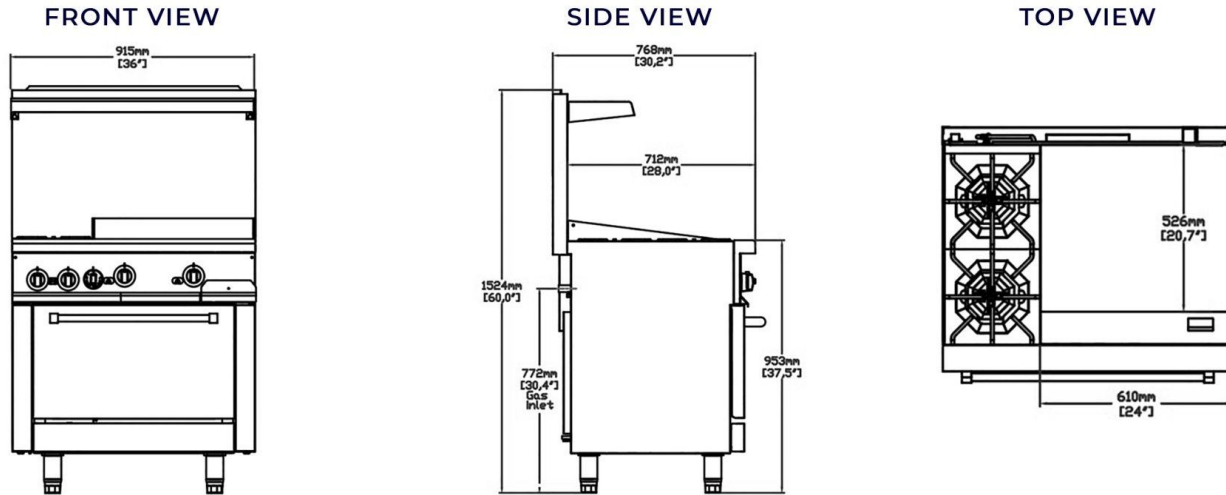

### Efficiency Elevated

Equipped with two cast iron burners, each boasting 30,000 BTU, this range swiftly reaches and maintains precise temperatures, ensuring culinary perfection..

### Ample Cooking Space

Generous dimensions of 31.4 inches in depth, 60 inches in height, and 36 inches in width accommodate your culinary creativity with ease.

### Versatile Cooking System

Featuring adaptable components, including a 24-inch wide manual steel griddle with 30,000 BTU burners, this range enables versatile cooking, delivering efficient results.

### Temperature Mastery

With a temperature range spanning from 200° F to 500°F, the Inferno Blaze IB-GR-3624G empowers you to excel in various culinary techniques.

### Built for Durability

Encased in sleek stainless steel, this range combines aesthetics with durability, withstanding the demands of professional kitchens.

### Freestanding Freedom

Its freestanding design simplifies installation and allows for versatile positioning in your kitchen.

### Double the Convenience

Equipped with two burners and one oven with interior dimensions of 22.5 inches in depth, 13.75 inches in height, and 20 inches in width, you can monitor your culinary creations without heat loss.

### Effortless Mobility

Casters offer convenient mobility for ease of cleaning or repositioning.

### Shipping Simplified

For your convenience, the range ships with dimensions of 39.4 inches in width, 36.6 inches in depth, and 43.7 inches in height.

Elevate your culinary craftsmanship with the Inferno Blaze IB-GR-3624G 36" Range – where convenience, quality, and performance converge to redefine your kitchen endeavors.

**Warning:** This product can expose you to chemicals including lead, which are known to the State of California to cause cancer, birth defects, or other reproductive harm. For more information, go to [www.p65warnings.ca.gov](http://www.p65warnings.ca.gov).