

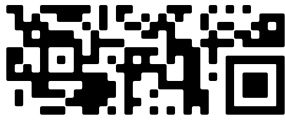

INFERNO  
BLAZE



## Inferno Blaze Commercial Gas Griddle 48" Wide Thermostatic Countertop Commercial Griddle | SKU: IB-CTG-48T

- ★ **Powerful Burners:** (4) 30,000 BTU burners
- ★ **Versatile Griddle:** 48-inch stainless steel griddle
- ★ **Certified Safety:** CSA-certified
- ★ **Convertible Design:** Field convertible with included conversion kit
- ★ **Durable Build:** Stainless steel exterior
- ★ **Spacious Cooking Area:** Cooking area dimensions: 48" x 20.7"
- ★ **Temperature Range:** 200°F to 450°F cooking versatility



Unleash culinary mastery with the Inferno Blaze IB-CTG-48T 48" Wide Thermostatic Countertop Commercial Griddle. This CSA-certified powerhouse delivers 120,000 BTUs, featuring a 4-Burner Cooktop with thermostatic controls for precise culinary control.

<b>BTU's</b>	90,000
<b>Certifications</b>	CSA
<b>Color</b>	Silver
<b>Control Type</b>	Thermostatic
<b>Cooking Area Dimensions (Inch)</b>	36W x 20.7D
<b>Exterior Material</b>	Stainless Steel
<b>Griddle Plate Thickness (Inch)</b>	1
<b>Installation Type</b>	Countertop
<b>Number of Burners</b>	3
<b>Number of Controls</b>	3
<b>Plate Material</b>	Stainless Steel
<b>Power Type</b>	Natural Gas
<b>Shipping Dimensions (inch)</b>	39.5 W x 35.5 D x 19.25 H
<b>Shipping Weight Certified Quality (lbs)</b>	338
<b>Weight (lbs)</b>	273

Experience culinary versatility with the Inferno Blaze IB-CTG-48T, a 48" wide natural gas griddle featuring 4 burners, a 48" thermostatic griddle plate, and precise temperature control. This kitchen powerhouse effortlessly handles grilling, searing, and cooking tasks with its stainless steel construction and heavy-duty components.

With 120,000 BTU of power, you can achieve exceptional results in your commercial kitchen. The thermostatic controls ensure accurate cooking temperatures ranging from 200°F to 450°F, perfect for various culinary creations. CSA-certified for safety, this countertop griddle is field convertible and includes a conversion kit for added convenience.

Elevate your culinary creations with the Inferno Blaze IB-CTG-48T, a reliable and versatile addition to your kitchen that's built to endure the demands of your culinary adventures.

Item	Width (inch)	Depth (inch)	Height (inch)
Exterior	36	28.7	15.5

Ignition System	Gas Inlet Size (inch)	Temperature Range	Field Convertible	Conversion Kit Included
Pilot Light	3/4	200°F to 450°F	Yes	Yes

CSA-certified, the Inferno Blaze guarantees quality and adheres to rigorous safety standards, offering peace of mind.

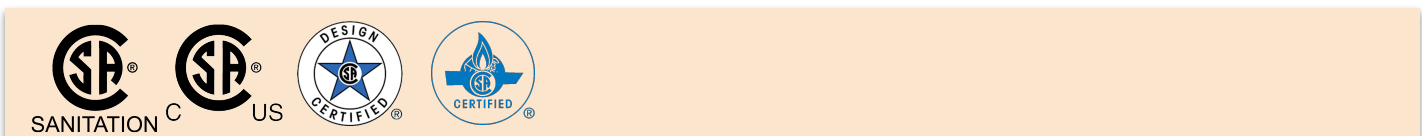

**Kitchen Pro Restaurant Equipment:** [info@gokpe.com](mailto:info@gokpe.com) | [www.kitchenproequipment.com](http://www.kitchenproequipment.com) | T. 1(800)603-0033

Note: Specifications subject to change without notice.

Not recommended for use in non-commercial or residential settings.

## Technical Data:

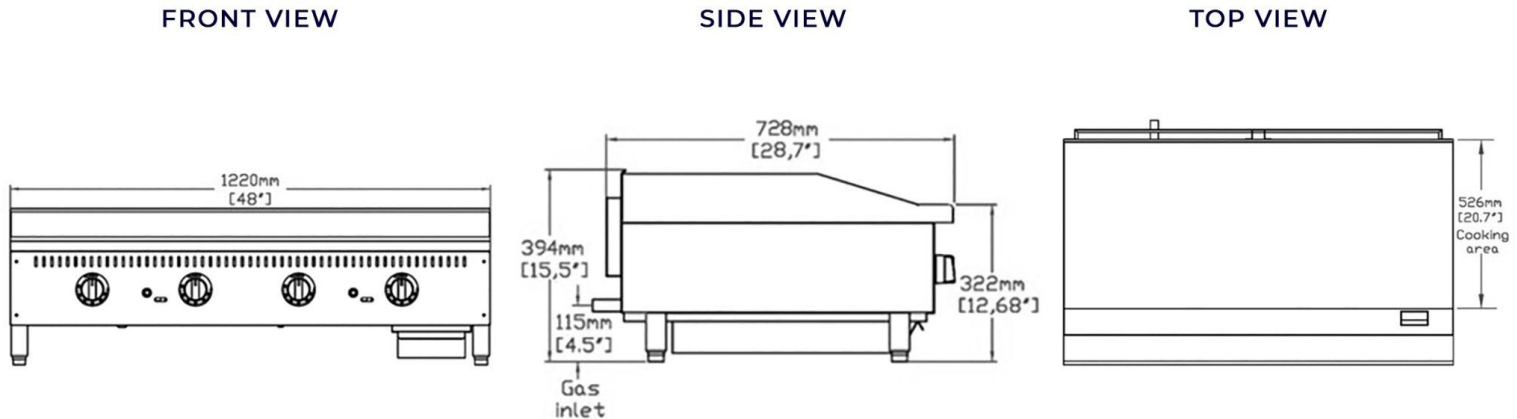

### Generous Cooking Space

With a vast 48 x 20.7-inch cooking area, ignite your culinary creativity with ample space.

### Built to Endure

Crafted with stainless steel, this griddle combines durability with aesthetics, thriving in the rigors of professional kitchens.

### Flexible Installation

The countertop design simplifies setup, offering kitchen flexibility to adapt to your needs seamlessly.

### Quadruple Cooking Convenience

Equipped with four burners, this griddle empowers multitasking without sacrificing precision, making it a culinary powerhouse.

### Effortless Mobility

Consider optional casters for effortless cleaning and repositioning, enhancing kitchen efficiency.

### Back and Side Splashes

Protect your walls and counters with back and side splashes, maintaining a safe and clean work environment.

### Rear Gas Connection

The 3/4" gas connection arrives ready to connect to a natural gas supply, and a liquid propane orifice kit is included for field conversion versatility.

### Convenient Waste Tray

This removable waste tray collects grease and food debris throughout the day, simplifying cleanup.

### Convenient Shipping

Ships with ease at dimensions of 51.25 inches in width, 35.5 inches in depth, and 19.25 inches in height.

Elevate your culinary journey with the Inferno Blaze IB-CTG-48T Griddle – where convenience, quality, and performance redefine your kitchen experience.

**Warning:** This product can expose you to chemicals including lead, which are known to the State of California to cause cancer, birth defects, or other reproductive harm. For more information, go to [www.p65warnings.ca.gov](http://www.p65warnings.ca.gov).