

**INFERNO
BLAZE**

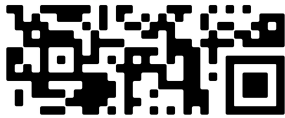

Inferno Blaze Commercial Gas Griddle 48" Wide Countertop Commercial Griddle with Manual Controls | SKU: IB-CTG-48M

- ★ **Powerful Burners:** (4) 30,000 BTU burners
- ★ **Versatile Griddle:** 48-inch stainless steel griddle
- ★ **Certified Safety:** CSA-certified
- ★ **Convertible Design:** Field convertible with included conversion kit
- ★ **Durable Build:** Stainless steel exterior
- ★ **Spacious Cooking Area:** Cooking area dimensions: 48" x 20.7"



Unlock culinary mastery with the Inferno Blaze IB-CTG-48M 48" Wide Countertop Commercial Griddle. This CSA-certified juggernaut wields an impressive 120,000 BTUs, featuring a 4-Burner Cooktop, ensuring precise temperature control for culinary perfection.

BTU's	120,000
Certifications	CSA
Color	Silver
Control Type	Manual
Cooking Area Dimensions (inch)	48W x 20.7D
Exterior Material	Stainless Steel
Griddle Plate Thickness (inch)	3/4
Installation Type	Countertop
Number of Burners	4
Number of Controls	4
Plate Material	Stainless Steel
Power Type	Natural Gas
Shipping Dimensions (inch)	51.25 W x 33.5 D x 19.25 H
Shipping Weight (lbs)	361
Weight (lbs)	284

Experience culinary versatility with the Inferno Blaze IB-CTG-48M, a 48" wide natural gas countertop griddle featuring 4 burners, a 48" stainless steel cooking area, and manual controls. This kitchen powerhouse effortlessly handles a variety of cooking tasks on its robust griddle, from frying and searing to grilling.

The griddle's 120,000 BTU ensures rapid and precise heating, allowing you to cook with efficiency. With its durable stainless steel construction, CSA certification, and included conversion kit, this griddle is designed for safety, durability, and adaptability in your commercial kitchen.

Elevate your culinary creations with this exceptional appliance, whether you're preparing breakfast, lunch, or dinner. Experience cooking convenience and quality with the Inferno Blaze IB-CTG-48M griddle.

Item	Width (inch)	Depth (inch)	Height (inch)
Exterior	48	28.7	15.4

Ignition System	Gas Inlet Size (inch)	Field Convertible	Conversion Kit Included
Pilot Light	3/4	Yes	Yes

Certified Quality

CSA-certified, the Inferno Blaze guarantees quality and adheres to rigorous safety standards, offering peace of mind.

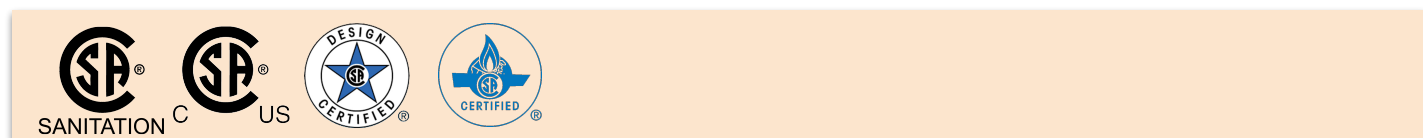

Kitchen Pro Restaurant Equipment: info@gokpe.com | www.kitchenproequipment.com | T. 1(800)603-0033

Note: Specifications subject to change without notice.

Not recommended for use in non-commercial or residential settings.

Technical Data:

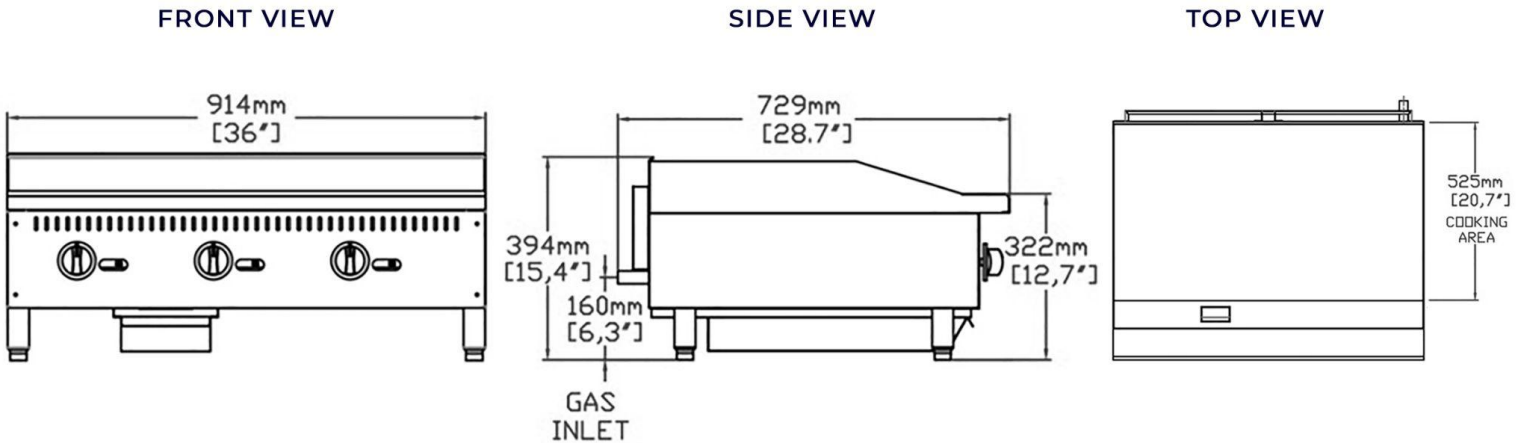

Spacious Cooking Realm

With an expansive 48 x 20.7 inch cooking area, ignite culinary creativity with generous space.

Built for Durability

Crafted from stainless steel, this griddle seamlessly blends durability with aesthetics, capable of enduring the demands of professional kitchens.

Installation Versatility

The countertop design simplifies setup and provides flexibility in kitchen layout.

Quad Cooking Convenience

Equipped with four burners, this griddle allows multitasking without compromising precision, perfect for culinary productivity.

Effortless Mobility

Consider optional casters for effortless cleaning and flexible positioning.

Back and Side Splashes

With back and side splashes to protect your walls and counters, you'll maintain a safe and clean work environment.

Rear Gas Connection

The 3/4" gas connection arrives ready to link to a natural gas supply, with a liquid propane orifice kit included for versatile field conversion.

Convenient Cleanup

A conveniently removable waste tray collects grease and food debris throughout the day, streamlining cleanup.

Shipping Made Easy

Ships with dimensions of 51.25 inches in width, 33.5 inches in depth, and 19.25 inches in height for your convenience.

Elevate your culinary journey with the Inferno Blaze IB-CTG-48M Griddle – where convenience, quality, and performance redefine your kitchen experience.

Warning: This product can expose you to chemicals including lead, which are known to the State of California to cause cancer, birth defects, or other reproductive harm. For more information, go to www.p65warnings.ca.gov.