

**INFERNO
BLAZE**

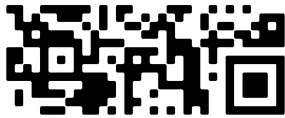

Inferno Blaze Commercial Gas Griddle 36" Wide Thermostatic Countertop Commercial Griddle | SKU: IB-CTG-36T

- ★ **Powerful Burners:** (3) 30,000 BTU burners
- ★ **Versatile Griddle:** 36-inch stainless steel griddle
- ★ **Certified Safety:** CSA-certified
- ★ **Convertible Design:** Field convertible with included conversion kit
- ★ **Durable Build:** Stainless steel exterior
- ★ **Spacious Cooking Area:** Cooking area dimensions: 36" x 20.7"
- ★ **Temperature Range:** 200°F to 450°F cooking versatility



Unlock culinary mastery with the Inferno Blaze IB-CTG-36T 36" Wide Thermostatic Countertop Commercial Griddle. This CSA-certified griddle boasts a commanding 90,000 BTU power, featuring a 3-Burner Cooktop with thermostatic controls, ensuring precise temperature control for culinary perfection.

BTU's	90,000
Certifications	CSA
Color	Silver
Control Type	Thermostatic
Cooking Area Dimensions (Inch)	36W x 20.7D
Exterior Material	Stainless Steel
Griddle Plate Thickness (Inch)	1
Installation Type	Countertop
Number of Burners	3
Number of Controls	3
Plate Material	Stainless Steel
Power Type	Natural Gas
Shipping Dimensions (inch)	39.5 W x 35.5 D x 19.25 H
Shipping Weight (lbs)	338
Weight (lbs)	273

Experience culinary versatility with the Inferno Blaze IB-CTG-36T, a 36" wide natural gas griddle featuring 3 burners, a thermostatic control system, and a spacious cooking area. This kitchen powerhouse allows you to effortlessly grill, sear, and fry on its rugged stainless steel griddle, providing diverse cooking options.

The griddle, with an impressive 90,000 BTU, offers precise temperature control ranging from 200°F to 450° F, ensuring exceptional results for your menu. Its durable stainless steel construction and CSA certification guarantee both longevity and safety, making it a valuable asset for your commercial kitchen.

Elevate your culinary creations with this exceptional appliance!

Item	Width (inch)	Depth (inch)	Height (inch)
Exterior	36	28.7	15.5

Ignition System	Gas Inlet Size (inch)	Temperature Range	Field Convertible	Conversion Kit Included
Pilot Light	3/4	200°F to 450° F	Yes	Yes

Certified Quality

CSA-certified, the Inferno Blaze guarantees quality and adheres to rigorous safety standards, offering peace of mind.

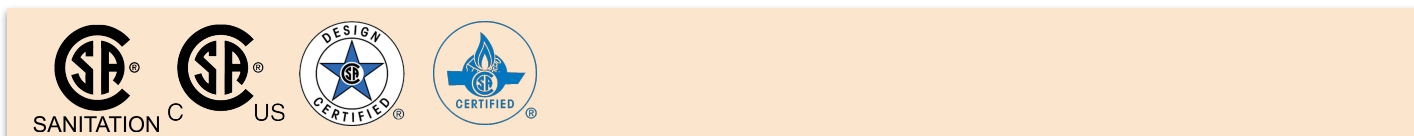

Kitchen Pro Restaurant Equipment: info@gokpe.com | www.kitchenproequipment.com | T. 1(800)603-0033

Note: Specifications subject to change without notice.

Not recommended for use in non-commercial or residential settings.

Technical Data:

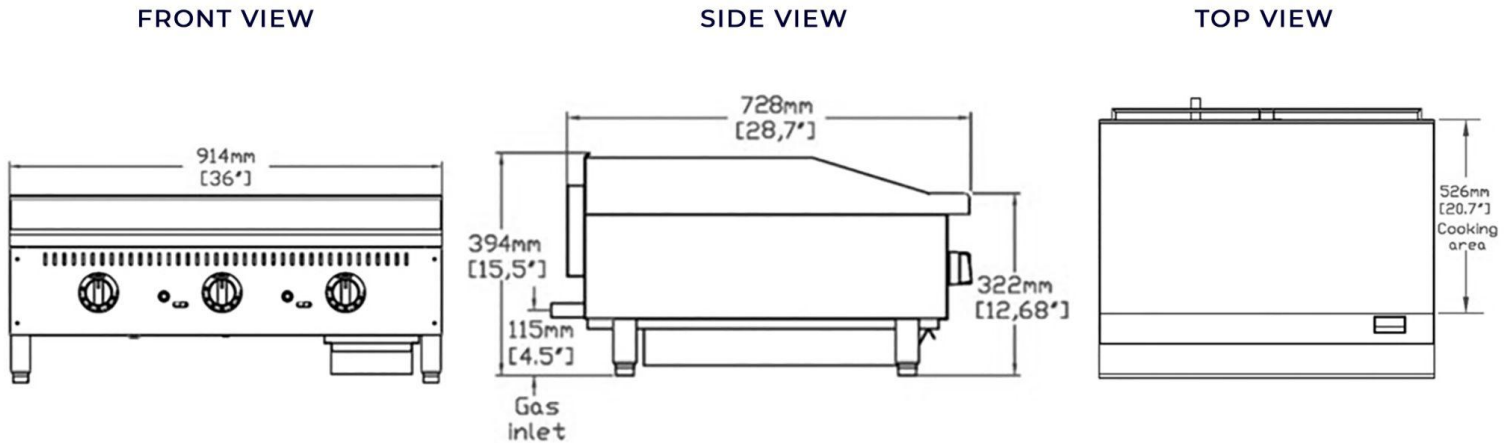

Ample Cooking Space

With a generous cooking area measuring 36 x 20.7 inches, you have the room to explore culinary creativity.

Built to Endure

Crafted with stainless steel, this griddle blends durability with aesthetics, enduring the rigors of professional kitchens.

Effortless Setup

The countertop design simplifies installation and offers kitchen flexibility to suit your needs.

Triple Cooking Convenience

Equipped with three burners, this griddle lets you multitask without sacrificing precision, making it a culinary powerhouse.

Enhanced Mobility

Consider optional casters for effortless cleaning and easy repositioning, improving kitchen efficiency.

Back and Side Protection

Back and side splashes protect your walls and counters, maintaining a safe and clean work environment.

Ready for Gas Connection

The 3/4" gas connection ships ready to connect to a natural gas supply. For added versatility, a liquid propane orifice kit is included for simple field conversion.

Efficient Waste Management

A conveniently removable waste tray collects grease and food debris throughout the day, making cleanup effortless.

Convenient Shipping

Ships at dimensions of 39.5 inches in width, 35.5 inches in depth, and 19.25 inches in height for your convenience.

Elevate your culinary journey with the Inferno Blaze IB-CTG-36T Griddle – where convenience, quality, and performance redefine your kitchen experience.

Warning: This product can expose you to chemicals including lead, which are known to the State of California to cause cancer, birth defects, or other reproductive harm. For more information, go to www.p65warnings.ca.gov.