

**INFERNO
BLAZE**

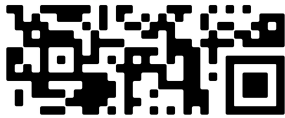

Inferno Blaze Commercial Gas Griddle 36" Wide Countertop Commercial Griddle with Manual Controls | SKU: IB-CTG-36M

- ★ **Powerful Burners:** (3) 30,000 BTU burners
- ★ **Versatile Griddle:** 36-inch stainless steel griddle
- ★ **Certified Safety:** CSA-certified
- ★ **Convertible Design:** Field convertible with included conversion kit
- ★ **Durable Build:** Stainless steel exterior
- ★ **Spacious Cooking Area:** Cooking area dimensions: 36" x 20.7"



Experience culinary excellence with the Inferno Blaze IB-CTG-36M 36" Wide Countertop Commercial Griddle. CSA-certified, this powerhouse delivers a remarkable 90,000 BTU of cooking power with a 3-Burner Cooktop, ensuring precise temperature control for culinary perfection.

BTU's	90,000
Certifications	CSA
Color	Silver
Control Type	Manual
Cooking Area Dimensions (inch)	36W x 20.7D
Exterior Material	Stainless Steel
Griddle Plate Thickness (inch)	3/4
Installation Type	Countertop
Number of Burners	3
Number of Controls	3
Plate Material	Stainless Steel
Power Type	Natural Gas
Shipping Dimensions (inch)	39.5 W x 33.5 D x 19.25 H
Shipping Weight (lbs)	285
Weight (lbs)	220

Experience culinary versatility with the Inferno Blaze IB-CTG-36M, a 36" wide natural gas griddle designed for your commercial kitchen. Boasting 90,000 BTUs of power distributed across three burners and a 36 x 20.7-inch cooking area, this griddle is a kitchen powerhouse. Its 3/4-inch stainless steel griddle plate and included conversion kit make it perfect for various cooking tasks.

Effortlessly control your cooking with manual controls and the pilot light ignition system. This countertop griddle is CSA-certified for safety. With a durable stainless steel exterior, adjustable non-skid legs, and field convertible design, it's built to endure and adapt to your kitchen's needs.

Elevate your culinary creations with the Inferno Blaze IB-CTG-36M and enjoy the freedom to grill, sauté, and more in your professional kitchen.

Item	Width (inch)	Depth (inch)	Height (inch)
Exterior	36	28.7	15.4

Ignition System	Gas Inlet Size (inch)	Field Convertible	Conversion Kit Included
Pilot Light	3/4	Yes	Yes

Certified Quality

CSA-certified, the Inferno Blaze guarantees quality and adheres to rigorous safety standards, offering peace of mind.



Kitchen Pro Restaurant Equipment: info@gokpe.com | www.kitchenproequipment.com | T. 1(800)603-0033

Note: Specifications subject to change without notice.

Not recommended for use in non-commercial or residential settings.

Technical Data:

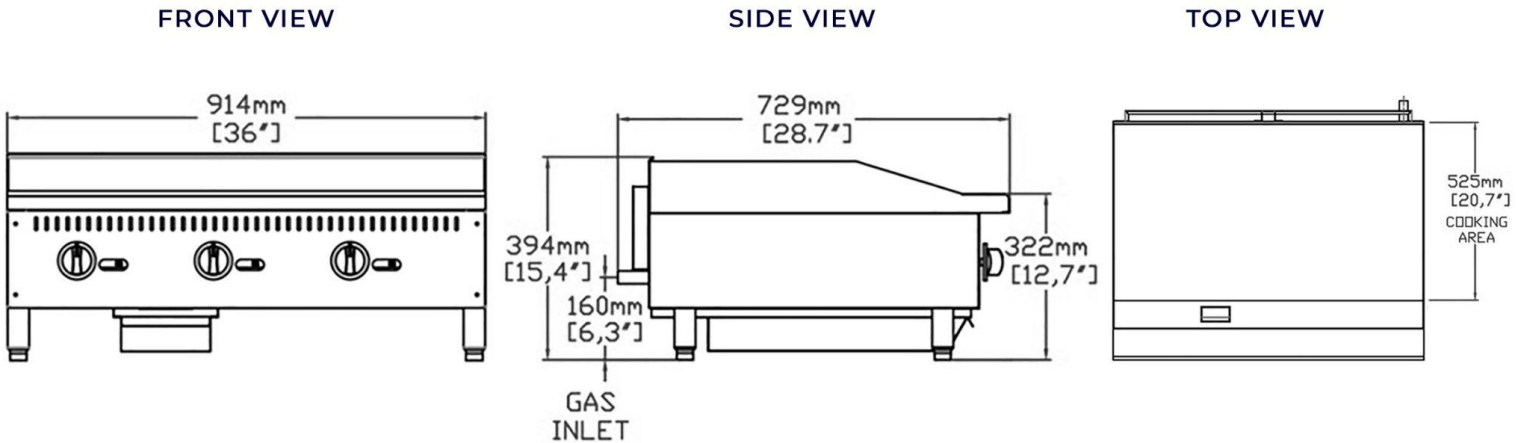

Spacious Cooking Area

Measuring 36 x 20.7 inches, this griddle offers ample space for culinary creativity.

Built for Durability

Crafted from stainless steel, this griddle blends durability and aesthetics, thriving in professional kitchens.

Easy Installation

The countertop design simplifies setup, offering kitchen flexibility tailored to your needs.

Triple Cooking Convenience

With three burners, multitask efficiently without compromising precision.

Effortless Mobility

Enhance kitchen efficiency with optional casters for effortless cleaning and repositioning.

Back and Side Splashes

With back and side splashes to protect your walls and counters, you'll maintain a safe and clean work environment.

Versatile Gas Connection

The 3/4" gas connection is ready for natural gas supply, and a liquid propane orifice kit is included for field conversion versatility.

Waste Tray

A conveniently removable waste tray collects grease and food debris throughout the day, simplifying cleanup.

Convenient Shipping

Ships at dimensions of 39.5 inches in width, 33.5 inches in depth, and 19.25 inches in height for your ease.

Elevate your culinary journey with the Inferno Blaze IB-CTG-36M Griddle – where convenience, quality, and performance redefine your kitchen experience.

Warning: This product can expose you to chemicals including lead, which are known to the State of California to cause cancer, birth defects, or other reproductive harm. For more information, go to www.p65warnings.ca.gov.