

REFRIGERATOR MANUFACTURER
Turbo air
 more durable, efficient, beautiful

4184 E. Conant St.
 Long Beach, CA 90808
 Tel. 310-900-1000
 Fax. 310-900-1077
www.turboairinc.com

Project :	
Model # :	
Item # :	Qty :
Available W/H :	
Approval :	

Ice Cream Dipping Cabinets

Model : TIDC-70W(G)



TIDC-70W



TIDC-70G



**TIDC-70W
Back View**

≡ FEATURES & BENEFITS ≡

- **Locked-in temperature equal from top to bottom**
 New technology of the Cold Wall System eliminates temperature fluctuations throughout the top and bottom areas of the interior cabinet. No more melting ice cream above while freezing below. Scooping has never been easier.
- **LED lighting for interior canopy**
 Brighter and longer lasting LED light bulbs produce less heat, saving energy while maximizing its display effect. Independent on/off light switch equipped.
- **5 years cleaning-free condenser**
 1/5" condenser pin gaps and electrodeposition coating allow the condenser to stay clean and prevents it from becoming tarnished, further guaranteeing the durability of the condenser.
- **Efficient refrigeration system**
 Turbo Air's dipping cabinets are designed with oversized and balanced (CFC Free R-404A) refrigeration systems. These include efficient evaporators and condensers for faster freezing and greater efficiency.
- **Attractive contemporary design with curved glass front and top**
- **Sturdy, clean stainless steel shelves**
- **Manual defrost system**
- **PE coated removable magnetic frost shields**
 Provides fast and easy removal of accumulated frost on inside walls.
- **Standard plastic night covers for case opening**
- **Maintains -10°F ~ 8°F for the best in frozen ice cream preservation**



Model	# of Lids	# of Shelves	# of Night Covers	Capacity 3 Gallon(12Liter) cans		HP	AMPS	Crated Weight (lbs.)	L x D x H (inches)
				Total	Display - 12 Storage - 8				
TIDC-70W(G)	2	3	3	20		1	7.0	518	68 x 26 1/8 x 49 5/8

Ice Cream Dipping Cabinets

Model : TIDC-70W / TIDC-70G

ELECTRICAL DATA	
Voltage	115/60/1
Plug Type	Ⓜ NEMA 5-15P
Full Load Amperes	7.0
Compressor HP	1
Refrigerant	R-404A
DIMENSIONAL DATA	
Capacity (3gal. cans) Display / Storage	12 / 8
Ext. Length Overall (in.)	68 (1726mm)
Ext. Depth Overall (in.)	26 1/8 (663mm)
Ext. Height Overall (in.)	49 5/8 (1259mm)
# of Lids	2
# of Night Covers	3
# of Shelves	3
Net Weight (lbs.)	419
Gross Weight (lbs.)	518

Design and specifications subject to change without notice.
Actual shipping weight may differ due to extra packing materials for product protection.

■ **WARRANTY : 2 Year Parts and Labor Warranty
Additional 3 Year Warranty on Compressor**

- **These models are designed to operate in air conditioned environments where temperature and humidity are below 75°F and 55% relative humidity**
- **Place units away from direct sunlight, rapid air movement and extreme temperature changes**
- **White (W) and Lime (G) color exterior available**
- **2.5" dia. casters available (optional)**
- **Price tag holder available (optional)**

■ **OPTIONAL ACCESSORIES :**

- 2.5" caster, 1/2" diameter & 13 TPI: 30265H0100 (non-brake), 30265H0200 (w/ brake)
- Price tag holder w/ bracket: P0330D0300 (holder), P0306D1700 (bracket)

PLAN VIEW

(unit : inch)

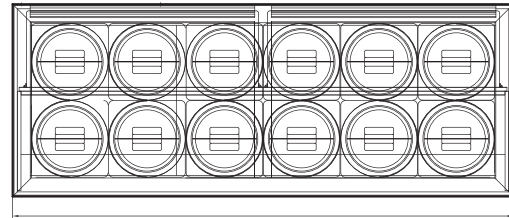

68 (1726mm)

PLAN VIEW

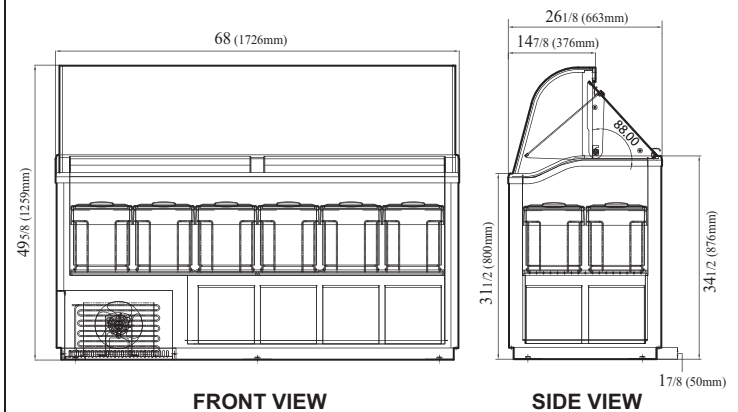

FRONT VIEW

SIDE VIEW

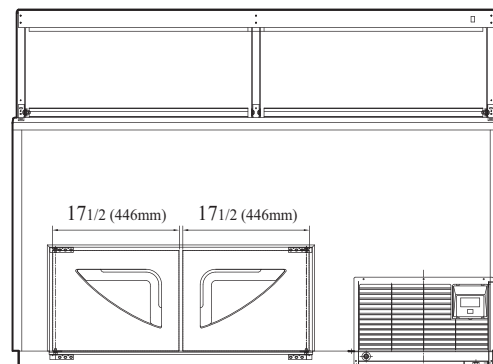

BACK VIEW

Ver.201701



- Turbo Air : 800-627-0032
- GK : 800-500-3519
- Warranty : 800-381-7770
- AC : 888-900-1002

REFRIGERATOR MANUFACTURER
Turbo air

GERMAN KNIFE

RADIANCE

GREEN WORLD

AIR CONDITIONER MANUFACTURER
Turbo air