



Frigos Value Series 2 Door Undercounter Freezer

SKU: FGV-UCFZ-60

- ★ Spacious: 14.1 cu ft capacity
- ★ Durable: Stainless steel exterior, painted aluminum interior
- ★ Efficient: Low energy usage (4.403 kW.h/24h)
- ★ Convenient: Self-closing doors, efficient LED lighting
- ★ Certified: ETL Electrical, ETL Sanitation, DOE
- ★ Maneuverable: Locking 5-inch casters
- ★ Powerful: 1/5 HP compressor
- ★ Sleek: Silver finish, swing-style solid doors



Refrigerant	R290
Horsepower (HP)	1/6
Voltage (V)	115
KW per 24h	1.097
Wattage (W) (W)	327
Weight (lbs)	66
Shipping Weight (lbs)	74
Door Self Closed	Yes
Interior Material	Painted Aluminum
Exterior Material	Stainless Steel
Color	Silver
Door Style	Swing
Door Type	Solid
Number of Doors	1
Compressor Location	Back Mounted
Plug Type	NEMA 5-15P
Casters	Included
Caster Size (inch)	5

Introducing our two-door commercial undercounter freezer, model FGV-UCFZ-60, meticulously designed to deliver exceptional performance and reliability for your commercial kitchen. This undercounter freezer is tailored to elevate your kitchen's capabilities, offering a spacious interior that expertly balances form and function.

With precise measurements of 61 inches in width, 30 3/8 inches in depth, and 38 3/8 inches in height, our commercial undercounter freezer provides generous storage space, boasting a capacity of 14.1 cubic feet. This makes it the perfect choice for accommodating all your frozen items while maintaining them at the optimal temperature.

Item	Width (Inch)	Depth (Inch)	Height (Inch)
Exterior	61	30 3/8	38 3/8
Interior	56	23 3/8	26 5/8

Capacity (Cu Ft)	Number of Shelves	Shelf Capacity (lbs)
14.1	2	85

- Robust Construction: Sturdy stainless steel exterior, pristine painted aluminum interior, and dependable 304 stainless steel floor.
- Ample Storage: Equipped with one epoxy-coated shelf, supporting up to 85 pounds.
- Superior Insulation: Boasts substantial 2-inch insulation for precise temperature control.
- High-Performance: Driven by a precise 1/5 HP compressor for top-tier reliability and efficiency.



Kitchen Pro Restaurant Equipment: info@gokpe.com | www.kitchenproequipment.com | T. 1-800-603-0033

Note: Specifications subject to change without notice.

Crafted with a robust stainless steel exterior and a clean, easy-to-maintain painted aluminum interior, this unit seamlessly combines durability with a hygienic and polished appearance. The substantial 2-inch insulation, using Cyclopentane, ensures excellent temperature control, preserving the freshness of your products.

Equipped with two sturdy shelves, each capable of supporting up to 85 pounds, you'll have ample space to efficiently organize your ingredients and items. The built-in LED lighting guarantees exceptional visibility, allowing you to quickly locate what you need.

Hinge Location	Amps (A)	Hertz (Hz)	Temperature Range
Right	4.5	60	-8°F to -1°F

The Frigos brand is renowned for quality, and this commercial undercounter freezer lives up to that reputation. Whether you're in the foodservice industry or managing a commercial kitchen, you can trust this unit to maintain the ideal temperature for your products, preserving their quality.

2 Door Undercounter Freezer SKU: FGV-UCFZ-60

The self-closing doors enhance convenience and save energy by ensuring a proper seal at all times. Maneuvering is effortless with four 5-inch casters providing stability and mobility.



Invest in the future of your business with our FGV-UCFZ-60 two-door undercounter freezer, perfectly suited for your freezing needs. It's a powerful, energy-efficient, and dependable addition to any kitchen, designed to meet your requirements for years to come. Explore our extensive selection of undercounter freezers, below counter fridge freezers, under worktop fridge and freezer units, and other equipment to streamline your kitchen operations. Elevate your kitchen with Frigos.

Technical Data:

FRONT VIEW

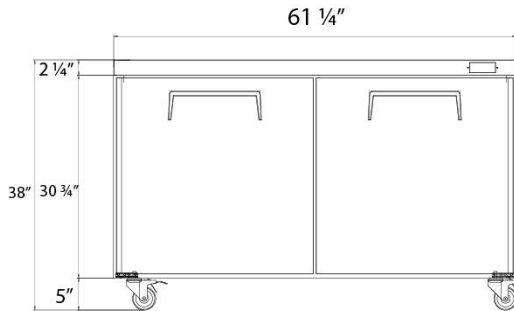

TOP VIEW

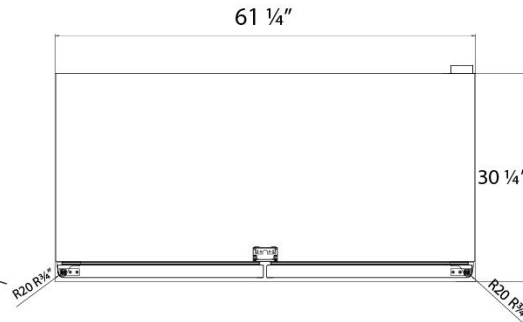

TOP VIEW

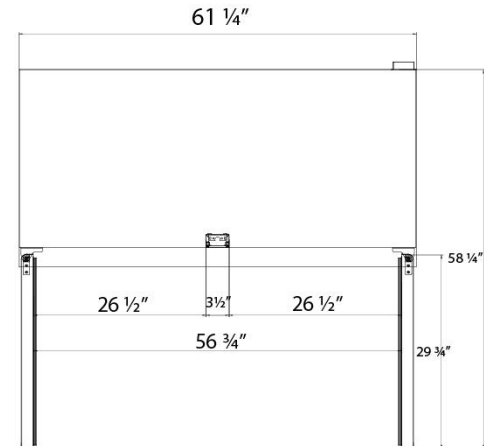

2 Door Undercounter Freezer SKU: FGV-UCFZ-60

Our FGV-UCFZ-60 undercounter freezer is certified by ETL Electrical, ETL Sanitation, and DOE, meeting essential health and safety standards. Its sleek silver finish and swing-style solid doors not only exude a professional appearance but also provide easy access to your frozen items.



Warning: This product can expose you to chemicals including lead, which are known to the State of California to cause cancer, birth defects, or other reproductive harm. For more information, go to www.p65warnings.ca.gov.