



## Frigos Value Series Two Door Undercounter Freezer

SKU: FGV-UCFZ-48

- ★ Spacious: 11.1 cu ft capacity
- ★ Durable: Stainless steel exterior, painted aluminum interior
- ★ Efficient: Low energy usage (4.183 kW/24h)
- ★ Convenient: Self-closing doors, efficient LED lighting
- ★ Certified: ETL Electrical, ETL Sanitation, DOE
- ★ Maneuverable: Locking 5-inch casters
- ★ Powerful: 1/5 HP compressor
- ★ Sleek: Silver finish, swing-style solid doors



Refrigerant	R290
Horsepower (HP)	1/6
Voltage (V)	115
KW per 24h	1.76
Wattage (W) (W)	327
Weight (lbs)	87
Shipping Weight (lbs)	97
Door Self Closed	Yes
Interior Material	Painted Aluminum
Exterior Material	Stainless Steel
Color	Silver
Door Style	Swing
Door Type	Solid
Number of Doors	2
Compressor Location	Back Mounted
Plug Type	NEMA 5-15P
Casters	Included
Caster Size (inch)	5

Introducing our two-door commercial undercounter freezer, model FGV-UCFZ-48, meticulously designed to provide exceptional performance and reliability for your commercial kitchen. This undercounter freezer is tailored to elevate your kitchen's capabilities, offering a spacious interior that perfectly balances form and function.

With precise measurements of 48 inches in width, 30 3/8 inches in depth, and 38 3/8 inches in height, our commercial undercounter freezer provides ample storage space, boasting a generous capacity of 11.1 cubic feet. This makes it an ideal choice for accommodating all your frozen items while maintaining them at the perfect temperature.

Item	Width (Inch)	Depth (Inch)	Height (Inch)
Exterior	48	30 3/8	38 3/8
Interior	43	23 3/8	26 5/8

Capacity (Cu Ft)	Number of Shelves	Shelf Capacity (lbs)
11.1	2	85

- **Robust Construction:** Sturdy stainless steel exterior, pristine painted aluminum interior, and dependable 304 stainless steel floor.
- **Ample Storage:** Equipped with one epoxy-coated shelf, supporting up to 85 pounds.
- **Superior Insulation:** Boasts substantial 2-inch insulation for precise temperature control.
- **High-Performance:** Driven by a precise 1/5 HP compressor for top-tier reliability and efficiency.



**Kitchen Pro Restaurant Equipment:** [info@gokpe.com](mailto:info@gokpe.com) | [www.kitchenproequipment.com](http://www.kitchenproequipment.com) | T. 1-800-603-0033

Note: Specifications subject to change without notice.

Crafted with a robust stainless steel exterior, a pristine painted aluminum interior, and a dependable 304 stainless steel floor, this unit seamlessly combines durability with a hygienic and clean appearance. The substantial 2-inch insulation, utilizing Cyclopentane, ensures impeccable temperature control, preserving the freshness of your frozen products.

The freezer features two sturdy shelves, each capable of supporting up to 85 pounds, providing you with the flexibility to organize your frozen ingredients and items efficiently. The built-in LED lighting guarantees exceptional visibility, ensuring you can quickly locate what you need.

Hinge Location	Amps (A)	Hertz (Hz)	Temperature Range
Right	4.7	60	-8°F to -1°F

Frigos, a trusted brand renowned for quality, proudly stands behind this commercial undercounter freezer. Whether you're in the foodservice industry or managing a commercial kitchen, you can rely on this unit to maintain the ideal temperature for your frozen products, preserving their quality.

## 2 Door Undercounter Freezer SKU: FGV-UCFZ-48

The self-closing doors enhance convenience and energy efficiency by ensuring a secure seal at all times, preventing temperature fluctuations. Maneuvering is effortless thanks to the four 5-inch casters that provide stability and mobility.



Invest in the future of your business with our FGV-UCFZ-48 two-door undercounter freezer, perfectly suited for your freezing needs. It's a powerful, energy-efficient, and dependable addition to any kitchen, designed to meet your requirements for years to come. Explore our extensive selection of undercounter freezers and other equipment to optimize your kitchen operations. Elevate your kitchen with Frigos.

## Technical Data:

FRONT VIEW

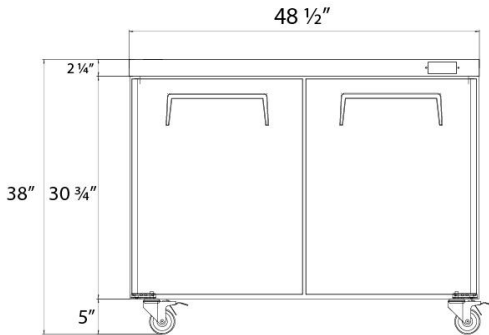

TOP VIEW

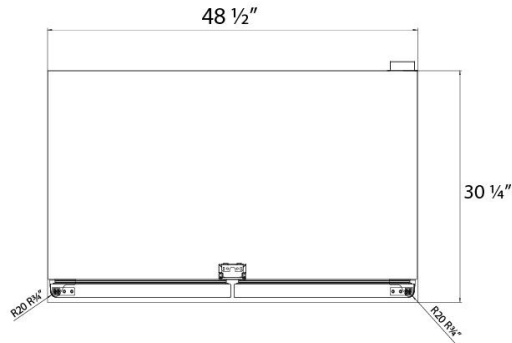

TOP VIEW

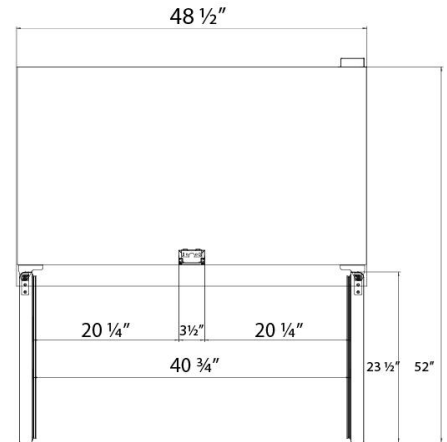

### 2 Door Undercounter Freezer SKU: FGV-UCFZ-48

Our FGV-UCFZ-48 undercounter freezer is certified by ETL Electrical, ETL Sanitation, and DOE, meeting essential health and safety standards. Its sleek silver finish and swing-style solid doors not only lend a professional appearance but also grant easy access to your frozen items.



**Warning:** This product can expose you to chemicals including lead, which are known to the State of California to cause cancer, birth defects, or other reproductive harm. For more information, go to [www.p65warnings.ca.gov](http://www.p65warnings.ca.gov).