



## Frigos Value Series 3 Door 72" Sand Prep Table

SKU: FGV-SWPT-72

- ★ Spacious: 22.3 cu ft capacity
- ★ Durable: Stainless steel exterior, painted aluminum interior
- ★ Efficient: Low energy usage (6.49 kWh/24h)
- ★ Convenient: Self-closing doors, efficient LED lighting
- ★ Certified: ETL Electrical, ETL Sanitation, DOE
- ★ Mobility: Locking casters
- ★ Powerful: 1/5 HP compressor



Refrigerant	R290
Horsepower (HP)	1/5
Voltage (V)	115V/60hz
KW per 24h	6.49kw.h/24h
Wattage	460
Weight (lbs)	170
Shipping Weight (lbs)	200
Door Self Closed	Yes
Interior Material	Painted Aluminum
Exterior Material	Stainless Steel
Color	Silver
Door Style	Swing
Door Type	Solid
Compressor Location	Rear Mounted
Shelf Capacity (lbs)	85
Plug Type	NEMA 5-15P

Introducing our 72" sandwich prep table, the Frigos FGV-SWPT-72, meticulously engineered to meet the rigorous demands of your commercial kitchen. With precise dimensions of 72 inches in width, 30 3/8 inches in depth, and 45 3/8 inches in height, this unit offers an expansive workspace for all your food preparation needs.

Crafted with a robust stainless steel exterior and a clean, easy-to-maintain painted aluminum interior, this prep table combines durability with impeccable hygiene standards. Boasting an impressive 22.3 cubic feet of storage capacity, complete with eighteen included pans, it's perfectly suited for sandwich and salad preparation.

Item	Width (Inch)	Depth (Inch)	Height (Inch)
Exterior	72	30 3/8	45 3/8
Interior	67 3/4	25 3/8	28 3/4

Capacity (Cu Ft)	Number of Shelves	Number of Doors
22.3	3	3

- **Crafted:** Sturdy stainless steel exterior, clean painted aluminum interior, and a dependable 304 stainless steel floor.
- **Storage:** Ample with epoxy-coated shelf, supports up to 85 pounds.
- **Insulation:** Superior with substantial 2-inch insulation for precise temperature control.
- **Performance:** High-powered by a 1/5 HP compressor, ensuring top-tier reliability and efficiency.

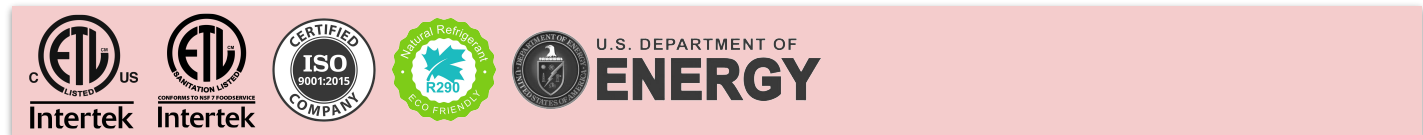

The Frigos Value Series FGV-SWPT-72 is engineered for energy efficiency, featuring a 1/5 HP compressor operating at 115V/60Hz and utilizing environmentally friendly R290 refrigerant. It's designed to minimize energy consumption, with operating costs as low as 6.49 kW.h/24h, ensuring long-term savings for your business.

This unit's three solid doors, all reversible for convenience and energy efficiency, maintain a secure seal to preserve the freshness of your ingredients. Inside, you'll find three robust shelves, each with a remarkable 85-pound capacity. Integrated LED lighting guarantees optimal visibility during food preparation.

Hinge Location	Amps	Hertz	Temperature Range
left/right/right	5.2A	60Hz	33°F to 40°F
Phase	Shelves Size	Shelf Capacity (lbs)	Caster Size (Inch)
Single-phase	20.8 x 19	85	5"

Elevate your commercial kitchen with the Frigos Value Series FGV-SWPT-72 sandwich prep table. Whether you're in the foodservice industry or managing a restaurant, this prep table ensures your ingredients remain fresh and at the right temperature, preserving their quality.

### 3 Door 72" Sandwich Prep Table SKU: FGV-SWPT-72

Certified by ETL Electrical, ETL Sanitation, and DOE, the FGV-SWPT-72 adheres to essential health and safety standards. Its sleek silver finish and swing-style solid doors not only convey a professional appearance but also provide effortless access to your ingredients.



Invest in the future of your business with the Frigos Value Series FGV-SWPT-72. It's a powerful, energy-efficient, and reliable addition to any kitchen, designed to meet your needs for years to come. Explore our range of prep tables and kitchen equipment to optimize your operations. Choose Frigos for quality and performance.

## Technical Data:

FRONT VIEW

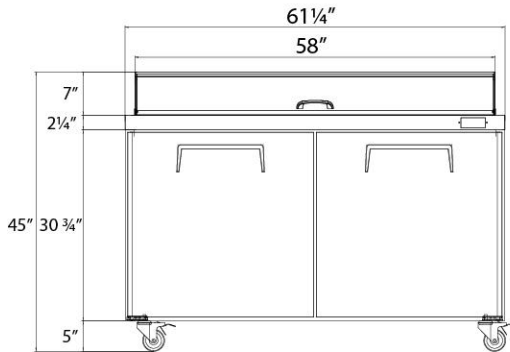

TOP VIEW

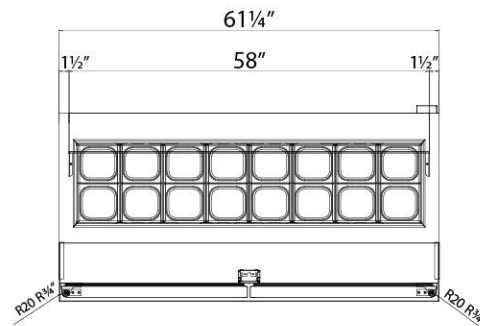

TOP VIEW

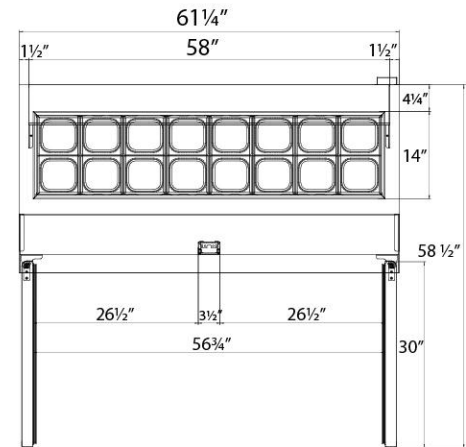

### 3 Door 72" Sandwich Prep Table SKU: FGV-SWPT-72

The self-closing door adds convenience and saves energy by ensuring a proper seal at all times. Moving it around is effortless with four 5-inch casters that provide stability and mobility.



**Warning:** This product can expose you to chemicals including lead, which are known to the State of California to cause cancer, birth defects, or other reproductive harm. For more information, go to [www.p65warnings.ca.gov](http://www.p65warnings.ca.gov).