



Frigos Value Series Two Door Reach-In Refrigerator

SKU: FGV-RF-2D

- ★ Spacious: 47.30 cu ft capacity
- ★ Durable: Stainless steel exterior, aluminum interior
- ★ Efficient: Low energy usage (1.87 KW/24h)
- ★ Convenient: Self-closing doors, LED lighting
- ★ Certified: ETL Electrical, ETL Sanitation, DOE
- ★ Mobility: Locking casters
- ★ Powerful: 1/5 HP compressor
- ★ Sleek: Silver finish, swing doors



Refrigerant	R290
Horsepower (HP)	1/5
Voltage (V)	115V/60hz
KW per 24h	1.87
Wattage	443
Weight (lbs)	180
Shipping Weight (lbs)	200
Door Self closed	Yes
Interior Material	Painted Aluminum
Exterior Material	Stainless Steel
Color	Silver
Door Style	Swing
Door Type	Solid
Number of Doors	2
Compressor Location	Bottom Mounted
Shelf Capacity (lbs)	85
Plug Type	NEMA 5-15P

Introducing our two-door reach-in refrigerator, SKU FGV-RF-2D, meticulously designed to offer outstanding performance and steadfast reliability tailored to meet the demanding requirements of your commercial kitchen. This refrigerator features an expansive interior, with dimensions measuring 50 1/4 inches in width, 24 3/8 inches in depth, and 60 1/2 inches in height, providing an impressive storage capacity of 47.30 cubic feet, thoughtfully designed to accommodate all your essential refrigerated items.

Built with a robust stainless steel exterior and a pristine painted aluminum interior, this unit seamlessly combines durability with a polished and hygienic aesthetic. The substantial 2-inch insulation, utilizing Cyclopentane, ensures superior temperature retention, preserving the freshness of your stored products.

Item	Width (Inch)	Depth (Inch)	Height (Inch)
Exterior	54.1	32	83.5
Interior	50 1/4	24 3/8	60 1/2

Capacity (Cu Ft)	Number of Shelves	Casters	Hotel Pan Size (inch)
47.30	6	Included	12 x 20

- Crafted with a sturdy stainless steel exterior, painted aluminum interior, and a reliable 304 stainless steel floor
- Spacious: Equipped with six epoxy-coated shelves, each capable of supporting up to 85 pounds
- Insulated: Features a substantial 2-inch insulation for optimum temperature retention
- Powerful: Driven by a robust 1/2 HP compressor



Kitchen Pro Restaurant Equipment: info@gokpe.com | www.kitchenproequipment.com | T. 1-800-603-0033

Note: Specifications subject to change without notice.

Equipped with six sturdy epoxy-coated shelves, each with the capacity to support up to 85 pounds, you'll find ample storage space for your ingredients and products. The internal LED lighting ensures outstanding visibility, simplifying the task of locating items within.

Efficiency lies at the heart of this freezer's design, utilizing R290 refrigerant and powered by a commanding 1/2 horsepower compressor operating at 115V/60Hz. This translates to remarkably low energy consumption, a mere 8.80 KW per 24 hours, translating to significant long-term cost savings.

Hinge Location	Amps (A)	Hertz (Hz)	Temperature Range	Caster Size (inch)
Left/Right	3.5	60	33°F to 40°F	4.88

The Frigos brand is synonymous with unwavering quality, and this refrigerator is no exception. Whether you operate within the foodservice industry or a commercial kitchen, you can rely on this unit to maintain your products at their desired refrigerated temperatures, preserving their freshness and quality.

Two Door Reach-In Refrigerator SKU: FGV-FZ-2D

The self-closing doors not only add convenience but also boost energy efficiency by securely locking when necessary. The unit's mobility is effortlessly enabled by 4 7/8 inches casters, with the option to lock two of them in place to ensure stability.



Invest in the future of your business with our FGV-RF-2D two-door reach-in refrigerator. It embodies a powerful, energy-efficient, and reliable addition to any kitchen, meticulously designed to meet your needs for many years to come.

Technical Data:

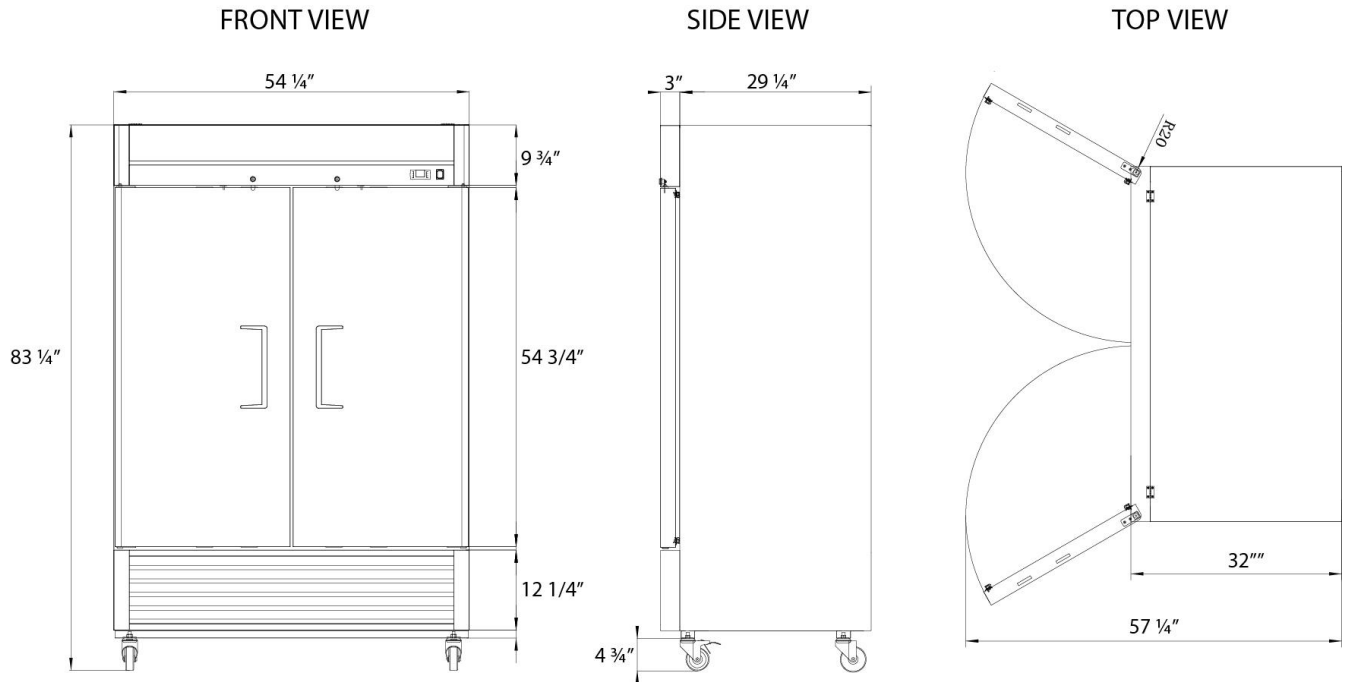

Two Door Reach-In Freezer SKU: FGV-FZ-2D

Our FGV-FZ-2D freezer boasts ETL Electrical, ETL Sanitation, and DOE certifications, ensuring compliance with essential health and safety standards. Its sleek silver finish and swing-style solid doors not only project a professional appearance but also provide effortless access to your frozen inventory.



Warning: This product can expose you to chemicals including lead, which are known to the State of California to cause cancer, birth defects, or other reproductive harm. For more information, go to www.p65warnings.ca.gov.