



## Frigos Value Series 1 Door Refrigerated Pizza Prep Table

SKU: FGV-PZPT-44

- ★ Spacious: 10.9 cu ft capacity
- ★ Durable: Stainless steel exterior, painted aluminum interior
- ★ Efficient: Low energy usage (2.89 kW/24h)
- ★ Convenient: Self-closing door, efficient LED lighting
- ★ Certified: ETL Electrical, ETL Sanitation, DOE
- ★ Mobility: Locking casters
- ★ Powerful: 1/6 HP compressor
- ★ Sleek: Silver finish, swing-style solid door



<b>Refrigerant</b>	R290
<b>Horsepower (HP)</b>	1/6
<b>Voltage (V)</b>	115V/60Hz
<b>KW per 24h</b>	2.89 kW/h/24h
<b>Wattage</b>	327
<b>Shipping Weight (lbs)</b>	286.6
<b>Door Self Closed</b>	Yes
<b>Interior Material</b>	Painted Aluminum
<b>Exterior Material</b>	Stainless Steel
<b>Color</b>	Silver
<b>Door Style</b>	Swing
<b>Door Type</b>	Solid
<b>Number of Doors</b>	1
<b>Compressor Location</b>	Rear Mounted
<b>Shelf Capacity (lbs)</b>	85
<b>Plug Type</b>	NEMA 5-15P

Introducing our one-door commercial pizza prep table, model FGV-PZPT-44, built to deliver exceptional performance and reliability for your commercial kitchen. This pizza prep table offers a spacious interior, with precise measurements of 40 inches in width, 26 inches in depth, and 26 1/2 inches in height, providing ample storage with a capacity of 10.9 cubic feet, designed to accommodate all your refrigerated items.

Made with a strong stainless steel exterior and a clean, easy-to-maintain painted aluminum interior, this unit combines durability with a clean and hygienic look. The thick 2-inch insulation, using Cyclopentane, ensures excellent temperature control, keeping your products fresh.

Item	Width (Inch)	Depth (Inch)	Height (Inch)
<b>Exterior</b>	44	32 1/4	41 3/4
<b>Interior</b>	40	26	26 1/2

Capacity (Cu Ft)	Number of Shelves
10.9	1

- Crafted with a robust stainless steel exterior, a pristine painted aluminum interior, and a dependable 304 stainless steel floor
- Generously Spacious: Equipped with 1 epoxy-coated shelf, with the capacity to support up to 85 pounds
- Exceptionally Insulated: Boasts a substantial 2-inch insulation for optimal temperature retention
- Highly Powerful: Driven by an accurate 1/6 HP compressor for superior performance and reliability

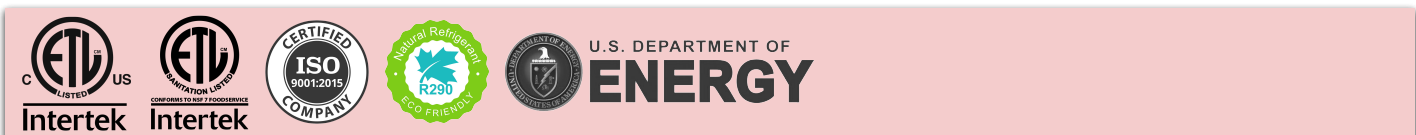

Equipped with a sturdy shelf that can hold up to 85 pounds, you'll have plenty of space for your ingredients and items. The built-in LED lighting ensures you can see everything clearly inside.

This pizza prep table is energy-efficient, using eco-friendly R290 refrigerant and powered by a 1/6 horsepower compressor operating at 115V/60Hz. This means it consumes very little energy, costing only 2.89 kW.h/24h, saving you money in the long run.

Hinge Location	Amps (A)	Hertz (Hz)	Temperature Range
Right	3	60	32°F to 40°F
Phase	Plastic Food Pans	Casters	Caster Size (inch)
1	Included	Included	5.75

The Frigos brand is known for quality, and this pizza prep table lives up to that reputation. Whether you're in the foodservice industry or running a commercial kitchen, you can trust this unit to keep your products at the right temperature, preserving their quality.

## 1 Door Refrigerated Pizza Prep Table | FGV-PZPT-44

The self-closing door adds convenience and saves energy by ensuring it's always properly sealed. It's easy to move around with four 5 3/4-inch casters that provide stability.



Invest in the future of your business with our FGV-PZPT-44 one-door pizza prep table, perfect for your pizza prep needs. It's a powerful, energy-efficient, and reliable addition to any kitchen, designed to meet your needs for years to come. And don't forget to explore our selection of pizza prep tables and other equipment to streamline your pizza-making process.

## Technical Data:

FRONT VIEW

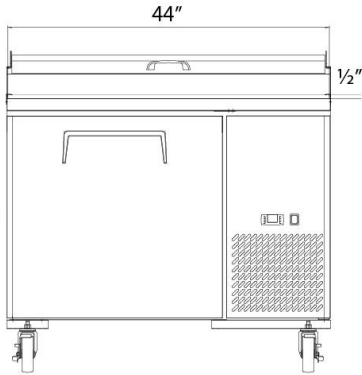

TOP VIEW

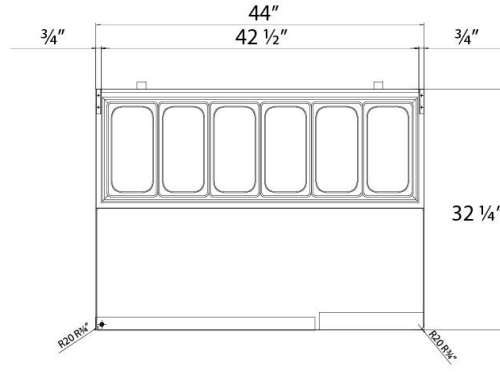

TOP VIEW

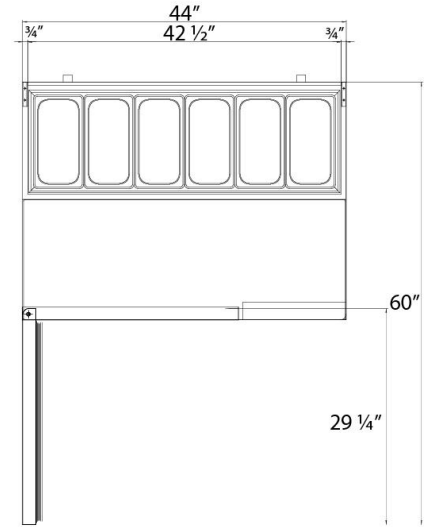

### 1 Door Refrigerated Pizza Prep Table | FGV-PZPT-44

Our FGV-PZPT-44 pizza prep table is certified by ETL Electrical, ETL Sanitation, and DOE, meeting essential health and safety standards. Its stylish silver finish and swing-style solid door not only look professional but also offer easy access to your refrigerated items.

SIDE VIEW

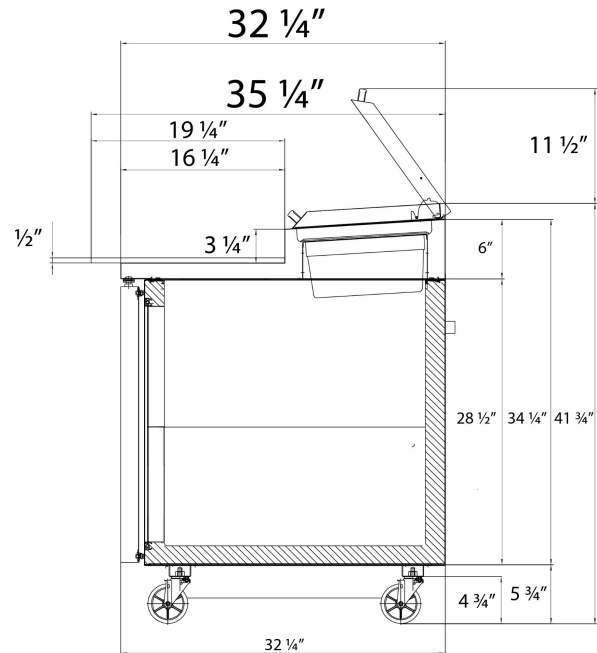

**Warning:** This product can expose you to chemicals including lead, which are known to the State of California to cause cancer, birth defects, or other reproductive harm. For more information, go to [www.p65warnings.ca.gov](http://www.p65warnings.ca.gov).