



Frigos Value Series Two Door Reach-In Freezer

SKU: FGV-FZ-2D

- ★ Spacious: 47.30 cu ft capacity
- ★ Durable: Stainless steel exterior, aluminum interior
- ★ Efficient: Low energy usage (8.80 KW/24h)
- ★ Convenient: Self-closing doors, LED lighting
- ★ Certified: ETL Electrical, ETL Sanitation, DOE
- ★ Mobility: Locking casters
- ★ Powerful: Forced air freezing system with auto defrost
- ★ Sleek: Silver finish, swing doors



Refrigerant	R290
Horsepower (HP)	1/2
Voltage (V)	115V/60hz
KW per 24h	8.80 kW.h/24h
Wattage	738
Weight (lbs)	183
Shipping Weight (lbs)	204
Door Self closed	Yes
Interior Material	Painted Aluminum
Exterior Material	Stainless Steel
Color	Silver
Door Style	Swing
Door Type	Solid
Number of Doors	2
Compressor Location	Bottom Mounted
Shelf Capacity (lbs)	85
Plug Type	NEMA 5-15P

Introducing our two-door reach-in freezer, SKU FGV-FZ-2D, meticulously designed to deliver exceptional performance and unwavering reliability to meet the demands of your commercial kitchen. This freezer showcases a capacious interior, with dimensions spanning 50 1/4 inches in width, 24 3/8 inches in depth, and 60 1/2 inches in height, providing an impressive storage capacity of 47.30 cubic feet, tailored to accommodate all your essential frozen goods.

Crafted with a robust stainless steel exterior and a pristine painted aluminum interior, this unit harmoniously merges durability with a polished and hygienic aesthetic. The substantial 2-inch insulation, featuring Cyclopentane, guarantees optimum temperature retention, preserving your frozen products in impeccable condition.

Item	Width (Inch)	Depth (Inch)	Height (Inch)
Exterior	54.1	32	83.5
Interior	50 1/4	24 3/8	60 1/2

Capacity (Cu Ft)	Number of Shelves	Casters	Hotel Pan Size (inch)
47.30	6	Included	12 x 20

- Crafted with a sturdy stainless steel exterior, painted aluminum interior, and a reliable 304 stainless steel floor
- Spacious: Equipped with six epoxy-coated shelves, each capable of supporting up to 85 pounds
- Insulated: Features a substantial 2-inch insulation for optimum temperature retention
- Powerful: Driven by a robust 1/2 HP compressor



Kitchen Pro Restaurant Equipment: info@gokpe.com | www.kitchenproequipment.com | T. 1-800-603-0033

Note: Specifications subject to change without notice.

Equipped with six sturdy epoxy-coated shelves, each with the capacity to support up to 85 pounds, you'll find ample storage space for your ingredients and products. The internal LED lighting ensures outstanding visibility, simplifying the task of locating items within.

Efficiency lies at the heart of this freezer's design, utilizing R290 refrigerant and powered by a commanding 1/2 horsepower compressor operating at 115V/60Hz. This translates to remarkably low energy consumption, a mere 8.80 KW per 24 hours, translating to significant long-term cost savings.

Hinge Location	Amps (A)	Hertz (Hz)	Temperature Range	Caster Size (inch)
Left/Right	7.1A	60	-8°F to -1°F	4.88

The Frigos brand is synonymous with uncompromising quality, and this freezer upholds that reputation. Whether you operate in the foodservice industry or a commercial kitchen, you can entrust this unit to maintain your products at their desired frozen temperatures, safeguarding their freshness and quality.

Two Door Reach-In Freezer SKU: FGV-FZ-2D

The self-closing doors not only add convenience but also boost energy efficiency by securely locking when necessary. The unit's mobility is effortlessly enabled by 4 7/8 inches casters, with the option to lock two of them in place to ensure stability.



Invest in the future of your business with our FGV-FZ-2D two-door reach-in refrigerator. It's a powerful, energy-efficient, and dependable addition to any kitchen, designed to meet your needs for years to come.

Technical Data:

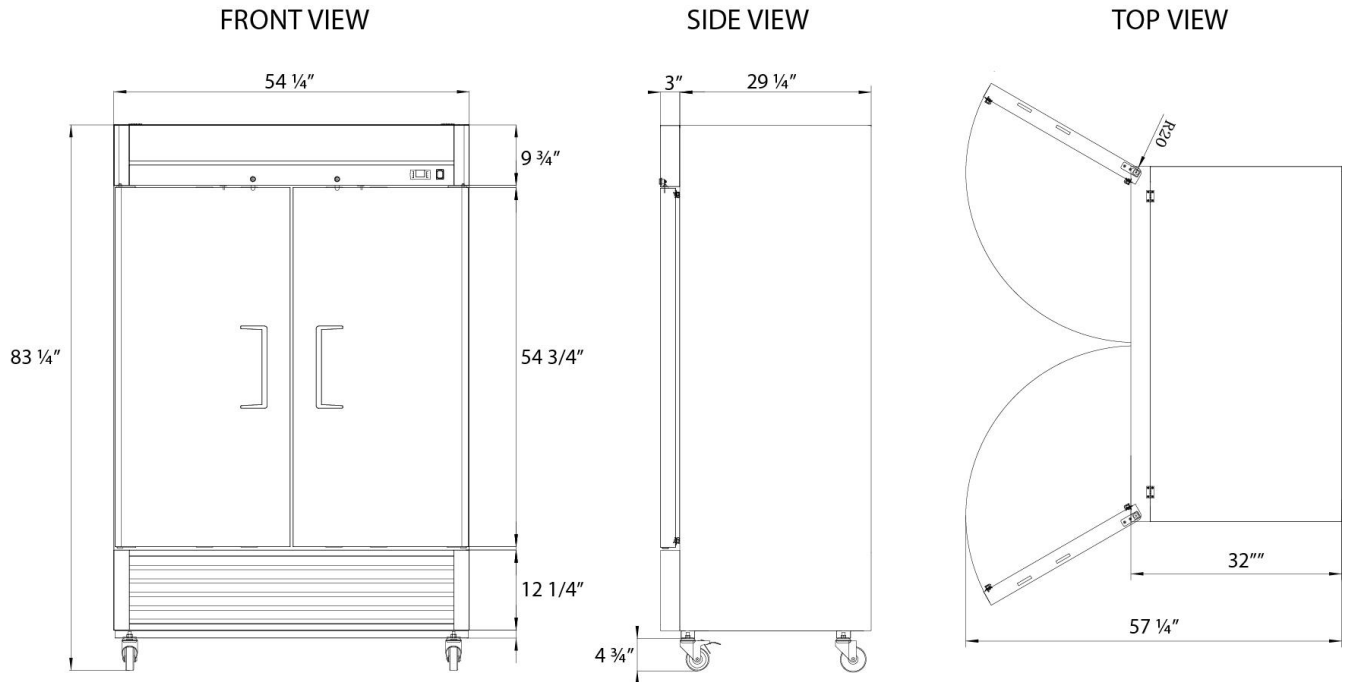

Two Door Reach-In Freezer SKU: FGV-FZ-2D

With ETL Electrical, ETL Sanitation, and DOE certifications, this freezer meets all necessary health and safety standards. Its sleek silver finish and swing-style solid doors not only offer a professional appearance but also provide easy access to your stored items.



Warning: This product can expose you to chemicals including lead, which are known to the State of California to cause cancer, birth defects, or other reproductive harm. For more information, go to www.p65warnings.ca.gov.