



## Frigos Value Series One Door Reach-In Freezer

SKU: FGV-FZ-1D

- ★ Spacious: 21.50 cu ft capacity
- ★ Durable: Stainless steel exterior, painted aluminum interior
- ★ Efficient: Low energy usage (3.94 KW/24h)
- ★ Convenient: Self-closing door, efficient LED lighting
- ★ Certified: ETL Electrical, ETL Sanitation, DOE
- ★ Mobility: Locking casters
- ★ Powerful: 1/4 HP compressor
- ★ Sleek: Silver finish, swing-style solid door



Refrigerant	R290
Horsepower (HP)	1/4
Voltage (V)	115V/60Hz
KW per 24h	3.94 kW.h/24h
Wattage	479
Weight (lbs)	117
Shipping Weight (lbs)	130
Door Self closed	Yes
Interior Material	Painted Aluminum
Exterior Material	Stainless Steel
Color	Silver
Door Style	Swing
Door Type	Solid
Number of Doors	1
Compressor Location	Bottom Mounted
Shelf Capacity (lbs)	85
Plug Type	NEMA 5-15P

Introducing our one-door reach-in freezer, FGV-FZ-1D, meticulously engineered to provide exceptional performance and unwavering reliability, perfectly suited to the rigorous demands of your commercial kitchen. This freezer showcases a capacious interior, with dimensions spanning 23 inches in width, 24 3/8 inches in depth, and 60 1/2 inches in height, offering an ample storage capacity of 21.50 cubic feet, thoughtfully designed to accommodate all your frozen essentials.

Constructed with a robust stainless steel exterior and a pristine painted aluminum interior, this unit seamlessly merges durability with a polished and hygienic aesthetic. The substantial 2-inch insulation, featuring Cyclopentane, ensures superior temperature retention, preserving your frozen products in impeccable condition.

Item	Width (Inch)	Depth (Inch)	Height (Inch)
Exterior	27	32	83.5
Interior	23	24 3/8	60 1/2

Capacity (Cu Ft)	Number of Shelves	Casters	Hotel Pan Size (inch)
21.5	3	Included	12 x 20

- Crafted with a sturdy stainless steel exterior, painted aluminum interior, and a reliable 304 stainless steel floor
- Spacious: Equipped with three epoxy-coated shelves, each capable of supporting up to 85 pounds
- Insulated: Features a substantial 2-inch insulation for optimum temperature retention
- Powerful: Driven by a robust 1/4 HP compressor



Kitchen Pro Restaurant Equipment: [info@gokpe.com](mailto:info@gokpe.com) | [www.kitchenproequipment.com](http://www.kitchenproequipment.com) | T. 1-800-603-0033

Note: Specifications subject to change without notice.

Equipped with three sturdy epoxy-coated shelves, each with the capacity to support up to 85 pounds, you'll discover generous storage space for your ingredients and products. The integrated LED lighting guarantees exceptional visibility, simplifying the task of locating items within.

Efficiency is at the heart of this freezer's design, utilizing R290 refrigerant and powered by a capable 1/4 horsepower compressor operating at 115V/60Hz. This translates to remarkably low energy consumption, a mere 3.94 KW per 24 hours, leading to significant long-term cost savings.

Hinge Location	Amps (A)	Hertz (Hz)	Temperature Range	Caster Size (inch)
Right	3.5	60	-8°F to -1°F	4.88

The Frigos brand is synonymous with uncompromising quality, and this freezer upholds that reputation. Whether you operate within the foodservice industry or a commercial kitchen, you can entrust this unit to maintain your products at their desired frozen temperatures, safeguarding their freshness and quality.

### One Door Reach-In Freezer SKU: FGV-FZ-1D

The self-closing doors not only add convenience but also boost energy efficiency by securely locking when necessary. The unit's mobility is effortlessly enabled by 4 7/8 inches casters, with the option to lock two of them in place to ensure stability.



Invest in the future of your business with our FGV-FZ-1D one-door reach-in freezer. It represents a potent, energy-efficient, and dependable addition to any kitchen, meticulously designed to meet your needs for many years to come.

## Technical Data:

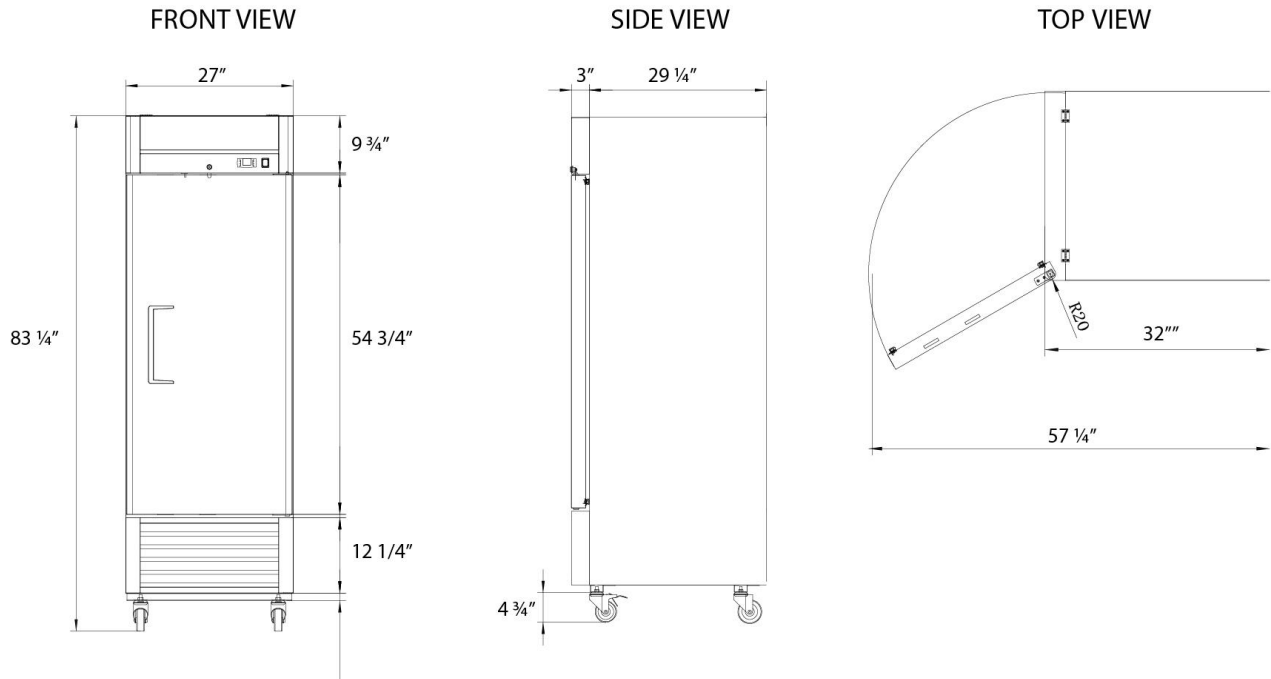

### One Door Reach-In Freezer SKU: FGV-FZ-1D

With ETL Electrical, ETL Sanitation, and DOE certifications, this freezer meets all necessary health and safety standards. Its sleek silver finish and swing-style solid doors not only offer a professional appearance but also provide easy access to your stored items.



**Warning:** This product can expose you to chemicals including lead, which are known to the State of California to cause cancer, birth defects, or other reproductive harm. For more information, go to [www.p65warnings.ca.gov](http://www.p65warnings.ca.gov).