

FRIGOS



Frigos Premium Double Door
Undercounter Freezer
SKU: FGP-UCFZ-60

- ★ 18 cu. ft. interior space
- ★ Equipped with 2 shelves and reliable 1/3 HP compressor
- ★ Stainless steel exterior and interior
- ★ Durable door with rounded corners and recessed handle
- ★ 6" casters for easy mobility
- ★ Digital controller provides temperature readouts
- ★ Temperature holding range: -7°F to 3°F
- ★ Eco-friendly R290 refrigerant, 4.9 KW/24hr consumption



Amps	6.5
Capacity (Cu Ft)	18
Caster Size (Inch)	6
Color	Silver
Compressor Location	Back Mounted
Door Style	Swing
Door Type	Solid
Horsepower (HP)	1/3
KW per 24h	4.9
Number of Doors	2
Number of Shelves	2
Plug Type	Nema 5-15P
Refrigerant	R-290
Shipping Weight (lbs)	277
Temperature Range	-7° F - 3° F
Voltage	115/60/1
Weight (lbs)	264

Presenting the Frigos Premium FGP-UCFZ-60, a high-capacity Double Door Undercounter Freezer with an 18 cubic feet capacity, meticulously designed to meet the demands of your commercial kitchen. This freezer not only provides an abundance of storage space but also ensures that your frozen goods are kept in optimal condition.

The FGP-UCFZ-60 boasts a back-mounted compressor, two solid swinging doors, and two shelves, facilitating easy access and efficient organization of your frozen items. With an impressive temperature range of -7° F to 3° F, it guarantees that your products remain perfectly frozen. This freezer is not only powerful but also energy-efficient, equipped with a 1/3 HP compressor and R-290 refrigerant, which results in a power consumption of 4.9 KW per 24 hours, effectively reducing operational costs.

The sleek silver exterior, 6-inch caster wheels for mobility, and stainless steel interior and exterior give this undercounter freezer a stylish and durable appeal. Whether you run a bustling restaurant, a catering business, or any other food establishment, the Frigos Premium FGP-UCFZ-60 is the perfect choice for preserving the quality and accessibility of your frozen goods, ensuring that your kitchen operates at its best.

Item	Width (Inch)	Depth (Inch)	Height (Inch)	Material
Exterior	60.2	30	37.25	Stainless steel
Interior	56.7	23.6	26.7	Stainless steel



Kitchen Pro Restaurant Equipment: info@gokpe.com | www.kitchenproequipment.com | T. 1(800)603-0033

Note: Specifications subject to change without notice.

Plan View

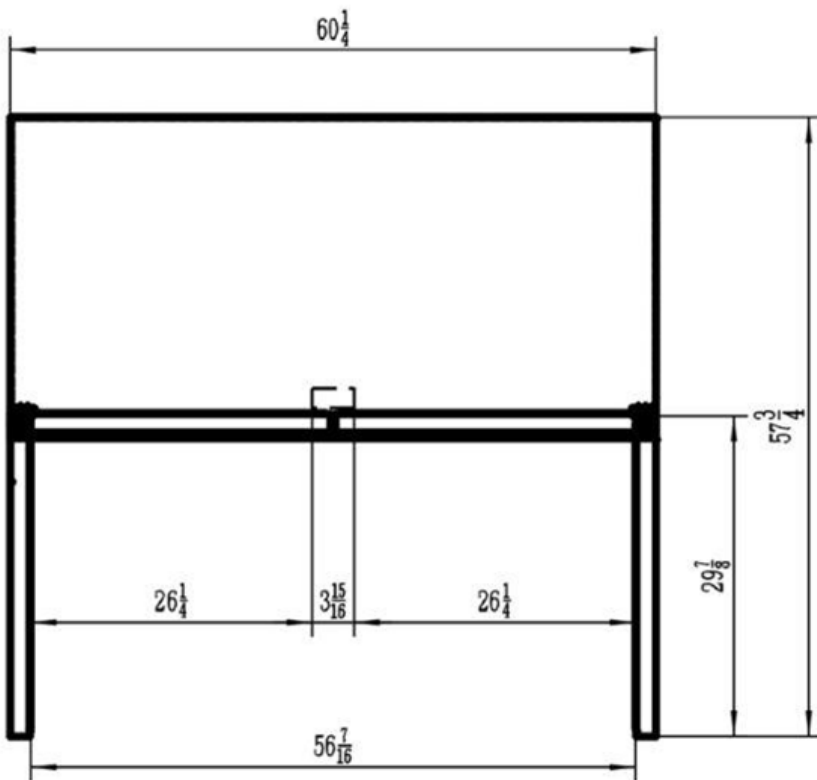
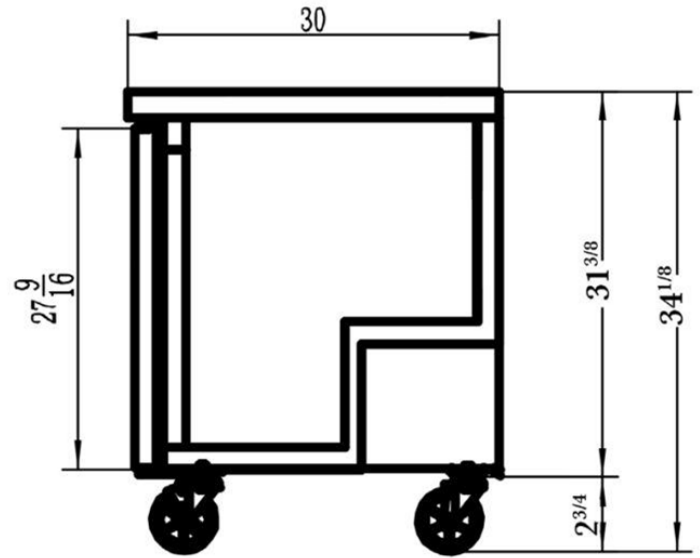
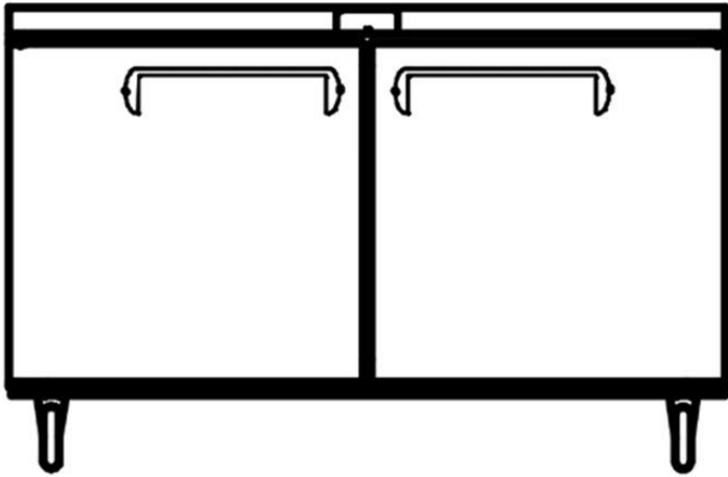

Frigos Premium FGP-UCFZ-60 stands as a reliable and efficient solution for businesses seeking top-notch frozen storage. Elevate your commercial kitchen's performance with this high-capacity, energy-efficient double door undercounter freezer, combining functionality with a sleek design to meet the demanding needs of your culinary operations.

Warning: This product can expose you to chemicals including lead, which are known to the State of California to cause cancer, birth defects, or other reproductive harm. For more information, go to www.p65warnings.ca.gov.