

FRIGOS



Frigos Premium 3-Door Refrigerated Sandwich Prep Table SKU: FGP-SLM-3D

- ★ 24.5 cu. ft. interior space
- ★ Equipped with 3 shelves and 1/5 HP compressor
- ★ Stainless steel exterior and interior
- ★ Durable door with recessed handle
- ★ 6" casters for easy mobility
- ★ Digital controller provides temperature readouts
- ★ Temperature holding range: 33°F to 41°F
- ★ Eco-friendly R290 refrigerant, 4.1 KW/24hr consumption



Amps	5.7
Capacity (Cu Ft)	24.5
Caster Size (Inch)	6
Color	Silver
Compressor Location	Back Mounted
Door Style	Swing
Door Type	Solid
Horsepower (HP)	1/5
KW per 24h	4.1
Number of Doors	3
Number of Shelves	3
Plug Type	Nema 5-15P
Refrigerant	R-290
Shipping Weight (lbs)	374
Temperature Range	33°F to 41°F
Voltage	115/60/1
Weight (lbs)	331

Introducing the Frigos Premium FGP-SLM-3D, a spacious 3-Door Refrigerated Sandwich Prep Table with a generous 24.5 cubic feet capacity, meticulously crafted to elevate your commercial kitchen efficiency. This prep table combines ample storage space with a dedicated work surface, making it an indispensable asset for sandwich and salad preparation.

Designed for convenience, the FGP-SLM-3D features a back-mounted compressor, three swinging solid doors, and three shelves for easy access and organization of your ingredients. With a temperature range of 33°F to 41°F, it ensures your ingredients remain fresh and at the ideal temperature. Powered by a 1/5 HP compressor and eco-friendly R290 refrigerant, this prep table consumes just 4.1 KW per 24 hours, reducing energy costs.

Its sleek silver exterior, sturdy 6-inch caster wheels, and stainless steel interior and exterior not only add a touch of elegance to your kitchen but also ensure durability and easy mobility. Whether you're running a bustling restaurant, a deli, or a catering business, the Frigos Premium FGP-SLM-3D is your trusted partner for efficient ingredient storage and sandwich/salad preparation, ensuring your kitchen operates at peak performance.

Item	Width (Inch)	Depth (Inch)	Height (Inch)	Material
Exterior	72.7	34	47.1	Stainless steel
Interior	69.1	23.6	26.4	Stainless steel



Kitchen Pro Restaurant Equipment: info@gokpe.com | www.kitchenproequipment.com | T. 1(800)603-0033

Note: Specifications subject to change without notice.

Plan View

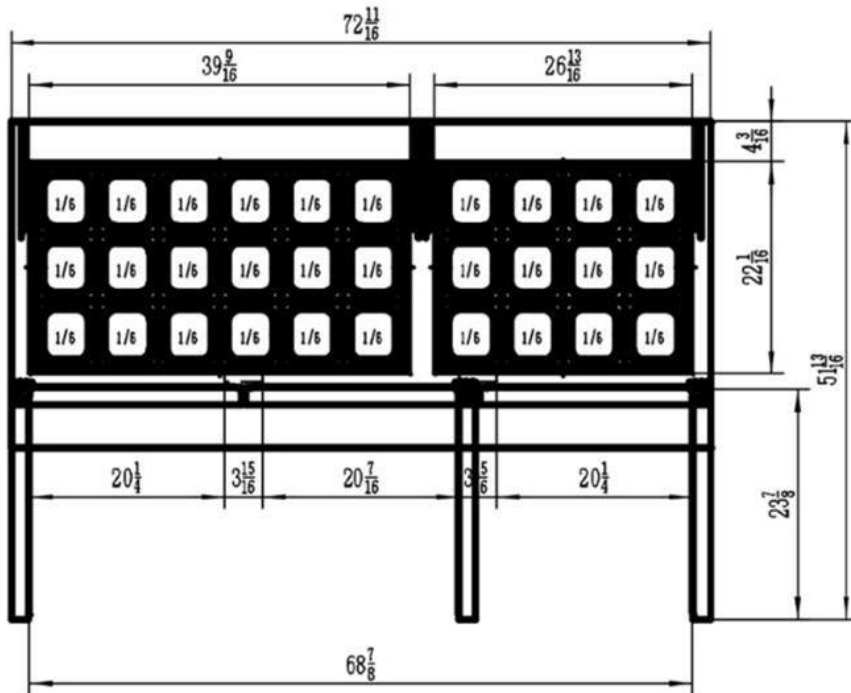
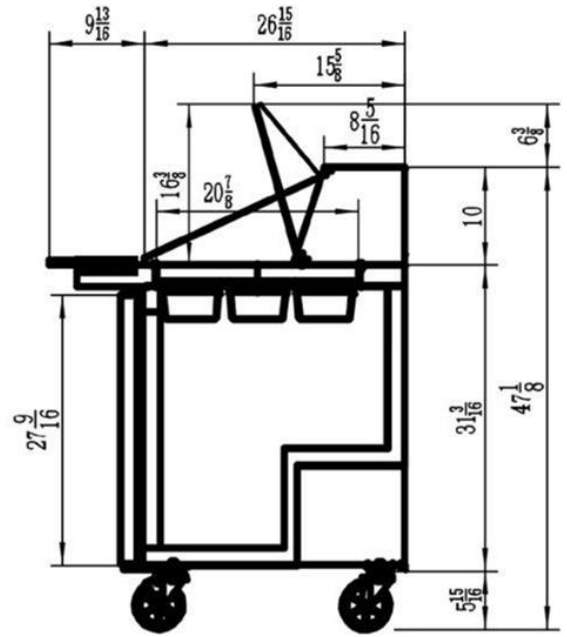
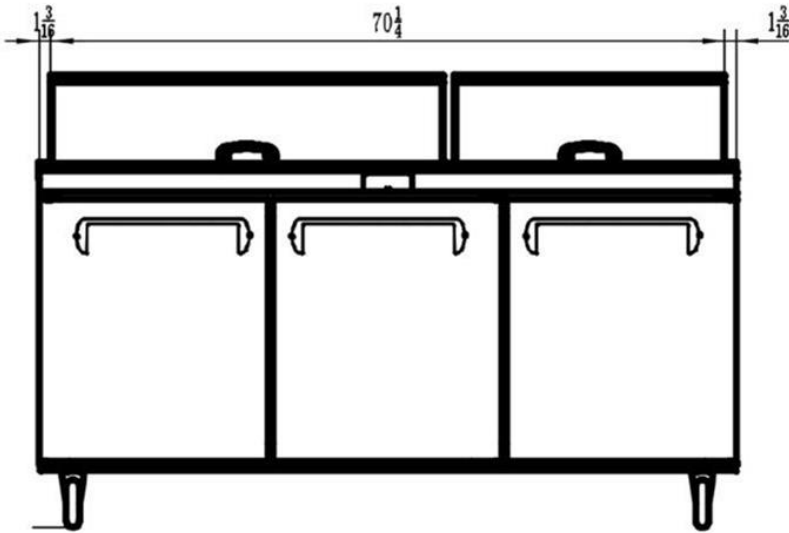

Upgrade your commercial kitchen efficiency with the Frigos Premium FGP-SLM-3D—a 3-Door Refrigerated Sandwich Prep Table boasting a generous 24.5 cubic feet capacity. Choose Frigos Premium for reliable and stylish solutions in your kitchen.

Warning: This product can expose you to chemicals including lead, which are known to the State of California to cause cancer, birth defects, or other reproductive harm. For more information, go to www.p65warnings.ca.gov.