

FRIGOS



Frigos Premium Mega Top Bain
Marie Sandwich Prep Refrigerator
SKU: FGP-SLM-2D

- ★ 12.0 cu. ft. interior space
- ★ Equipped with 2 shelves and 1/7+ HP compressor
- ★ Stainless steel exterior and interior
- ★ Durable door with recessed handle
- ★ 6" casters for easy mobility
- ★ Digital controller provides temperature readouts
- ★ Temperature holding range: 33°F to 41°F
- ★ Eco-friendly R290 refrigerant, 3.6 KW/24hr consumption



Amps	5.1
Capacity (Cu Ft)	12
Caster Size (Inch)	6
Color	Silver
Compressor Location	Back Mounted
Door Style	Swing
Door Type	Solid
Horsepower (HP)	1/7+
KW per 24h	3.6
Number of Doors	2
Number of Shelves	2
Plug Type	Nema 5-15P
Refrigerant	R-290
Shipping Weight (lbs)	280
Temperature Range	33°F to 41°F
Voltage	115/60/1
Weight (lbs)	243

Introducing the Frigos Premium FGP-SLM-2D, a versatile 48" Mega Top Bain Marie Sandwich Prep Refrigerator equipped to streamline your kitchen's sandwich and salad preparation. With an 18-pan capacity, this prep refrigerator ensures you have ample storage and workspace to keep your ingredients fresh and ready to serve.

Designed for convenience, the FGP-SLM-2D features a back-mounted compressor, two solid swing doors, and two shelves, providing quick access and efficient organization of your ingredients. With a temperature range of 33°F to 41°F, it maintains your ingredients at the ideal temperature for optimal freshness. This prep refrigerator is equipped with a robust 1/7+ HP compressor and uses eco-friendly R290 refrigerant, resulting in low power consumption at just 3.6 KW per 24 hours.

Its sleek silver exterior, robust 6-inch caster wheels for mobility, and stainless steel interior and exterior add style and durability to your kitchen setup. Whether you're operating a bustling restaurant, deli, or a catering business, the Frigos Premium FGP-SLM-2D is your reliable partner for efficient ingredient storage and sandwich/salad preparation, ensuring your kitchen operates at peak performance.

Item	Width (Inch)	Depth (Inch)	Height (Inch)	Material
Exterior	48.2	34	47.1	Stainless steel
Interior	44.7	23.6	26.4	Stainless steel



Kitchen Pro Restaurant Equipment: info@gokpe.com | www.kitchenproequipment.com | T. 1(800)603-0033

Note: Specifications subject to change without notice.

Plan View

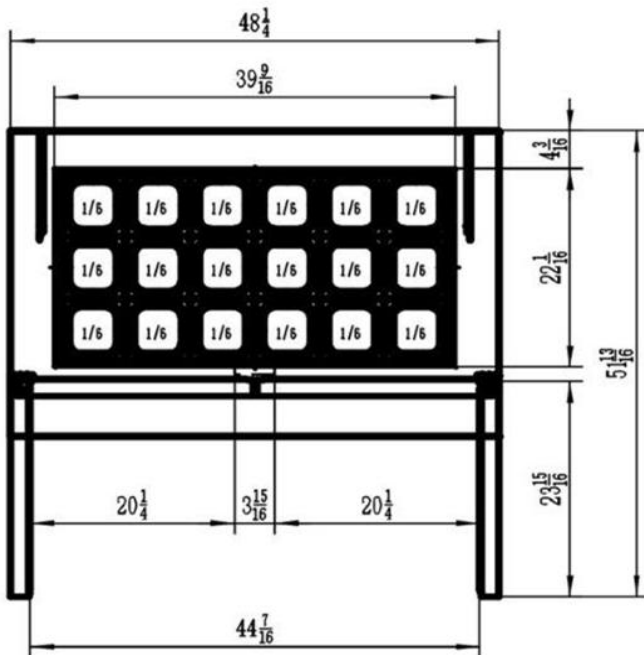
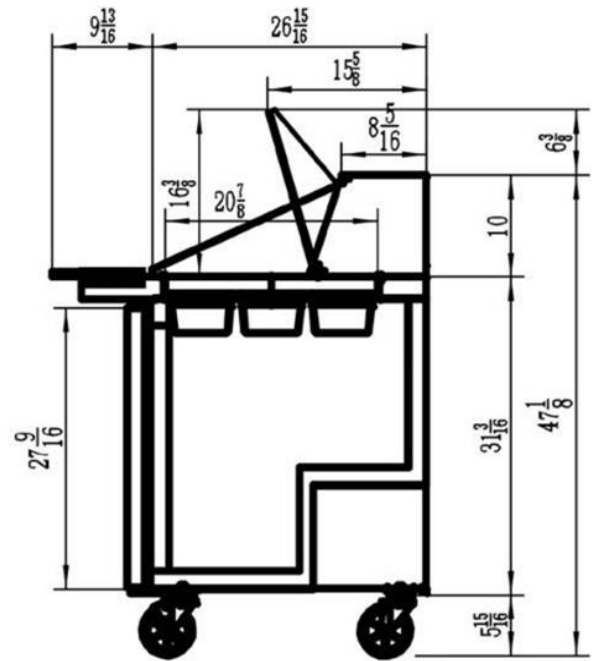
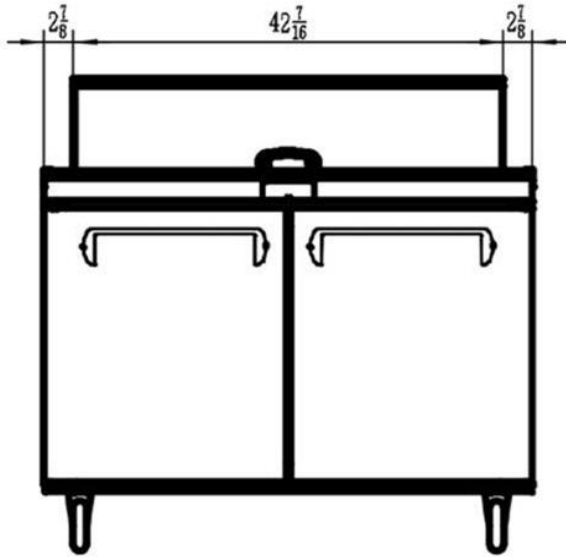

Upgrade your kitchen efficiency with the Frigos Premium 48" Mega Top Bain Marie Sandwich Prep Refrigerator featuring an 18-pan capacity. With solid swing doors, optimal temperature control, and a sleek design, this prep refrigerator ensures convenient ingredient access and freshness, making it the ideal choice for peak performance in restaurants, delis, and catering businesses.

Warning: This product can expose you to chemicals including lead, which are known to the State of California to cause cancer, birth defects, or other reproductive harm. For more information, go to www.p65warnings.ca.gov.