

FRIGOS



Frigos Premium 3-Door Refrigerated Sandwich Prep Table SKU: FGP-SL-3D

- ★ 24.5 cu. ft. interior space
- ★ Equipped with 3 shelves and 1/2 HP compressor
- ★ Stainless steel exterior and interior
- ★ Durable door with recessed handle
- ★ 6" casters for easy mobility
- ★ Digital controller provides temperature readouts
- ★ Temperature holding range: 33°F to 41°F
- ★ Eco-friendly R290 refrigerant, 4.1 KW/24hr consumption



Amps	5.7
Capacity (Cu Ft)	24.5
Caster Size (Inch)	6
Color	Silver
Compressor Location	Back Mounted
Door Style	Swing
Door Type	Solid
Horsepower (HP)	1/2
KW per 24h	4.1
Number of Doors	3
Number of Shelves	3
Plug Type	Nema 5-15P
Refrigerant	R-290
Shipping Weight (lbs)	366
Temperature Range	33°F to 41°F
Voltage	115/60/1
Weight (lbs)	375

Introducing the Frigos Premium FGP-SL-3D, a remarkable 72.7" 3-Door Refrigerated Sandwich Prep Table, meticulously designed to meet the high demands of commercial kitchens. With a spacious 24.5 cubic feet capacity, this prep table combines extensive ingredient storage with an efficient work surface, making it an invaluable asset for sandwich and salad preparation.

The FGP-SL-3D features a back-mounted compressor, three solid swing doors, and three shelves for easy access and organization of your ingredients. With a temperature range of 33°F to 41°F, it ensures your ingredients remain at the ideal temperature for freshness. Equipped with a robust 1/2 HP compressor and eco-friendly R290 refrigerant, this prep table is designed for energy efficiency, consuming 4.1 KW per 24 hours, which translates into cost savings for your business.

Its sleek silver exterior, sturdy 6-inch caster wheels for easy mobility, and durable stainless steel interior and exterior not only add a touch of sophistication to your kitchen but also guarantee longevity and ease of use. Whether you're operating a bustling restaurant, a deli, or a catering business, the Frigos Premium FGP-SL-3D is your reliable partner for efficient ingredient storage and sandwich/salad preparation, ensuring your kitchen operates at peak performance.

Item	Width (Inch)	Depth (Inch)	Height (Inch)	Material
Exterior	72.7	30	44.3	Stainless steel
Interior	56.7	23.6	26.7	Stainless steel



Kitchen Pro Restaurant Equipment: info@gokpe.com | www.kitchenproequipment.com | T. 1(800)603-0033

Note: Specifications subject to change without notice.

Plan View

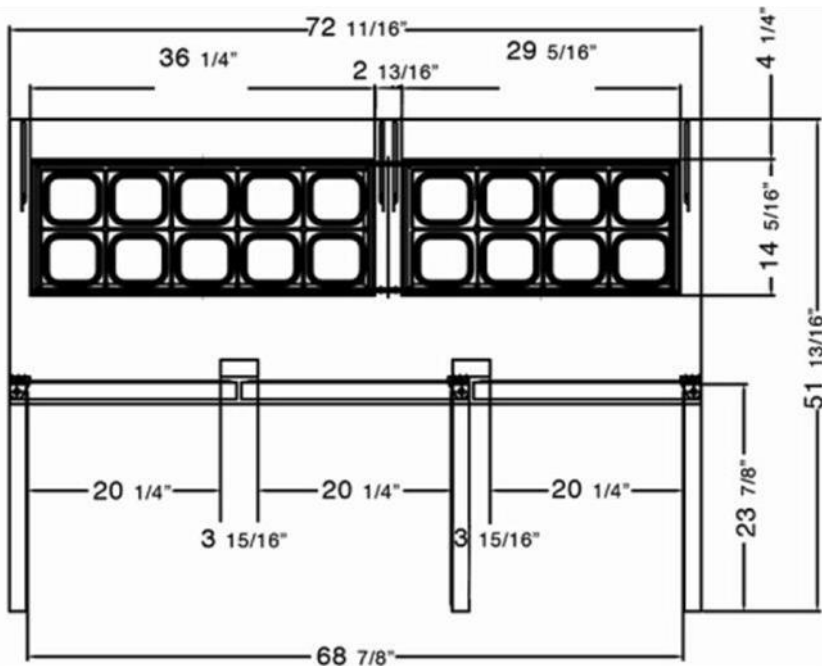
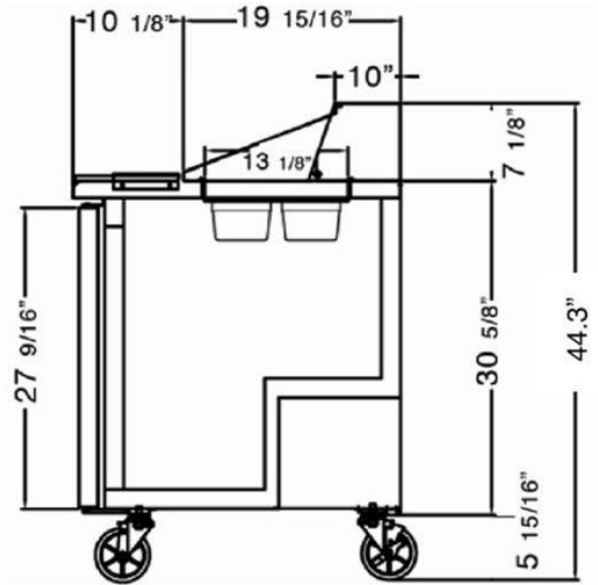
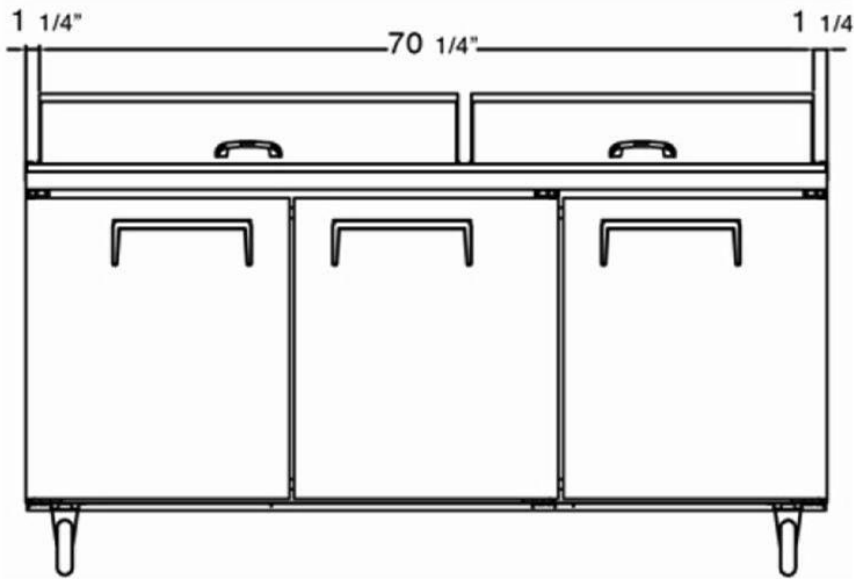

Elevate your commercial kitchen with the Frigos Premium FGP-SL-3D—a 72.7" 3-Door Refrigerated Sandwich Prep Table offering a spacious 24.5 cubic feet capacity. With solid swing doors, optimal temperature control, and a stylish design, this prep table ensures efficient ingredient access and freshness, making it the ideal choice for high-demand establishments focused on peak performance.

Warning: This product can expose you to chemicals including lead, which are known to the State of California to cause cancer, birth defects, or other reproductive harm. For more information, go to www.p65warnings.ca.gov.