

FRIGOS



Frigos Premium 2-Door Refrigerated Sandwich Prep Table SKU: FGP-SL-2D/60

- ★ 18.2 cu. ft. interior space
- ★ Equipped with 2 shelves and 1/2 HP compressor
- ★ Stainless steel exterior and interior
- ★ Durable door with recessed handle
- ★ 6" casters for easy mobility
- ★ Digital controller provides temperature readouts
- ★ Temperature holding range: 33°F to 41°F
- ★ Eco-friendly R290 refrigerant, 3.6 KW/24hr consumption



Amps	5.1
Capacity (Cu Ft)	18.2
Caster Size (Inch)	6
Color	Silver
Compressor Location	Back Mounted
Door Style	Swing
Door Type	Solid
Horsepower (HP)	1/2
KW per 24h	3.6
Number of Doors	2
Number of Shelves	2
Plug Type	Nema 5-15P
Refrigerant	R-290
Shipping Weight (lbs)	307
Temperature Range	33°F to 41°F
Voltage	115/60/1
Weight (lbs)	294

Introducing the Frigos Premium FGP-SL-2D/60, a 60.2" 2-Door Refrigerated Sandwich Prep Table that offers a spacious 18.2 cubic feet capacity, designed to elevate your kitchen's sandwich and salad preparation to a new level of efficiency. This prep table combines generous storage space with a dedicated work surface, ensuring your ingredients remain fresh and ready for quick and efficient meal preparation.

The FGP-SL-2D/60 features a back-mounted compressor, two solid swing doors, and two shelves, providing convenient access and organization of your ingredients. With a temperature range of 33°F to 41°F, it keeps your ingredients at the ideal temperature for optimal freshness. Powered by a robust 1/2 HP compressor and using eco-friendly R290 refrigerant, this prep table is designed to be energy-efficient, consuming only 3.6 KW per 24 hours, resulting in cost savings for your business.

With its sleek silver exterior, robust 6-inch caster wheels for easy mobility, and a durable stainless steel interior and exterior, this prep table not only adds a touch of style to your kitchen but also ensures longevity and ease of use. Whether you run a bustling restaurant, deli, or catering business, the Frigos Premium FGP-SL-2D/60 is your trusted choice for efficient ingredient storage and sandwich/salad preparation, ensuring your kitchen operates at peak performance.

Item	Width (Inch)	Depth (Inch)	Height (Inch)	Material
Exterior	60.2	30	44.3	Stainless steel
Interior	57.7	23.6	26.7	Stainless steel



Kitchen Pro Restaurant Equipment: info@gokpe.com | www.kitchenproequipment.com | T. 1(800)603-0033

Note: Specifications subject to change without notice.

Plan View

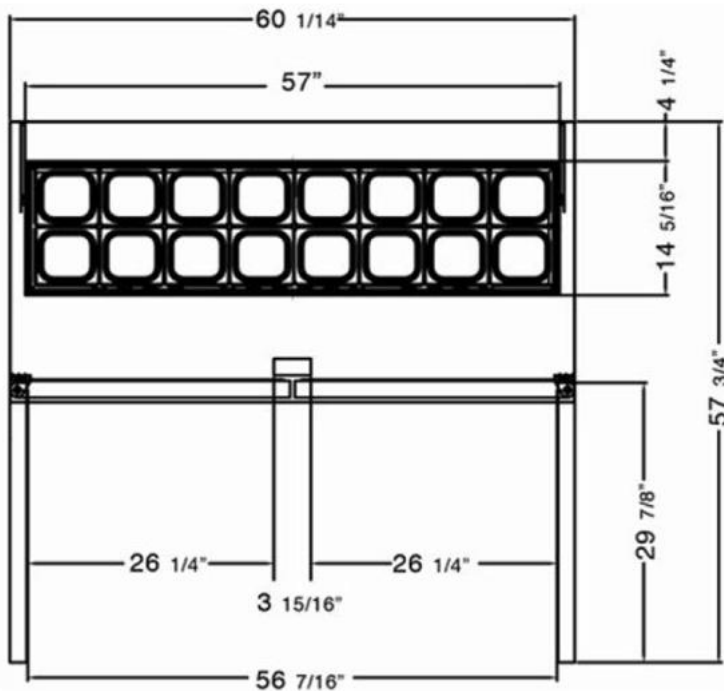
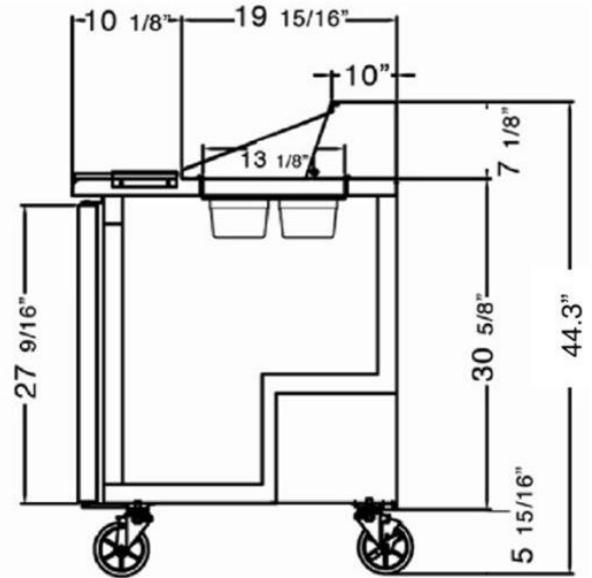
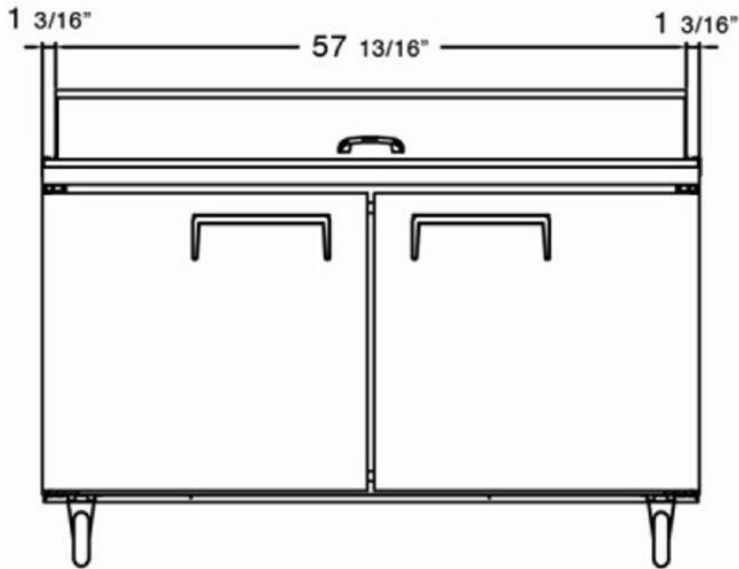

Upgrade your kitchen efficiency with the Frigos Premium FGP-SL-2D/60—a 60.2" 2-Door Refrigerated Sandwich Prep Table. This sleek and spacious prep table, with a generous 18.2 cubic feet capacity and optimal temperature control, ensures easy access to fresh ingredients for peak performance in restaurants, delis, and catering businesses.

Warning: This product can expose you to chemicals including lead, which are known to the State of California to cause cancer, birth defects, or other reproductive harm. For more information, go to www.p65warnings.ca.gov.