

FRIGOS



Frigos Premium 2-Door Refrigerated Sandwich Prep Table SKU: FGP-SL-2D

- ★ 12 cu. ft. interior space
- ★ Equipped with 2 shelves and 1/3 HP compressor
- ★ Stainless steel exterior and interior
- ★ Durable door with recessed handle
- ★ 6" casters for easy mobility
- ★ Digital controller provides temperature readouts
- ★ Temperature holding range: 33°F to 41°F
- ★ Eco-friendly R290 refrigerant, 3.6 KW/24hr consumption



Amps	5.1
Capacity (Cu Ft)	12
Caster Size (Inch)	6
Color	Silver
Compressor Location	Back Mounted
Door Style	Swing
Door Type	Solid
Horsepower (HP)	1/3
KW per 24h	3.6
Number of Doors	2
Number of Shelves	2
Plug Type	Nema 5-15P
Refrigerant	R-290
Shipping Weight (lbs)	270
Temperature Range	33°F to 41°F
Voltage	115/60/1
Weight (lbs)	270

Introducing the Frigos Premium FGP-SL-2D, a 48.2" 2-Door Refrigerated Sandwich Prep Table that offers a spacious 12 cubic feet capacity, designed to streamline your sandwich and salad preparation in the kitchen. This prep table is equipped to keep your ingredients fresh and readily accessible, making meal preparation a breeze.

The FGP-SL-2D features a back-mounted compressor, two solid swing doors, and two shelves for easy access and organization of your ingredients. With a temperature range of 33°F to 41°F, it ensures that your ingredients stay at the perfect temperature for freshness. Powered by a 1/3 HP compressor and utilizing eco-friendly R-290 refrigerant, this prep table consumes just 3.6 KW per 24 hours, ensuring energy efficiency and cost savings.

This prep table combines a sleek silver exterior, robust 6-inch caster wheels for mobility, and a durable stainless steel interior and exterior. Whether you're running a bustling restaurant, deli, or catering business, the Frigos Premium FGP-SL-2D is your trusted choice for efficient ingredient storage and sandwich/salad preparation, ensuring your kitchen operates at peak performance.

Item	Width (Inch)	Depth (Inch)	Height (Inch)	Material
Exterior	48.2	30	44.3	Stainless steel
Interior	44.7	23.6	26.7	Stainless steel



Kitchen Pro Restaurant Equipment: info@gokpe.com | www.kitchenproequipment.com | T. 1(800)603-0033

Note: Specifications subject to change without notice.

Plan View

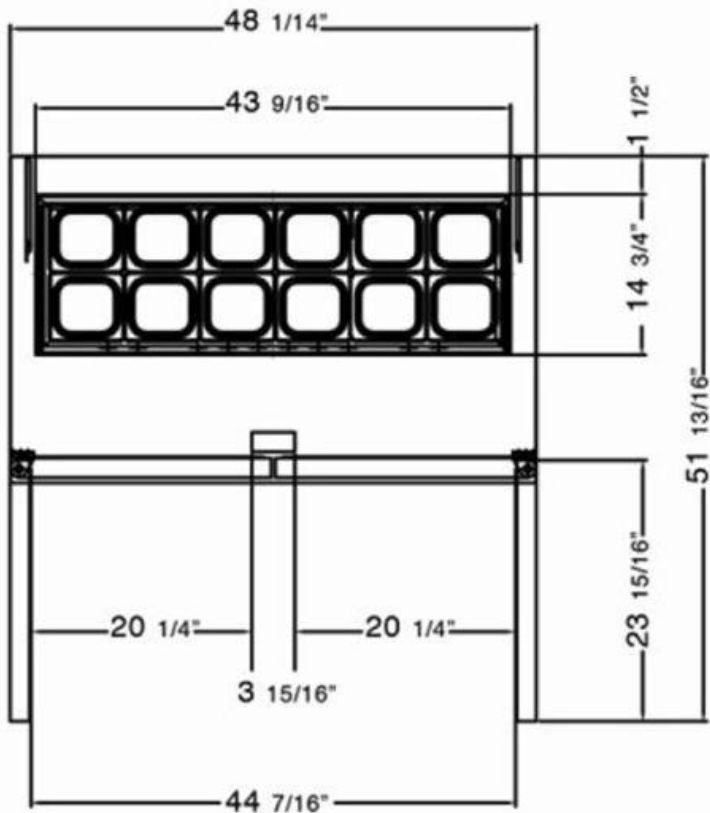
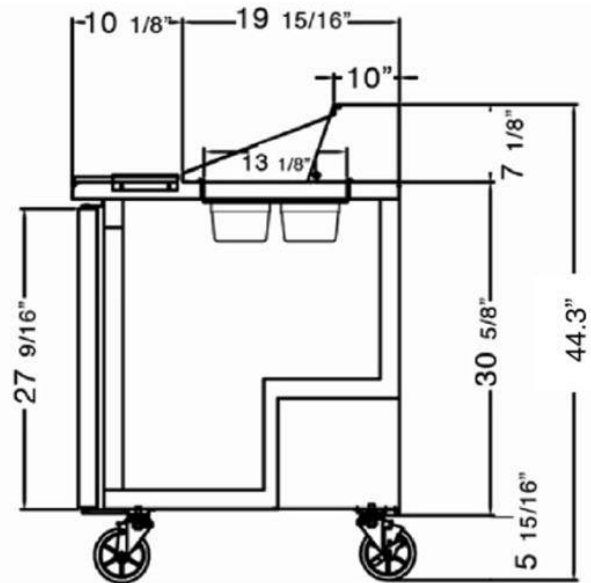
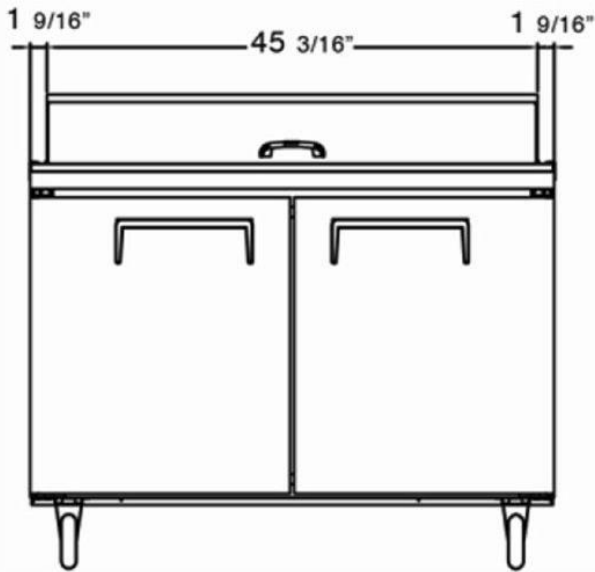

Elevate your kitchen efficiency with the Frigos Premium FGP-SL-2D—a 48.2" 2-Door Refrigerated Sandwich Prep Table. With a spacious 12 cubic feet capacity, optimal temperature control, and a sleek design, this prep table ensures easy ingredient access and freshness for peak performance in restaurants, delis, and catering businesses.

Warning: This product can expose you to chemicals including lead, which are known to the State of California to cause cancer, birth defects, or other reproductive harm. For more information, go to www.p65warnings.ca.gov.