

FRIGOS



Frigos Premium Solid Hinged Door Refrigerated Sandwich Prep Table SKU: FGP-SL-1D

- ★ 6.5 cu. ft. interior space
- ★ Equipped with 1 shelf and 1/4 HP compressor
- ★ Stainless steel exterior and interior
- ★ Durable door with recessed handle
- ★ 6" casters for easy mobility
- ★ Digital controller provides temperature readouts
- ★ Temperature holding range: 33°F to 41°F
- ★ Eco-friendly R290 refrigerant, 2.6 KW/24hr consumption



Amps	3.3
Capacity (Cu Ft)	6.5
Caster Size (Inch)	6
Color	Silver
Compressor Location	Back Mounted
Door Style	Swing
Door Type	Solid
Horsepower (HP)	1/4
KW per 24h	2.6
Number of Doors	1
Number of Shelves	1
Plug Type	Nema 5-15P
Refrigerant	R-290
Shipping Weight (lbs)	193
Temperature Range	33°F to 41°F
Voltage	115/60/1
Weight (lbs)	185

Introducing the Frigos Premium FGP-SL-1D, a compact yet highly efficient 27.5" Solid Hinged Door Refrigerated Sandwich Prep Table designed to elevate your sandwich and salad preparation in smaller kitchen spaces. With a 6.5 cubic feet capacity, this prep table offers both refrigerated storage and a dedicated workspace, ensuring your ingredients stay fresh and readily accessible.

The FGP-SL-1D boasts a back-mounted compressor, a solid swing door, and a single shelf for easy access and organization of your ingredients. It maintains a temperature range of 33°F to 41°F, ensuring your ingredients are stored at the ideal temperature for peak freshness. With a 1/4 HP compressor and eco-friendly R290 refrigerant, this prep table is designed for energy efficiency, consuming only 2.6 KW per 24 hours, reducing operational costs.

Featuring a sleek silver exterior, robust 6-inch caster wheels for effortless mobility, and a durable stainless steel interior and exterior, this prep table combines style and durability in one. Whether you run a compact cafe, a bustling deli, or any kitchen where space is at a premium, the Frigos Premium FGP-SL-1D is your dependable choice for efficient ingredient storage and sandwich/salad preparation, ensuring your kitchen operates at peak performance.

Item	Width (Inch)	Depth (Inch)	Height (Inch)	Material
Exterior	27.5	30	43.7	Stainless steel
Interior	23.9	23.6	26.7	Stainless steel



Kitchen Pro Restaurant Equipment: info@gokpe.com | www.kitchenproequipment.com | T. 1(800)603-0033

Note: Specifications subject to change without notice.

Plan View

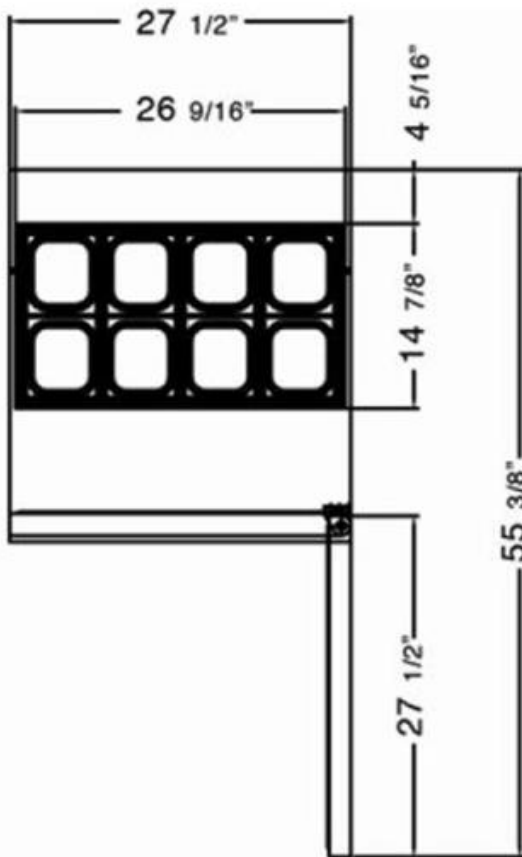
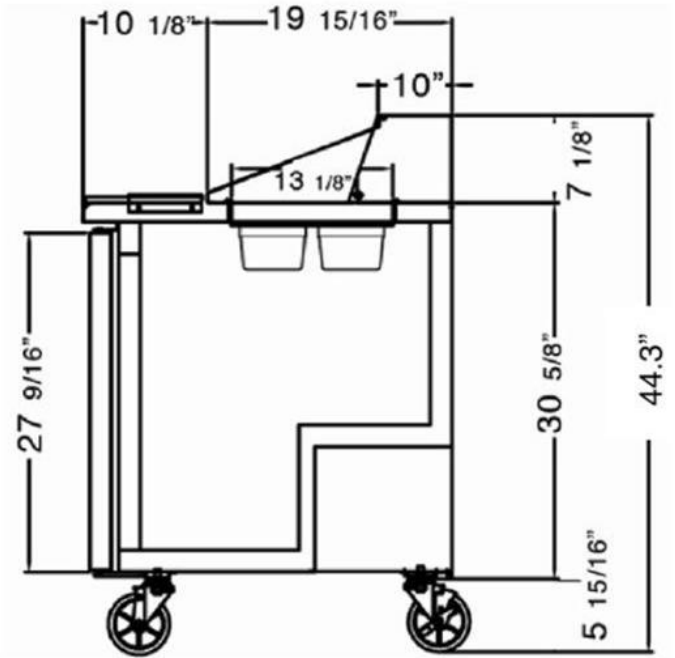
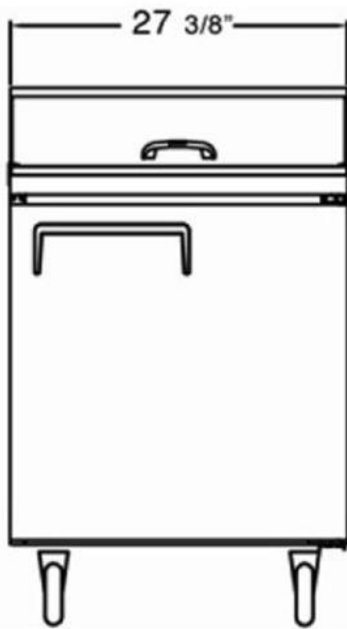

Upgrade your compact kitchen with the Frigos Premium FGP-SL-1D—a 27.5" Refrigerated Sandwich Prep Table. Efficiently designed for small spaces, it combines freshness and accessibility with a sleek, durable build, ensuring optimal performance in your kitchen. Choose Frigos Premium for a smart solution that maximizes efficiency without sacrificing quality.

Warning: This product can expose you to chemicals including lead, which are known to the State of California to cause cancer, birth defects, or other reproductive harm. For more information, go to www.p65warnings.ca.gov.