

FRIGOS



Frigos Premium Reach-In Freezer
Double Solid Door
SKU: FGP-FZ-2DBC/40

- ★ 35 cu. ft. interior space
- ★ Equipped with 6 shelves and 3/4 HP compressor
- ★ Stainless steel exterior and interior
- ★ Durable door with recessed handle
- ★ 4" casters for easy mobility
- ★ Digital controller provides temperature readouts
- ★ Temperature holding range: - 10°F to 0°F
- ★ Eco-friendly R290 refrigerant, 7.52 KW/24hr consumption



Amps	8.6
Capacity (Cu Ft)	35
Caster Size (Inch)	4
Color	Silver
Compressor Location	Bottom Mounted
Door Style	Swing
Door Type	Solid
Horsepower (HP)	3/4
KW per 24h	7.52
Number of Doors	2
Number of Shelves	6
Plug Type	Nema 5-15P
Refrigerant	R-290
Shipping Weight (lbs)	375
Temperature Range	-10° F- 0° F
Voltage	115/60/1
Weight (lbs)	331

Introducing the Frigos Premium FGP-FZ-2DBC/40, a top-notch 2-door bottom-mounted double solid door reach-in freezer with a spacious 35 cubic feet of storage capacity. Designed for professional kitchens, this freezer offers the perfect combination of functionality and efficiency, ensuring your frozen goods are preserved in ideal conditions.

The bottom-mounted compressor location enhances performance while making maintenance hassle-free, ensuring that this freezer runs smoothly. It utilizes the eco-friendly R-290 refrigerant, contributing to sustainability. The temperature range spans from -10°F to 0°F, enabling you to store a wide variety of frozen products safely, from raw ingredients to finished dishes.

Constructed with durable stainless steel, both on the interior and exterior, this freezer is built to last. Six sturdy shelves provide ample storage space and organization options for your frozen inventory. The silver finish adds a touch of sophistication to your kitchen, embodying the reliability and efficiency that the Frigos Premium FGP-FZ-2DBC/40 brings to your culinary establishment. If you need a top-quality double door reach-in freezer with a large capacity, this model is an excellent choice.

Item	Width (Inch)	Depth (Inch)	Height (Inch)	Material
Exterior	39.5	31.5	83.2	Stainless steel
Interior	35	25.2	60	Stainless steel



Kitchen Pro Restaurant Equipment: info@gokpe.com | www.kitchenproequipment.com | T. 1(800)603-0033

Note: Specifications subject to change without notice.

Plan View

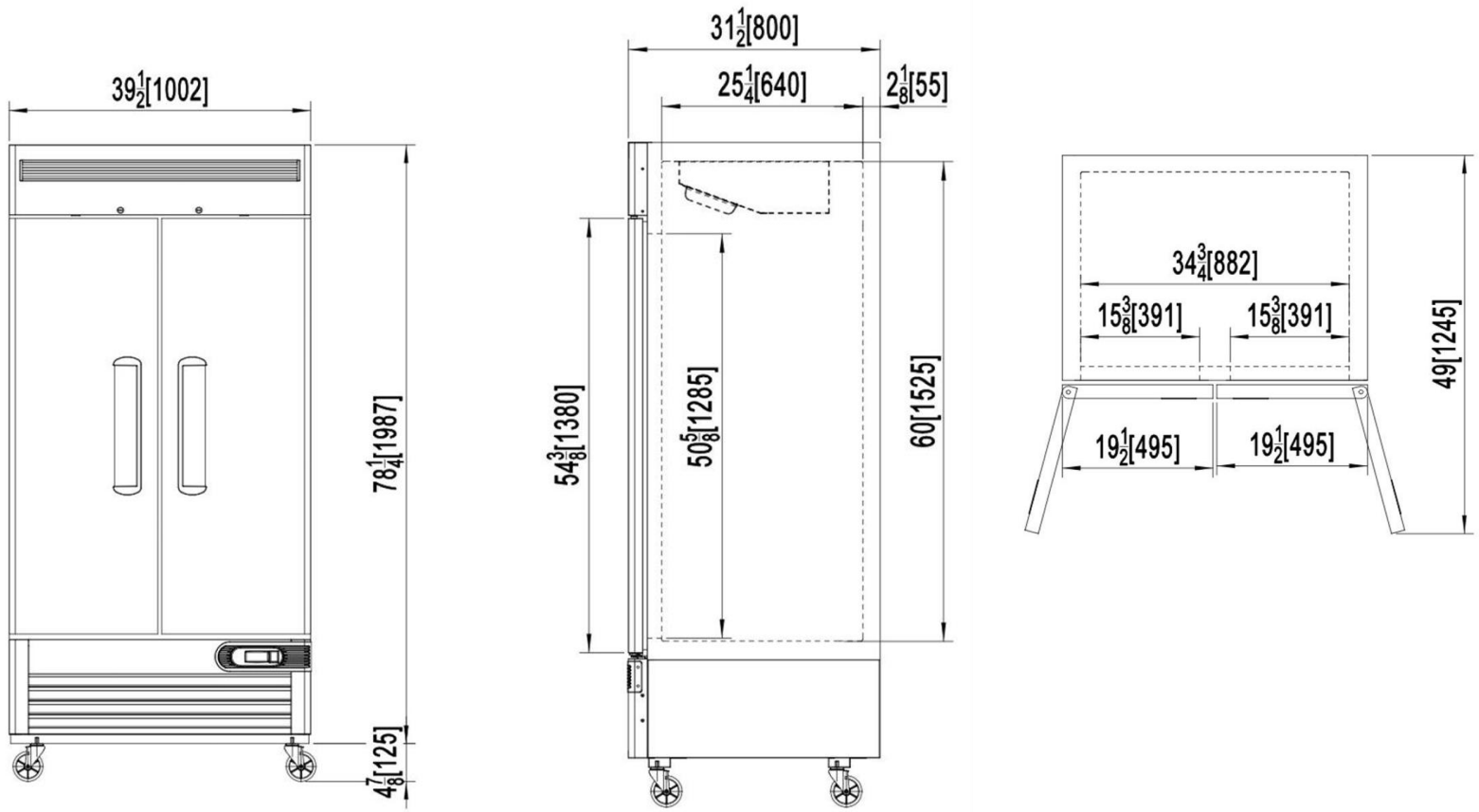

Upgrade your kitchen's frozen storage capabilities with the Frigos Premium FGP-FZ-2DBC/40, a cutting-edge solution that seamlessly blends capacity and efficiency. Designed for professional kitchens, this freezer not only ensures optimal preservation of your frozen goods but also prioritizes sustainability, making it the perfect choice for establishments that demand both performance and environmental responsibility.

Warning: This product can expose you to chemicals including lead, which are known to the State of California to cause cancer, birth defects, or other reproductive harm. For more information, go to www.p65warnings.ca.gov.