

# FRIGOS



## Frigos Premium 2 Drawer Refrigerated Chef Base SKU: FGP-CB-5260

- ★ 10.4 cu. ft. interior capacity for ample storage space
- ★ Accommodates up to 18 sixth-size food pans
- ★ Heavy-duty top holding a maximum of 717 lbs.
- ★ Preinstalled 6-inch casters for easy mobility
- ★ All stainless steel interior and exterior
- ★ Digital temperature controller and display
- ★ Temperature range: 33°F to 41°F
- ★ User-friendly digital temperature controller



<b>Amps</b>	2.3
<b>Capacity (Cu Ft)</b>	10.4
<b>Caster Size (Inch)</b>	6
<b>Certifications</b>	ETL Listed, ETL Sanitation
<b>Color</b>	Silver
<b>Compressor Location</b>	Right Side Mounted
<b>Door Type</b>	Solid
<b>Horsepower (HP)</b>	1/6
<b>KW per 24h</b>	1.87
<b>Number of Drawers</b>	2
<b>Plug Type</b>	Nema 5-15P
<b>Refrigerant</b>	R-134a
<b>Shipping Weight (lbs)</b>	556
<b>Temperature Range</b>	33°F to 41°F
<b>Voltage</b>	115/60/1
<b>Weight (lbs)</b>	478

Introducing the Frigos Premium FGP-CB-5260, a 52" 2 Drawer Refrigerated Chef Base with a 60" Extended Top, designed to enhance your kitchen's efficiency and organization. With a spacious 10.4 cu ft capacity, this chef base ensures your essential ingredients are stored at the optimal temperature range of 33°F to 41°F. The solid door design and 60" extended top provide ample workspace for food preparation and ingredient storage, making it the perfect addition to any bustling kitchen.

Crafted with precision, the Frigos Premium FGP-CB-5260 features two generous drawers and a sleek stainless steel exterior, combining functionality and style seamlessly. The 1/6 HP compressor, conveniently located on the right side, guarantees dependable cooling performance. It holds ETL Listed and ETL Sanitation certifications, meeting the highest quality and hygiene standards for your kitchen. With 6-inch casters for easy mobility, you can keep your workspace organized and efficient. Elevate your culinary experience with the Frigos Premium FGP-CB-5260 and have all your ingredients within reach in a clean and stylish kitchen environment, ensuring efficiency and convenience in your daily cooking endeavors.

Item	Width (Inch)	Depth (Inch)	Height (Inch)	Material
Exterior	60.5	32	26.6	Stainless steel
Interior	40	25.6	16.7	Stainless steel



**Kitchen Pro Restaurant Equipment:** [info@gokpe.com](mailto:info@gokpe.com) | [www.kitchenproequipment.com](http://www.kitchenproequipment.com) | T. 1(800)603-0033

Note: Specifications subject to change without notice.

# Plan View

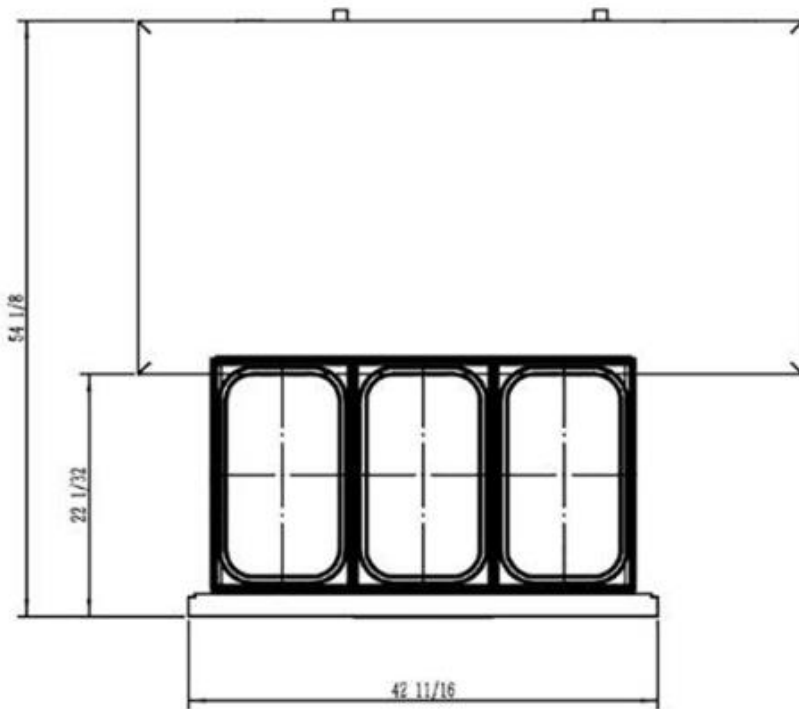
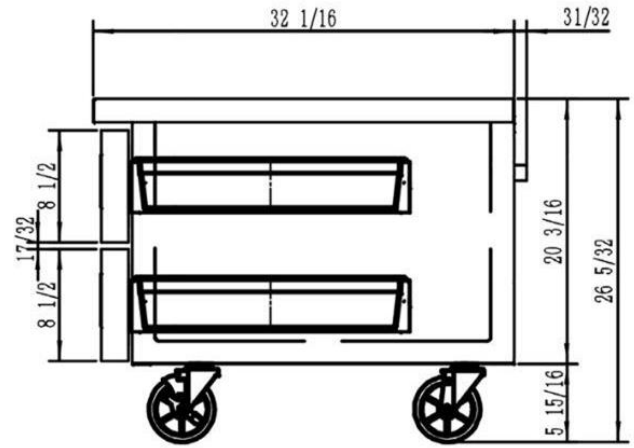
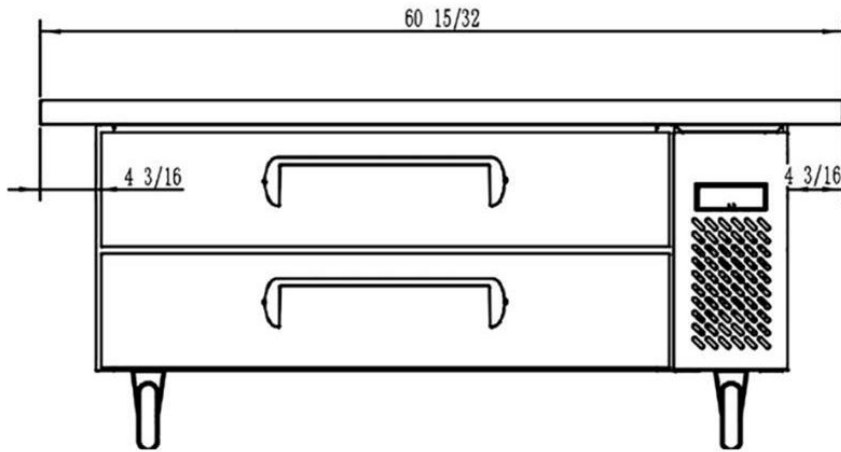

Elevate your kitchen with the Frigos Premium FGP-CB-5260 Chef Base. Offering optimal ingredient storage, ample workspace, and a sleek design, it combines functionality and style. Crafted with precision, featuring two drawers, a stainless steel exterior, and a 1/6 HP compressor for dependable cooling. ETL Listed and ETL Sanitation certifications ensure quality and hygiene. With 6-inch casters for mobility, this chef base enhances your culinary experience with efficiency and convenience.

**Warning:** This product can expose you to chemicals including lead, which are known to the State of California to cause cancer, birth defects, or other reproductive harm. For more information, go to [www.p65warnings.ca.gov](http://www.p65warnings.ca.gov).