

FRIGOS



Frigos Premium 2 Drawer Refrigerated Chef Base SKU: FGP-CB-48

- ★ 9.4 cu.ft. interior capacity offers generous storage space
- ★ Accommodates 15 sixth-size food pans
- ★ Top weight limit: 717 lbs. for versatile use
- ★ 2 drawers with recessed handles for easy access
- ★ Self-close drawers for added convenience
- ★ 4 total casters, 2 with locks, for mobility and stability
- ★ All stainless steel interior and exterior
- ★ Digital temperature controller



Amps	2.3
Capacity (Cu Ft)	9.4
Caster Size (Inch)	6
Certifications	ETL Listed, ETL Sanitation
Color	Silver
Compressor Location	Right Side Mounted
Door Type	Solid
Horsepower (HP)	1/6
KW per 24h	1.87
Number of Drawers	2
Plug Type	Nema 5-15P
Refrigerant	R-134a
Shipping Weight (lbs)	472
Temperature Range	33°F to 41°F
Voltage	115/60/1
Weight (lbs)	430

Introducing the Frigos Premium FGP-CB-48 48.4" 2 Drawer Refrigerated Chef Base, the ultimate companion for culinary enthusiasts and professional chefs alike. With a generous 9.4 cu ft capacity, this chef base provides a convenient and efficient storage solution for all your essential kitchen ingredients. Its solid door design maintains a precise temperature range of 33°F to 41°F, ensuring that your ingredients stay fresh and ready for your culinary creations.

Crafted with the highest standards in mind, the Frigos Premium FGP-CB-48 features two spacious drawers and a sleek stainless steel exterior, combining practicality and elegance. The 1/6 HP compressor, conveniently located on the right side, delivers reliable cooling performance. ETL Listed and ETL Sanitation certifications guarantee the utmost quality and hygiene standards, making it a trusted addition to any kitchen. The 6-inch casters provide easy mobility, allowing you to keep your workspace organized and efficient. Elevate your culinary experience with the Frigos Premium FGP-CB-48 and have all your ingredients within reach while enjoying a clean and stylish kitchen space.

Item	Width (Inch)	Depth (Inch)	Height (Inch)	Material
Exterior	48.4	32	26.6	Stainless steel
Interior	36.2	25.6	16.7	Stainless steel



Kitchen Pro Restaurant Equipment: info@gokpe.com | www.kitchenproequipment.com | T. 1(800)603-0033

Note: Specifications subject to change without notice.

Plan View

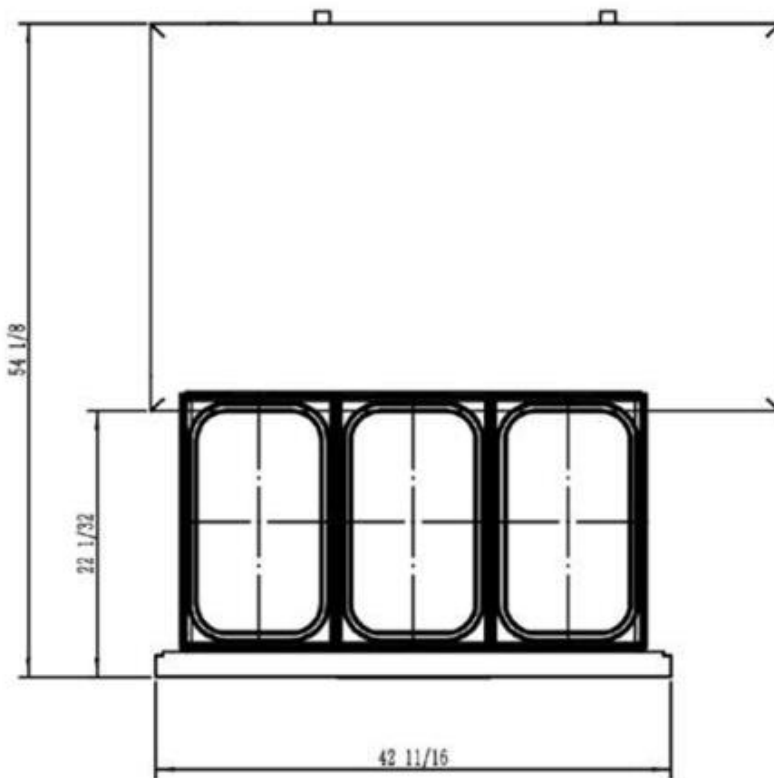
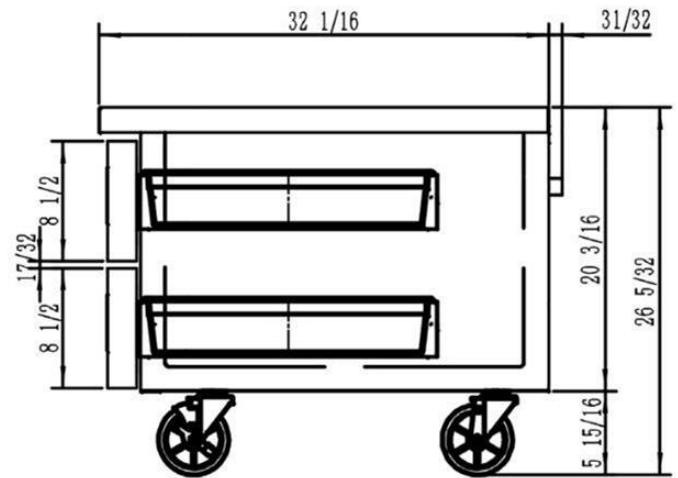
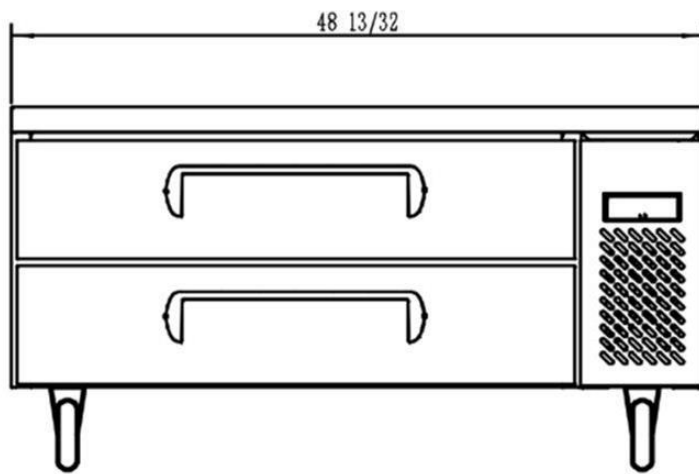

Upgrade your kitchen with the Frigos Premium FGP-CB-48 Chef Base. With a generous capacity, precise temperature control, and sleek stainless steel design, it ensures freshness and accessibility for your ingredients.

The 1/6 HP compressor guarantees reliable cooling, and ETL certifications ensure quality and hygiene. With 6-inch casters for mobility, this chef base creates a clean and stylish kitchen space for culinary enthusiasts and chefs alike.

Warning: This product can expose you to chemicals including lead, which are known to the State of California to cause cancer, birth defects, or other reproductive harm. For more information, go to www.p65warnings.ca.gov.