



## Frigos 1 Door Undercounter Refrigerator

SKU: FG-UCRF-29

- ★ Spacious: 6.7 cu ft capacity
- ★ Durable: Stainless steel exterior, painted aluminum interior
- ★ Efficient: Low energy usage (1.097 kW/24h)
- ★ Convenient: Self-closing doors, efficient LED lighting
- ★ Certified: ETL Electrical, ETL Sanitation, DOE
- ★ Mobility: Locking casters
- ★ Powerful: 1/6 HP compressor
- ★ Sleek: Silver finish, swing-style solid doors



Refrigerant	R290
Horsepower (HP)	1/6
Voltage (V)	115
KW per 24h	1.097
Wattage (W) (W)	327
Weight (lbs)	66
Shipping Weight (lbs)	74
Door Self Closed	Yes
Interior Material	Painted Aluminum
Exterior Material	Stainless Steel
Color	Silver
Door Style	Swing
Door Type	Solid
Number of Doors	1
Compressor Location	Back Mounted
Plug Type	NEMA 5-15P
Casters	Included
Caster Size (inch)	5

Introducing our top-of-the-line one-door commercial undercounter refrigerator, model FG-UCRF-29, built to deliver exceptional performance and reliability for your commercial kitchen. This undercounter refrigerator offers a spacious interior, with precise measurements of 29 inches in width, 30 3/8 inches in depth, and 38 3/8 inches in height, providing ample storage with a capacity of 6.7 cubic feet, designed to accommodate all your refrigerated items.

Made with a strong stainless steel exterior and a clean, easy-to-maintain painted aluminum interior, this unit combines durability with a clean and hygienic look. The thick 2-inch insulation, using Cyclopentane, ensures excellent temperature control, keeping your products fresh.

Item	Width (Inch)	Depth (Inch)	Height (Inch)
Exterior	29	30 3/8	38 3/8
Interior	31	35 1/4	40

Capacity (Cu Ft)	Number of Shelves	Shelf Capacity (lbs)
6.7	1	85

- Crafted with a robust stainless steel exterior, a pristine painted aluminum interior, and a dependable 304 stainless steel floor.
- Spacious Storage: Equipped with one epoxy-coated shelf, capable of supporting up to 85 pounds.
- Exceptional Insulation: Boasts substantial 2-inch insulation for superior temperature control.
- Highly Powerful: Driven by a precise 1/6 HP compressor for top-notch performance and reliability.



Kitchen Pro Restaurant Equipment: [info@gokpe.com](mailto:info@gokpe.com) | [www.kitchenproequipment.com](http://www.kitchenproequipment.com) | T. 1-800-603-0033

Note: Specifications subject to change without notice.

Equipped with a sturdy shelf that can hold up to 85 pounds, you'll have plenty of space for your ingredients and items. The built-in LED lighting ensures you can see everything clearly inside.

This commercial undercounter fridge is energy-efficient, using eco-friendly R290 refrigerant and powered by a 1/6 horsepower compressor operating at 115V/60Hz. This means it consumes very little energy, costing only 1.097 kW.h/24h, saving you money in the long run.

Hinge Location	Amps (A)	Hertz (Hz)	Temperature Range
Right	2.5	60	33°F to 40°F

The Frigos brand is known for quality, and this commercial under the counter refrigerator lives up to that reputation. Whether you're in the foodservice industry or running a commercial kitchen, you can trust this unit to keep your products at the right temperature, preserving their quality.

### **1 Door Undercounter Refrigerator SKU: FG-UCRF-29**

The self-closing door adds convenience and saves energy by ensuring it's always properly sealed. It's easy to move around with four 5-inch casters that provide stability.



Invest in the future of your business with our FG-UCRF-29 one-door undercounter refrigerator, perfect for your refrigeration needs. It's a powerful, energy-efficient, and reliable addition to any kitchen, designed to meet your needs for years to come. And don't forget to explore our selection of commercial undercounter refrigerators and other equipment to streamline your kitchen operations.

## Technical Data:

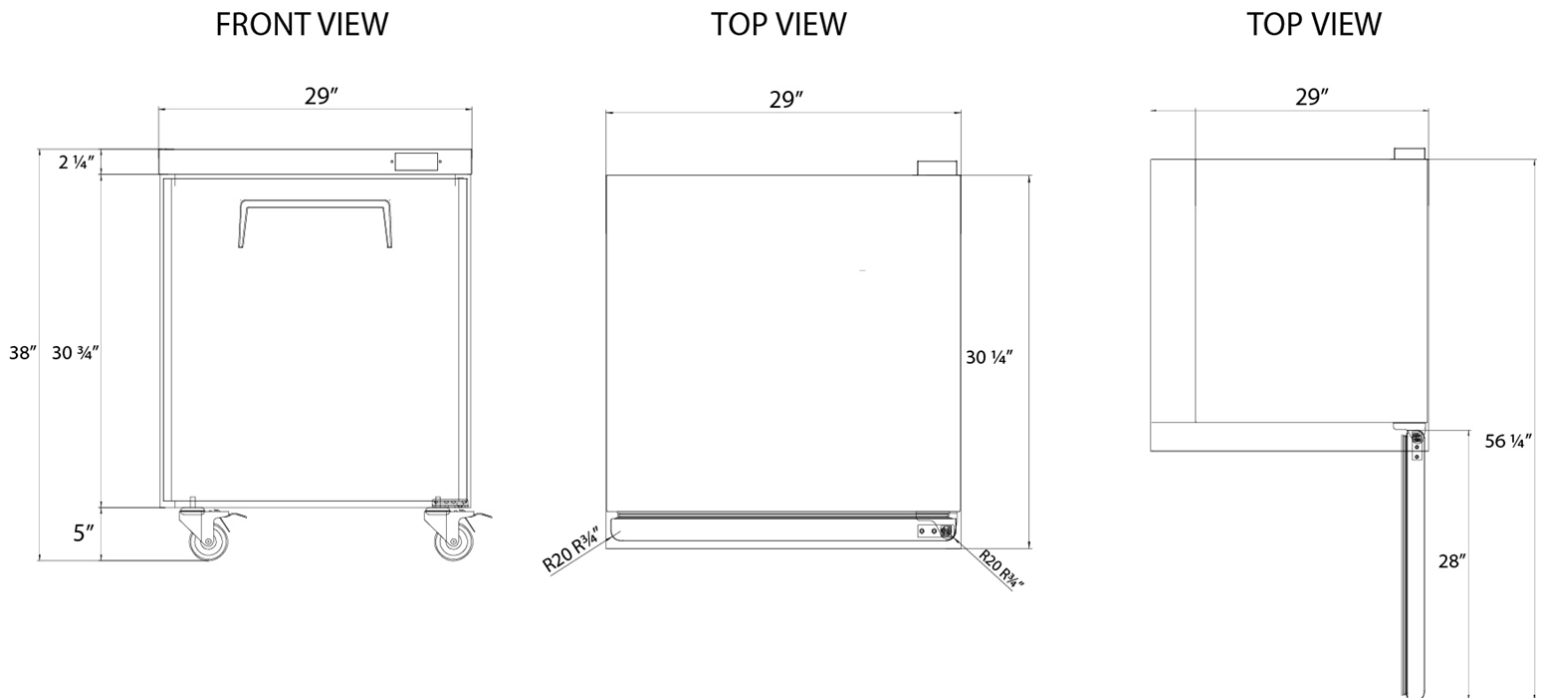

### 1 Door Undercounter Refrigerator SKU: FG-UCRF-29

Our FG-UCRF-29 under the counter commercial refrigerator is certified by ETL Electrical, ETL Sanitation, and DOE, meeting essential health and safety standards. Its stylish silver finish and swing-style solid door not only look professional but also offer easy access to your refrigerated items.



**Warning:** This product can expose you to chemicals including lead, which are known to the State of California to cause cancer, birth defects, or other reproductive harm. For more information, go to [www.p65warnings.ca.gov](http://www.p65warnings.ca.gov).