



Frigos 1 Door Undercounter Freezer

SKU: FG-UCFZ-29

- ★ Spacious: 6.7 cu ft capacity
- ★ Durable: Stainless steel exterior, painted aluminum interior
- ★ Efficient: Low energy usage (2.353 kW/24h)
- ★ Convenient: Self-closing doors, efficient LED lighting
- ★ Certified: ETL Electrical, ETL Sanitation, DOE
- ★ Mobility: Locking casters
- ★ Powerful: 1/6 HP compressor
- ★ Sleek: Silver finish, swing-style solid doors



Refrigerant	R290
Horsepower (HP)	1/6
Voltage (V)	115
KW per 24h	2.353
Wattage (W) (W)	327
Weight (lbs)	70
Shipping Weight (lbs)	78
Door Self Closed	Yes
Interior Material	Painted Aluminum
Exterior Material	Stainless Steel
Color	Silver
Door Style	Swing
Door Type	Solid
Number of Doors	1
Compressor Location	Back Mounted
Plug Type	NEMA 5-15P
Casters	Included
Caster Size (inch)	5

Introducing our top-of-the-line one-door commercial undercounter freezer, model FG-UCFZ-29, designed to provide outstanding performance and reliability for your commercial kitchen. This undercounter freezer offers a spacious interior, with precise measurements of 29 inches in width, 30 3/8 inches in depth, and 38 3/8 inches in height, delivering ample storage with a capacity of 6.7 cubic feet, perfect for accommodating all your frozen items.

Constructed with a robust stainless steel exterior, a pristine painted aluminum interior, and a reliable 304 stainless steel floor, this unit combines durability with a clean and hygienic appearance. The substantial 2-inch insulation, using Cyclopentane, ensures excellent temperature control, preserving the freshness of your products.

Item	Width (Inch)	Depth (Inch)	Height (Inch)
Exterior	29	30 3/8	38 3/8
Interior	31	35 1/4	40

Capacity (Cu Ft)	Number of Shelves	Shelf Capacity (lbs)
6.7	1	85

- Crafted with a robust stainless steel exterior, a pristine painted aluminum interior, and a dependable 304 stainless steel floor.
- Spacious Storage: Equipped with one epoxy-coated shelf, capable of supporting up to 85 pounds.
- Exceptional Insulation: Boasts substantial 2-inch insulation for superior temperature control.
- Highly Powerful: Driven by a precise 1/6 HP compressor for top-notch performance and reliability.



Featuring a sturdy shelf capable of supporting up to 85 pounds, you'll have sufficient space for your frozen ingredients and items. The built-in LED lighting guarantees excellent visibility inside.

This commercial undercounter freezer is energy-efficient, utilizing eco-friendly R290 refrigerant and powered by a 1/6 horsepower compressor operating at 115V/60Hz. It boasts low energy consumption, costing only 2.353 kW.h/24h, providing cost savings over time.

Hinge Location	Amps (A)	Hertz (Hz)	Temperature Range
Right	2.5	60	33°F to 40°F

Frigos, a trusted brand for quality, stands behind this commercial undercounter freezer. Whether you're in the foodservice industry or managing a commercial kitchen, you can rely on this unit to maintain the ideal temperature for your frozen products, preserving their quality.

1 Door Undercounter Freezer SKU: FG-UCFZ-29

The self-closing door enhances convenience and energy efficiency by ensuring a secure seal at all times. Maneuvering is effortless with four 5-inch casters providing stability.



Invest in the future of your business with our FG-UCFZ-29 one-door undercounter freezer, perfectly suited for your freezing needs. It's a powerful, energy-efficient, and dependable addition to any kitchen, designed to meet your requirements for years to come. Explore our selection of undercounter freezers and other equipment to optimize your kitchen operations

Technical Data:

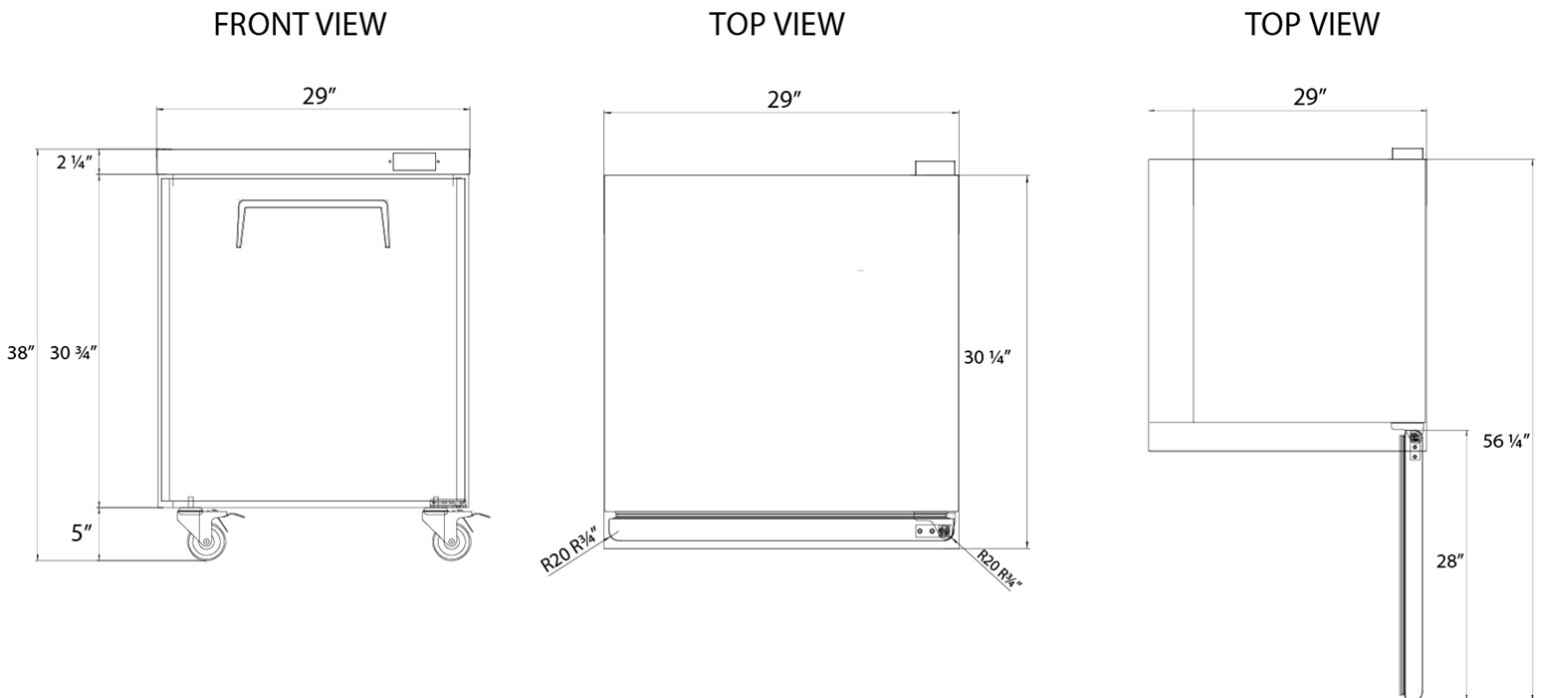

1 Door Undercounter Freezer SKU: FG-UCFZ-29

Our FG-UCFZ-29 undercounter freezer is certified by ETL Electrical, ETL Sanitation, and DOE, meeting essential health and safety standards. Its stylish silver finish and swing-style solid door not only offer a professional appearance but also provide easy access to your frozen items.



Warning: This product can expose you to chemicals including lead, which are known to the State of California to cause cancer, birth defects, or other reproductive harm. For more information, go to www.p65warnings.ca.gov.