



Frigos 2 Door Mega Top
Refrigerated Sandwich Prep Table
SKU: FG-SWPT-48-MT

- ★ Spacious: 13.8 cu ft capacity
- ★ Durable: Stainless steel exterior, painted aluminum interior
- ★ Efficient: Low energy usage (3.95 kW.h/24h)
- ★ Convenient: Self-closing doors, efficient LED lighting
- ★ Certified: ETL Electrical, ETL Sanitation, DOE
- ★ Mobility: Locking casters
- ★ Powerful: 1/5 HP compressor
- ★ Sleek: Silver finish, swing-style solid doors



Refrigerant	R290
Horsepower (HP)	1/5
Voltage (V)	115V/60hz
KW per 24h	3.95kw.h/24h
Wattage	443
Weight (lbs)	107
Shipping Weight (lbs)	126
Door Self Closed	Yes
Interior Material	Painted Aluminum
Exterior Material	Stainless Steel
Color	Silver
Door Style	Swing
Door Type	Solid
Number of Doors	2
Compressor Location	Rear Mounted
Shelf Capacity (lbs)	85
Plug Type	NEMA 5-15P

Introducing our premium two-door commercial sandwich salad prep table refrigerator, model FG-SWPT-48-MT, meticulously designed to deliver outstanding performance and reliability for your commercial kitchen. This prep table refrigerator offers a spacious interior with precise measurements of 48 3/8 inches in width, 37 1/4 inches in depth, and 47 7/8 inches in height, providing ample storage with a capacity of 13.8 cubic feet, designed to accommodate all your salad and sandwich ingredients.

Crafted with a robust stainless steel exterior and a clean, easy-to-maintain painted aluminum interior, this unit combines durability with a clean and hygienic appearance. The substantial 2-inch insulation, using Cyclopentane, ensures excellent temperature control, keeping your ingredients fresh.

Item	Width (Inch)	Depth (Inch)	Height (Inch)
Exterior	48 3/8	37 1/4	47 7/8
Interior	44 1/4	25 3/8	28 3/4

Capacity (Cu Ft)	Number of Shelves
13.8	2

- Crafted with a robust stainless steel exterior, a clean painted aluminum interior, and a dependable 304 stainless steel floor.
- Ample Storage: Includes 2 epoxy-coated shelves, capable of supporting up to 85 pounds.
- Superior Insulation: Features substantial 2-inch insulation for precise temperature control.
- High-Performance: Powered by a precise 1/5 HP compressor for top-tier reliability and efficiency.



Kitchen Pro Restaurant Equipment: info@gokpe.com | www.kitchenproequipment.com | T. 1-800-603-0033

Note: Specifications subject to change without notice.

Equipped with two sturdy shelves, each capable of holding up to 85 pounds, you'll have plenty of space for your salad and sandwich preparation items. The built-in LED lighting guarantees clear visibility of your ingredients, ensuring efficient food preparation.

This commercial sandwich salad prep table refrigerator is energy-efficient, utilizing eco-friendly R290 refrigerant and powered by a 1/5 horsepower compressor operating at 115V/60Hz. It consumes minimal energy, costing only 3.95 kW.h/24h, resulting in long-term cost savings.

Hinge Location	Amps	Hertz	Temperature Range
Left/Right	3.4A	60Hz	33°F - 40°F
Phase	Shelves Size	Shelf Capacity (lbs)	Caster Size (Inch)
1	20.8 x 19	85	5"

The Frigos brand is synonymous with quality, and this sandwich salad prep table refrigerator upholds that reputation. Whether you're in the foodservice industry or running a commercial kitchen, you can trust this unit to keep your salad and sandwich ingredients at the right temperature, preserving their quality.

2 Door Mega Top Refrigerated Sandwich Prep Table SKU: FG-SWPT-48-MT

The self-closing doors add convenience and save energy by ensuring a proper seal at all times. Moving it around is effortless with four 5-inch casters that provide stability and mobility.



Invest in the future of your business with our FG-SWPT-48-MT two-door mega top sandwich salad prep table refrigerator, perfect for your salad and sandwich preparation needs. It's a powerful, energy-efficient, and reliable addition to any kitchen, designed to meet your needs for years to come. Explore our selection of commercial sandwich salad prep tables and other equipment to optimize your kitchen operations. Elevate your kitchen with Frigos.

Technical Data:

FRONT VIEW

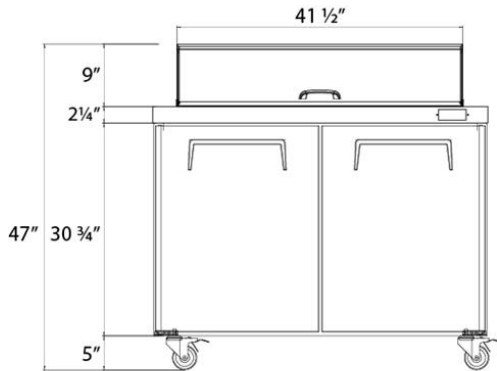

TOP VIEW

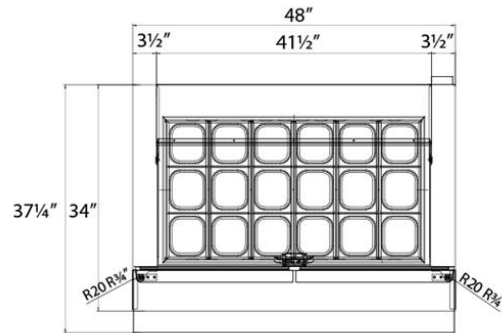

TOP VIEW

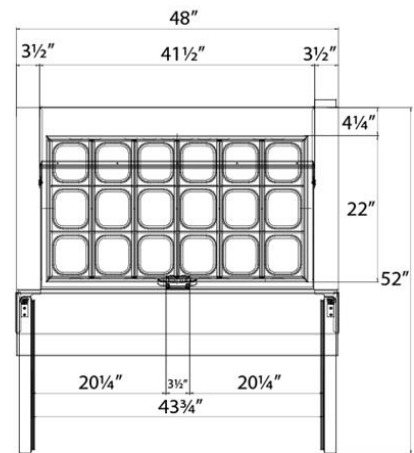

2 Door Mega Top Refrigerated Sandwich Prep Table SKU: FG-SWPT-48-MT

Our FG-SWPT-48-MT sandwich salad prep table refrigerator is certified by ETL Electrical, ETL Sanitation, and DOE, meeting essential health and safety standards. Its stylish silver finish and swing-style solid doors not only convey a professional appearance but also offer easy access to your ingredients.



Warning: This product can expose you to chemicals including lead, which are known to the State of California to cause cancer, birth defects, or other reproductive harm. For more information, go to www.p65warnings.ca.gov.